

**FINANCIAL ASSISTANCE
FUNDING OPPORTUNITY ANNOUNCEMENT**



**ADVANCED RESEARCH PROJECTS AGENCY – ENERGY (ARPA-E)
U.S. DEPARTMENT OF ENERGY**

***UNLOCKING LASTING TRANSFORMATIVE RESILIENCY ADVANCES BY FASTER
ACTUATION OF POWER SEMICONDUCTOR TECHNOLOGIES (ULTRAFAST)***

Announcement Type: **Initial Announcement Modification 01**
Funding Opportunity No. DE-FOA-0002998
CFDA Number 81.135

Funding Opportunity Announcement (FOA) Issue Date:	February 24, 2023
First Deadline for Questions to ARPA-E-CO@hq.doe.gov:	5 PM ET, March 18, 2023
Submission Deadline for Concept Papers:	9:30 AM ET, March 28, 2023
Second Deadline for Questions to ARPA-E-CO@hq.doe.gov:	5 PM ET, TBD June 2, 2023
Submission Deadline for Full Applications:	9:30 AM ET, TBD June 13, 2023
Submission Deadline for Replies to Reviewer Comments:	5 PM ET, TBD July 24, 2023
Expected Date for Selection Notifications:	August 2023
Total Amount to Be Awarded	Approximately \$48 million, subject to the availability of appropriated funds to be shared between FOAs DE-FOA-0002998 and DE-FOA-0002999.
Anticipated Awards	ARPA-E may issue one, multiple, or no awards under this FOA. The Federal share of awards may vary between \$250,000 and \$10 million.

- For eligibility criteria, see Section III.A of the FOA.
- For cost share requirements under this FOA, see Section III.B of the FOA.
- To apply to this FOA, Applicants must register with and submit application materials through ARPA-E eXCHANGE (<https://arpa-e-foa.energy.gov/Registration.aspx>). For detailed guidance on using ARPA-E eXCHANGE, see Section IV.H.1 of the FOA.
- Applicants are responsible for meeting each submission deadline. Applicants are strongly encouraged to submit their applications at least 48 hours in advance of the submission deadline.
- For detailed guidance on compliance and responsiveness criteria, see Sections III.C.1 through III.C.4 of the FOA.

Questions about this FOA? Check the Frequently Asked Questions available at <http://arpa-e.energy.gov/faq>. For questions that have not already been answered, email ARPA-E-CO@hq.doe.gov (with FOA name and number in subject line); see FOA Sec. VII.A. Problems with ARPA-E eXCHANGE? Email ExchangeHelp@hq.doe.gov (with FOA name and number in subject line).

MODIFICATIONS

All modifications to the Funding Opportunity Announcement (FOA) are highlighted in yellow in the body of the FOA.

Mod. No.	Date	Description of Modifications
01	MAY 11, 2023	<ul style="list-style-type: none"> • Inserted certain deadlines, including the deadlines for submitting questions and Full Applications, see Cover Page and Required Documents Checklist. • Revised the Required Documents Checklist and Sections IV.D, IV.E, and IV.G of the FOA to provide guidance on required application forms and the content and form of Full Applications and Replies to Reviewer Comments. Applicants are strongly encouraged to use the templates provided on ARPA-E eXCHANGE (https://arpa-e-foa.energy.gov). • Inserted criteria that ARPA-E will use to evaluate Full Applications, see Section V.A.2 of the FOA. • Inserted criteria that ARPA-E will use to evaluate Replies to Reviewer Comments in Section V.A.3 of the FOA. • Inserted information on the anticipated announcement and award dates, see Section V.C of the FOA. • Inserted information concerning Full Application Notifications, see Section VI.A.3 of the FOA. • Inserted Administrative and National Policy Requirements, see Section VI.B of the FOA. • Inserted Reporting Requirements, see Section VI.C of the FOA. • Inserted Export Control requirements, see Section VI.K of the FOA.

Questions about this FOA? Check the Frequently Asked Questions available at <http://arpa-e.energy.gov/faq>. For questions that have not already been answered, email ARPA-E-CO@hq.doe.gov (with FOA name and number in subject line); see FOA Sec. VII.A. Problems with ARPA-E eXCHANGE? Email ExchangeHelp@hq.doe.gov (with FOA name and number in subject line).

TABLE OF CONTENTS

REQUIRED DOCUMENTS CHECKLIST - 6 -

FUNDING OPPORTUNITY DESCRIPTION - 7 -

A. AGENCY OVERVIEW - 7 -

B. PROGRAM OVERVIEW - 8 -

1. SUMMARY - 8 -

2. BACKGROUND - 10 -

A) CURRENT APPROACH - 11 -

B) OTHER SIMILAR ACTIVITIES - 15 -

C. PROGRAM OBJECTIVES - 18 -

1. TECHNOLOGY DEVELOPMENT - 18 -

2. TECHNOLOGY-TO-MARKET (T2M) - 21 -

D. TECHNICAL CATEGORIES OF INTEREST - 22 -

E. TECHNICAL PERFORMANCE TARGETS - 24 -

I. AWARD INFORMATION - 29 -

A. AWARD OVERVIEW - 29 -

B. RENEWAL AWARDS - 29 -

C. ARPA-E FUNDING AGREEMENTS - 30 -

1. COOPERATIVE AGREEMENTS - 30 -

2. FUNDING AGREEMENTS WITH FFRDCs/DOE LABS, GOGOS, AND FEDERAL INSTRUMENTALITIES - 30 -

3. OTHER TRANSACTIONS AUTHORITY - 31 -

D. STATEMENT OF SUBSTANTIAL INVOLVEMENT - 31 -

II. ELIGIBILITY INFORMATION - 33 -

A. ELIGIBLE APPLICANTS - 33 -

1. INDIVIDUALS - 33 -

2. DOMESTIC ENTITIES - 33 -

3. FOREIGN ENTITIES - 33 -

4. CONSORTIUM ENTITIES - 34 -

B. COST SHARING - 34 -

1. BASE COST SHARE REQUIREMENT - 34 -

2. INCREASED COST SHARE REQUIREMENT - 35 -

3. REDUCED COST SHARE REQUIREMENT - 35 -

4. LEGAL RESPONSIBILITY - 36 -

5. COST SHARE ALLOCATION - 36 -

6. COST SHARE TYPES AND ALLOWABILITY - 36 -

7. COST SHARE CONTRIBUTIONS BY FFRDCs AND GOGOS - 37 -

8. COST SHARE VERIFICATION - 38 -

C. OTHER - 38 -

1. COMPLIANT CRITERIA - 38 -

2. RESPONSIVENESS CRITERIA - 39 -

3. SUBMISSIONS SPECIFICALLY NOT OF INTEREST - 40 -

4. LIMITATION ON NUMBER OF SUBMISSIONS - 40 -

Questions about this FOA? Check the Frequently Asked Questions available at <http://arpa-e.energy.gov/faq>. For questions that have not already been answered, email ARPA-E-CO@hq.doe.gov (with FOA name and number in subject line); see FOA Sec. VII.A. Problems with ARPA-E eXCHANGE? Email ExchangeHelp@hq.doe.gov (with FOA name and number in subject line).

III.	APPLICATION AND SUBMISSION INFORMATION	- 41 -
A.	APPLICATION PROCESS OVERVIEW	- 41 -
1.	REGISTRATION IN ARPA-E eXCHANGE.....	- 41 -
2.	CONCEPT PAPERS	- 41 -
3.	FULL APPLICATIONS	- 41 -
4.	REPLY TO REVIEWER COMMENTS	- 42 -
5.	PRE-SELECTION CLARIFICATIONS AND “DOWN-SELECT” PROCESS	- 42 -
6.	SELECTION FOR AWARD NEGOTIATIONS	- 42 -
B.	APPLICATION FORMS	- 43 -
C.	CONTENT AND FORM OF CONCEPT PAPERS.....	- 43 -
1.	CONCEPT PAPER.....	- 44 -
A.	CONCEPT SUMMARY.....	- 44 -
B.	INNOVATION AND IMPACT	- 44 -
C.	PROPOSED WORK	- 44 -
D.	TEAM ORGANIZATION AND CAPABILITIES	- 45 -
D.	CONTENT AND FORM OF FULL APPLICATIONS.....	- 45 -
1.	FIRST COMPONENT: TECHNICAL VOLUME.....	- 46 -
2.	SECOND COMPONENT: SF-424	- 46 -
3.	THIRD COMPONENT: BUDGET JUSTIFICATION WORKBOOK/SF-424A	- 47 -
4.	FOURTH COMPONENT: SUMMARY FOR PUBLIC RELEASE	- 48 -
5.	FIFTH COMPONENT: SUMMARY SLIDE.....	- 49 -
6.	SIXTH COMPONENT: BUSINESS ASSURANCES & DISCLOSURES FORM.....	- 50 -
E.	CONTENT AND FORM OF REPLIES TO REVIEWER COMMENTS	- 50 -
F.	INTERGOVERNMENTAL REVIEW	- 51 -
G.	FUNDING RESTRICTIONS.....	- 51 -
1.	ALLOWABLE COSTS.....	- 51 -
2.	PRE-AWARD COSTS.....	- 52 -
3.	PATENT COSTS.....	- 52 -
4.	CONSTRUCTION.....	- 52 -
5.	FOREIGN TRAVEL.....	- 52 -
6.	PERFORMANCE OF WORK IN THE UNITED STATES.....	- 53 -
7.	PURCHASE OF NEW EQUIPMENT	- 53 -
8.	TECHNOLOGY TRANSFER AND OUTREACH	- 53 -
9.	LOBBYING	- 54 -
10.	CONFERENCE SPENDING	- 54 -
11.	INDEPENDENT RESEARCH AND DEVELOPMENT COSTS.....	- 55 -
12.	PROHIBITION ON CERTAIN TELECOMMUNICATIONS AND VIDEO SURVEILLANCE SERVICES OR EQUIPMENT	- 55 -
13.	BUY AMERICA REQUIREMENT FOR PUBLIC INFRASTRUCTURE PROJECTS	- 56 -
14.	REQUIREMENT FOR FINANCIAL PERSONNEL.....	- 56 -
H.	OTHER SUBMISSION REQUIREMENTS.....	- 56 -
1.	USE OF ARPA-E eXCHANGE	- 56 -
IV.	APPLICATION REVIEW INFORMATION	- 58 -
A.	CRITERIA	- 58 -
12.	CRITERIA FOR CONCEPT PAPERS.....	- 58 -

Questions about this FOA? Check the Frequently Asked Questions available at <http://arpa-e.energy.gov/faq>. For questions that have not already been answered, email ARPA-E-CO@hq.doe.gov (with FOA name and number in subject line); see FOA Sec. VII.A. Problems with ARPA-E eXCHANGE? Email ExchangeHelp@hq.doe.gov (with FOA name and number in subject line).

13.	CRITERIA FOR FULL APPLICATIONS	- 59 -
14.	CRITERIA FOR REPLIES TO REVIEWER COMMENTS	- 60 -
B.	REVIEW AND SELECTION PROCESS	- 60 -
1.	PROGRAM POLICY FACTORS	- 60 -
2.	ARPA-E REVIEWERS	- 61 -
3.	ARPA-E SUPPORT CONTRACTOR	- 62 -
C.	ANTICIPATED ANNOUNCEMENT AND AWARD DATES	- 62 -
V.	AWARD ADMINISTRATION INFORMATION	- 63 -
A.	AWARD NOTICES	- 63 -
1.	REJECTED SUBMISSIONS	- 63 -
2.	CONCEPT PAPER NOTIFICATIONS	- 63 -
3.	FULL APPLICATION NOTIFICATIONS	- 63 -
B.	ADMINISTRATIVE AND NATIONAL POLICY REQUIREMENTS	- 64 -
1.	UNIQUE ENTITY IDENTIFIER AND SAM, FSRS, AND FEDCONNECT REGISTRATIONS	- 65 -
2.	NATIONAL POLICY ASSURANCES	- 66 -
3.	PROOF OF COST SHARE COMMITMENT AND ALLOWABILITY	- 66 -
4.	COST SHARE PAYMENTS	- 66 -
5.	ENVIRONMENTAL IMPACT QUESTIONNAIRE	- 66 -
6.	TECHNOLOGY-TO-MARKET PLAN	- 67 -
7.	INTELLECTUAL PROPERTY AND DATA MANAGEMENT PLANS	- 67 -
8.	U.S. COMPETITIVENESS	- 68 -
9.	CORPORATE FELONY CONVICTIONS AND FEDERAL TAX LIABILITY	- 69 -
10.	APPLICANT RISK ANALYSIS	- 69 -
11.	RECIPIENT INTEGRITY AND PERFORMANCE MATTERS	- 70 -
12.	NONDISCLOSURE AND CONFIDENTIALITY AGREEMENTS REPRESENTATIONS	- 70 -
13.	INTERIM CONFLICT OF INTEREST POLICY FOR FINANCIAL ASSISTANCE	- 71 -
14.	COMMERCIALIZATION PLAN AND SOFTWARE REPORTING	- 72 -
C.	REPORTING	- 72 -
VI.	AGENCY CONTACTS	- 73 -
A.	COMMUNICATIONS WITH ARPA-E	- 73 -
B.	DEBRIEFINGS	- 74 -
VII.	OTHER INFORMATION	- 75 -
A.	TITLE TO SUBJECT INVENTIONS	- 75 -
B.	GOVERNMENT RIGHTS IN SUBJECT INVENTIONS	- 75 -
1.	GOVERNMENT USE LICENSE	- 76 -
2.	MARCH-IN RIGHTS	- 76 -
C.	RIGHTS IN TECHNICAL DATA	- 76 -
D.	PROTECTED PERSONALLY IDENTIFIABLE INFORMATION	- 77 -
E.	FOAs AND FOA MODIFICATIONS	- 77 -
F.	OBLIGATION OF PUBLIC FUNDS	- 77 -
G.	REQUIREMENT FOR FULL AND COMPLETE DISCLOSURE	- 78 -
H.	RETENTION OF SUBMISSIONS	- 78 -
I.	MARKING OF CONFIDENTIAL INFORMATION	- 78 -

Questions about this FOA? Check the Frequently Asked Questions available at <http://arpa-e.energy.gov/faq>. For questions that have not already been answered, email ARPA-E-CO@hq.doe.gov (with FOA name and number in subject line); see FOA Sec. VII.A. Problems with ARPA-E eXCHANGE? Email ExchangeHelp@hq.doe.gov (with FOA name and number in subject line).

J. COMPLIANCE AUDIT REQUIREMENT - 79 -
K. EXPORT CONTROL - 79 -
VIII. GLOSSARY - 80 -

Questions about this FOA? Check the Frequently Asked Questions available at <http://arpa-e.energy.gov/faq>. For questions that have not already been answered, email ARPA-E-CO@hq.doe.gov (with FOA name and number in subject line); see FOA Sec. VII.A. Problems with ARPA-E eXCHANGE? Email ExchangeHelp@hq.doe.gov (with FOA name and number in subject line).

REQUIRED DOCUMENTS CHECKLIST

For an overview of the application process, see Section IV.A of the FOA.

For guidance regarding requisite application forms, see Section IV.B of the FOA.

For guidance regarding the content and form of Concept Papers, Full Applications, and Replies to Reviewer Comments, see Sections IV.C, IV.D, and IV.E of the FOA.

SUBMISSION	COMPONENTS	OPTIONAL/ MANDATORY	FOA SECTION	DEADLINE
Concept Paper	<ul style="list-style-type: none"> • Each Applicant must submit a Concept Paper in Adobe PDF format by the stated deadline. The Concept Paper must not exceed 4 pages in length including graphics, figures, and/or tables, and must include the following: <ul style="list-style-type: none"> ○ Concept Summary ○ Innovation and Impact ○ Proposed Work ○ Team Organization and Capabilities 	Mandatory	IV.C	9:30 AM ET, March 28, 2023
Full Application	<ul style="list-style-type: none"> • Each Applicant must submit a Technical Volume in Adobe PDF format by the stated deadline. The Technical Volume must include the following: <ul style="list-style-type: none"> ○ Executive Summary (1 page max.) ○ Sections 1-5 (20 pages max.) <ul style="list-style-type: none"> • 1. Innovation and Impact • 2. Proposed Work • 3. Team Organization and Capabilities • 4. Technology to Market • 5. Budget ○ Bibliographic References (no page limit) ○ Personal Qualification Summaries (each Personal Qualification Summary limited to 3 pages in length, no cumulative page limit) • The Technical Volume must be accompanied by: <ul style="list-style-type: none"> ○ SF-424 (no page limit, Adobe PDF format); ○ Budget Justification Workbook/SF424A (no page limit, Microsoft Excel format); ○ Summary for Public Release (250 words max., Adobe PDF format); ○ Summary Slide (1 page limit, Microsoft PowerPoint format); and ○ Completed and signed Business Assurances & Disclosures Form (no page limit, Adobe PDF format). 	Mandatory	IV.D	9:30 AM ET, TBD June 13, 2023
Reply to Reviewer Comments	<ul style="list-style-type: none"> • Each Applicant may submit a Reply to Reviewer Comments in Adobe PDF format. This submission is optional. The Reply may include: <ul style="list-style-type: none"> ○ Up to 2 pages of text; and ○ Up to 1 page of images. 	Optional	IV.E	5 PM ET, TBD July 24, 2023

Questions about this FOA? Check the Frequently Asked Questions available at <http://arpa-e.energy.gov/faq>. For questions that have not already been answered, email ARPA-E-CO@hq.doe.gov (with FOA name and number in subject line); see FOA Sec. VII.A. Problems with ARPA-E eXCHANGE? Email ExchangeHelp@hq.doe.gov (with FOA name and number in subject line).

FUNDING OPPORTUNITY DESCRIPTION

A. AGENCY OVERVIEW

The Advanced Research Projects Agency – Energy (ARPA-E), an organization within the Department of Energy (DOE), is chartered by Congress in the America COMPETES Act of 2007 (P.L. 110-69), as amended by the America COMPETES Reauthorization Act of 2010 (P.L. 111-358), as further amended by the Energy Act of 2020 (P.L. 116-260):

- “(A) to enhance the economic and energy security of the United States through the development of energy technologies that—
- (i) reduce imports of energy from foreign sources;
 - (ii) reduce energy-related emissions, including greenhouse gases;
 - (iii) improve the energy efficiency of all economic sectors;
 - (iv) provide transformative solutions to improve the management, clean-up, and disposal of radioactive waste and spent nuclear fuel; and
 - (v) improve the resilience, reliability, and security of infrastructure to produce, deliver, and store energy; and
- (B) to ensure that the United States maintains a technological lead in developing and deploying advanced energy technologies.”

ARPA-E issues this Funding Opportunity Announcement (FOA) under its authorizing statute codified at 42 U.S.C. § 16538. The FOA and any cooperative agreements or grants made under this FOA are subject to 2 C.F.R. Part 200 as supplemented by 2 C.F.R. Part 910.

ARPA-E funds research on, and the development of, transformative science and technology solutions to address the energy and environmental missions of the Department. The agency focuses on technologies that can be meaningfully advanced with a modest investment over a defined period of time in order to catalyze the translation from scientific discovery to early-stage technology. For the latest news and information about ARPA-E, its programs and the research projects currently supported, see: <http://arpa-e.energy.gov/>.

ARPA-E funds transformational research. Existing energy technologies generally progress on established “learning curves” where refinements to a technology and the economies of scale that accrue as manufacturing and distribution develop drive improvements to the cost/performance metric in a gradual fashion. This continual improvement of a technology is important to its increased commercial deployment and is appropriately the focus of the private sector or the applied technology offices within DOE. By contrast, ARPA-E supports transformative research that has the potential to create fundamentally new learning curves. ARPA-E technology projects typically start with cost/performance estimates well above the level of an incumbent technology. Given the high risk inherent in these projects, many will fail to progress, but some may succeed in generating a new learning curve with a projected cost/performance metric that is significantly better than that of the incumbent technology.

Questions about this FOA? Check the Frequently Asked Questions available at <http://arpa-e.energy.gov/faq>. For questions that have not already been answered, email ARPA-E-CO@hq.doe.gov (with FOA name and number in subject line); see FOA Sec. VII.A. Problems with ARPA-E eXCHANGE? Email ExchangeHelp@hq.doe.gov (with FOA name and number in subject line).

ARPA-E funds technology with the potential to be disruptive in the marketplace. The mere creation of a new learning curve does not ensure market penetration. Rather, the ultimate value of a technology is determined by the marketplace, and impactful technologies ultimately become disruptive – that is, they are widely adopted and displace existing technologies from the marketplace or create entirely new markets. ARPA-E understands that definitive proof of market disruption takes time, particularly for energy technologies. Therefore, ARPA-E funds the development of technologies that, if technically successful, have clear disruptive potential, e.g., by demonstrating capability for manufacturing at competitive cost and deployment at scale.

ARPA-E funds applied research and development. The Office of Management and Budget defines “applied research” as an “original investigation undertaken in order to acquire new knowledge...directed primarily towards a specific practical aim or objective” and defines “experimental development” as “creative and systematic work, drawing on knowledge gained from research and practical experience, which is directed at producing new products or processes or improving existing products or processes.”¹ Applicants interested in receiving financial assistance for basic research (defined by the Office of Management and Budget as “experimental or theoretical work undertaken primarily to acquire new knowledge of the underlying foundations of phenomena and observable facts”)² should contact the DOE’s Office of Science (<http://science.energy.gov/>). Office of Science national scientific user facilities (<http://science.energy.gov/user-facilities/>) are open to all researchers, including ARPA-E Applicants and awardees. These facilities provide advanced tools of modern science including accelerators, colliders, supercomputers, light sources and neutron sources, as well as facilities for studying the nanoworld, the environment, and the atmosphere. Projects focused on early-stage R&D for the improvement of technology along defined roadmaps may be more appropriate for support through the DOE applied energy offices including: the Office of Energy Efficiency and Renewable Energy (<http://www.eere.energy.gov/>), the Office of Fossil Energy and Carbon Management (<https://www.energy.gov/fecm/office-fossil-energy-and-carbon-management>), the Office of Nuclear Energy (<http://www.energy.gov/ne/office-nuclear-energy>), and the Office of Electricity (<https://www.energy.gov/oe/office-electricity>).

B. PROGRAM OVERVIEW

1. SUMMARY

Technological advances in power electronics have enabled the unprecedented growth of renewable energy sources in the electrical power grid over the past several decades. Power electronics innovations have brought significant improvements in controllability, performance, and energy availability at a specific electronic interface, but are also fundamentally changing the nature of the grid as a system. Because of the growing proportion of *fast dynamic*

¹ OMB Circular A-11 (https://www.whitehouse.gov/wp-content/uploads/2018/06/a11_web_toc.pdf), Section 84, pg. 3.

² OMB Circular A-11 (https://www.whitehouse.gov/wp-content/uploads/2018/06/a11_web_toc.pdf), Section 84, pg. 3.

Questions about this FOA? Check the Frequently Asked Questions available at <http://arpa-e.energy.gov/faq>. For questions that have not already been answered, email ARPA-E-CO@hq.doe.gov (with FOA name and number in subject line); see FOA Sec. VII.A. Problems with ARPA-E eXCHANGE? Email ExchangeHelp@hq.doe.gov (with FOA name and number in subject line).

electronic interfaces relative to *slow dynamic* (i.e., conventional, asynchronous, machine-controlled) interfaces, grid performance, stability, and reliability are becoming increasingly jeopardized. This phenomenon is not restricted only to the grid. Modern electronic power distribution systems for airplanes, ships, electric vehicles, data centers, and homes contain potentially hundreds of power electronics converters. The inclusion of power electronics in a multitude of new areas is driven by gains in performance, efficiency, and reliability, in concert with reductions in size, weight, and operational costs.

The goal of this FOA, entitled Unlocking Lasting Transformative Resiliency Advances by Faster Actuation of power Semiconductor Technologies (ULTRAFAST), is to advance the performance limits of silicon (Si), wide bandgap (WBG), and ultra-wide bandgap (UWBG) semiconductor devices³ and significantly improve their actuation methods to support a more capable, resilient, and reliable future grid. This new program seeks to engage technical experts from power electronics, optoelectronics, photonics, and other related fields to support the development of next-generation ultra-fast semiconductor devices and modules for enhanced resiliency, reliability, and control of power flow at all grid interfaces.

ARPA-E expects that ULTRAFAST projects will create new material, device, and/or power module technologies that enable realization of transformative power management and control not only to enable a dramatically improved grid, but also for future autonomous power distribution systems such as those for electric vehicles, all-electric aviation, and others. More specifically, ARPA-E is looking for semiconductor material, device and/or power module level advances to enable faster switching and/or triggering at higher current and voltage levels for improved control and protection of the grid.

This program will support the development of technologies that enable semiconductor devices and/or modules capable of operating at high switching frequencies, and featuring high slew-rates, current, and voltage levels while mitigating electromagnetic interference (EMI) issues.

Specific categories include: (1) device and/or module technologies targeting protection functions at high current and voltage levels by achieving very fast by-pass, shunt, or interrupt capability at as low level of integration as possible with nanosecond-level reaction time (and corresponding slew rates). (2) high switching frequency devices and/or modules which enable efficient high-power, high-speed power electronics converters. These devices, depending on the power level, are required to switch between 1 kHz and 100 kHz in order to enable improved large-signal bandwidth of power converters for grid applications. Lastly, complementary technologies in category 3 such as wireless sensing of voltage and current, high-density packaging with the integrated wireless actuators and device/module-level protection, power cell-level capacitors and inductors, and thermal management strategies to support those in categories 1 and 2.

³ J.Y. Tsao, et al., Ultrawide-Bandgap Semiconductors: Research Opportunities and Challenges, *Adv. Electron. Mater.*, 4, 1600501 (2018) <https://doi.org/10.1002/aelm.201600501>.

This program supports ARPA-E mission goals to improve resilience, reliability, and security of energy infrastructure; improve energy efficiency; reduce greenhouse gas emissions; reduce reliance on energy imports; and maintain U.S. leadership in energy technologies.

2. BACKGROUND

The United States' electric grid faces a host of challenges, including aging infrastructure, increasing frequency of severe weather events, and emerging cyber and physical threats. Much of the grid is more than 60 years old⁴, weather-related power outages increased 78% in the last decade⁵, and recent cyber⁶ and physical⁷ attacks further expose grid vulnerabilities. Electricity customers in the U.S. experienced an average of seven hours of power disruptions in 2021⁸ with resulting impacts to health⁹ and major economic consequences – ultimately costing the U.S. an ~\$150 billion annually¹⁰. Emerging threats, such as electromagnetic pulses and space weather events could result in even more disastrous, large-scale impacts.

Such concerns will be greatly exacerbated in the future as the U.S. strives to achieve Net Zero Emissions (NZE) by 2050. Decarbonization efforts rely on the electrification of everything from transportation to industrial processes to urban infrastructure, causing a dramatic increase in demand for electricity. The share of electrified final power consumption is expected to increase from 20% today to 50% by 2050¹¹. Widespread adoption of carbon capture and sequestration technologies will further increase future electricity demand. It has also been recognized that reaching NZE by 2050 is predicated on greater penetration of renewable energy such as intermittent wind and solar distributed energy resources (DERs)¹². Increased share of DERs and electrified loads will require concomitant increases in transmission capacity and more flexible

⁴ Report Card for America's Infrastructure, ASCE, 2021. <https://infrastructurereportcard.org/wp-content/uploads/2020/12/Energy-2021.pdf>.

⁵ Surging Power Outages and Climate Change, Climate Central, 2022. <https://assets.ctfassets.net/cxgxtg8r5d/73igUswSfOhdo7DUDVLwK7/bb0a4e95e1d04457e56106355a1f74b9/2022PowerOutages.pdf>.

⁶ R. Walton, Colonial Pipeline hack highlights grid disruption risks even with IT-focused cyberattack, *Utility Dive*, May 11, 2021 <https://www.utilitydive.com/news/colonial-pipeline-hack-highlights-grid-disruption-risks-even-with-it-focuse/599942/>

⁷ M. Wilson, N.C. substation attack exposes grid risks, *E&E News*, Dec. 12, 2022 <https://www.eenews.net/articles/n-c-substation-attack-exposes-grid-risks>.

⁸ R. Berry, Today in Energy, EIA (2022) <https://www.eia.gov/todayinenergy/detail.php?id=54639>.

⁹ K. Siegel, The true cost of power outages. *Yale Environmental Review*, Aug. 5, 2012, <https://environment-review.yale.edu/true-cost-power-outages-0>.

¹⁰ Department of Energy Report Explores U.S. Advanced Small Modular Reactors to Boost Grid Resiliency, Jan. 25, 2018, <https://www.energy.gov/ne/articles/department-energy-report-explores-us-advanced-small-modular-reactors-boost-grid>.

¹¹ IEA (2022), *World Energy Outlook 2022*, IEA, Paris, CC BY NC SA 4.0 (Annex A), <https://www.iea.org/reports/world-energy-outlook-2022/an-updated-roadmap-to-net-zero-emissions-by-2050>.

¹² IEA, Net-Zero-by-2050, report, 2021. <https://www.iea.org/reports/net-zero-by-2050>.

grid infrastructure. To stay on target to meet emissions reductions, electricity transmission systems must increase capacity by 60% by 2030¹³ and expand more than three times by 2050¹⁴.

At high and medium voltage (H/MV) levels, power flow across the grid is currently routed by substations with limited regulation capabilities, relying on traditional electromechanical gear, low-frequency transformers, and slow protection equipment with reaction times of several line cycles. As a result, the grid's ability to quickly control, absorb, reroute, and isolate power flow and react to perturbations is limited, which can result in cascading power failures. Some parts of the grid are already being challenged by the current levels of renewables in use. These challenges will only grow as more renewables are brought on-line and fossil baseload plants shut down. Consequently, new technology is needed to improve grid control, resilience and reliability, and significantly faster power electronics are a critical enabling technology to achieve these qualities. Solid-state substations¹⁵ utilizing power electronics-based conversion could address these limitations, increase grid resilience and reliability, and facilitate superior control and protection capabilities.

Growth of power electronics-based interfaces will be driven by the need to connect new DERs and new electrified loads to the grid, as it is expected that 80% of electricity will flow through power electronics by 2030¹⁶. Power electronic conversion systems are capable of decoupling dynamics between system sources, distribution, and loads, while improving system controllability, reliability, resilience, and efficiency. These benefits are already being realized in a variety of applications, such as electric cars, ships, and airplanes, where power electronics replace traditional thermal, mechanical, hydraulic, and pneumatic systems. To realize these benefits in grid applications, new approaches are needed to create power electronics with improved performance (i.e., operation at voltages and currents at H/MV levels) and faster actuation speeds (enabling more sophisticated control and protection methods and reducing converter size, weight, and power (SWaP) consumption). Increased flexibility, control and efficiency gains afforded by power electronic interfaces have the potential to minimize the required level of transmission and distribution line build out to meet NZE goals by 2050, thus resulting in significant cost savings.

a) CURRENT APPROACH

A semiconductor switching device is a key element of any power electronic system, which determines the frequency and power level of operation, as well as a significant portion of the converter loss. Silicon has been the semiconductor material of choice for power devices for quite some time due to cost, fabrication, and process maturity. Silicon devices are, however,

¹³ M. Seltzer, Big but affordable effort needed for America to reach net-zero emissions by 2050, Princeton study shows, Dec. 15, 2020. <https://www.princeton.edu/news/2020/12/15/big-affordable-effort-needed-america-reach-net-zero-emissions-2050-princeton-study>

¹⁴ New Energy Outlook (2022), Bloomberg News & Energy Finance, <https://about.bnef.com/new-energy-outlook>.

¹⁵ Energy.gov., Solid-state Power Substation Technology Roadmap, 2020.

<https://www.energy.gov/oe/downloads/solid-state-power-substation-technology-roadmap>.

¹⁶ Energy.gov., Solar Power Electronic Devices, <https://www.energy.gov/eere/solar/solar-power-electronic-devices>.

reaching their operational limits in blocking voltage capability, temperature of operation, and switching frequency due to the intrinsic material properties of Si.

As shown in Table I, the relatively low bandgap and critical electric field of Si compare unfavorably to WBG and UWBG materials. Thus, vertical Si high voltage devices relying on majority carriers (unipolar devices such as field effect transistors, or FETs) require substantial epitaxial thicknesses, leading to higher specific on-resistance and higher conduction losses. To lower conduction losses, large device die areas are used, increasing the gate capacitance and charge, and resulting in increased switching losses and limiting switching frequency. Minority carrier-based power Si devices (bipolar devices such as insulated-gate bipolar transistors, or IGBTs, and thyristors) can have smaller device sizes but the long lifetime of minority carriers in Si reduces the usable switching frequency range to <10 kHz. The relatively low Si bandgap contributes to higher intrinsic carrier concentrations at elevated junction temperatures causing high leakage currents in p-n junctions. Current Si devices cannot reach the current and voltage levels required by H/MV grid applications, requiring series and/or parallel stacking of multiple devices in multi-level modules. This poses challenges to reliability and introduces additional complexity and cost due to increased part count.

TABLE 1. Properties of Si and common WBG/UWBG semiconductors^{1,17,18}

Parameter	Si	GaAs	4H-SiC	GaN	AlGaIn/AlN	β -Ga ₂ O ₃	Diamond	h-BN
Bandgap, E _g (eV)	1.1	1.4	3.3	3.4	3.4-6.1	4.8	5.5	~5.9
Critical Electric Field, E _c (MV/cm)	0.3	0.4	2.2	3.9	3-12	~6.7-15	5-10.1	~12
Thermal Conductivity, λ (W/m·K)	150	46	490	230	253-319	11-27	2290-3450	~750 (in-plane)
State-of-the-Art Substrate Diameter (mm)	450	300	200	200 (on Si) 100 (Bulk)	50.8	100	25.4	100

Opportunities for higher performing devices have emerged with the development of WBG semiconductors³ (i.e., silicon carbide (SiC) and gallium nitride (GaN)) and UWBG semiconductors (i.e., aluminum gallium nitride (AlGaIn/AlN), diamond, gallium oxide (β -Ga₂O₃), and boron nitride (h-BN)). These semiconductors have superior electrical and thermal characteristics, as shown in Table 1, that can circumvent the material limits of Si and offer attractive alternatives for realization of power devices for grid applications. However, the development of WBG and UWBG materials is relatively immature and still at a nascent stage. In particular, the latter suffer from significant challenges, for example, difficulty with doping, material quality, cost, and consequently manufacturability.

The higher critical electric fields in these semiconductors enable thinner, more highly doped voltage-blocking layers, which can reduce on-resistance by an order of magnitude in majority carrier architectures relative to equivalent Si devices. High breakdown electric field and low

¹⁷ O. Slobodyan, et al. Analysis of the dependence of critical electric field on semiconductor bandgap, Journal of Materials Research, 2022. <https://doi.org/10.1557/s43578-021-00465-2>.

¹⁸ A. Ranjan, et al. Dielectric Breakdown in Single-Crystal Hexagonal Boron Nitride, ACS Applied Electronic Materials, 2021. <http://doi.org/10.1021/acsaelm.1c00469>.

Questions about this FOA? Check the Frequently Asked Questions available at <http://arpa-e.energy.gov/faq>. For questions that have not already been answered, email ARPA-E-CO@hq.doe.gov (with FOA name and number in subject line); see FOA Sec. VII.A. Problems with ARPA-E eXCHANGE? Email ExchangeHelp@hq.doe.gov (with FOA name and number in subject line).

conduction losses mean these semiconductors can achieve the same blocking voltage and on-resistance with a smaller device area and thus lower capacitance. This reduced capacitance allows at least an order of magnitude higher frequency and faster response operation compared to a Si device. The low intrinsic carrier concentration of these semiconductors enables reduced leakage currents and robust high-temperature performance. The properties of the WBG and UWBG semiconductors permit devices to operate at much higher voltages, frequencies, and temperatures providing a pathway to more efficient, lighter, smaller, and higher temperature capable power electronics for H/MV grid applications.

While WBG semiconductors can push device performance to higher voltage and current levels, relative to Si, UWBG semiconductors are even more attractive due to their superior properties, specifically higher bandgap energy (E_g). Because many of the figures-of-merit for device performance scale with increasing E_g in a highly non-linear manner, the UWBG materials have the potential for far superior performance.

Despite superior performance relative to Si devices, WBG devices have been slow to penetrate the market, and commercial-off-the-shelf (COTS) parts are limited to 3.3 kV. Both COTS or engineering samples (up to 10 kV) have not been widely adopted in the grid applications, mostly due to cost¹⁹, immaturity and scarcity of reliability data, and lack of manufacturing and supply ecosystem, although that is beginning to change, driven by rapid growth of electrified vehicles²⁰. Thus, improvements in performance are expected to facilitate adoption in multiple applications providing more reliability data, supporting growth in manufacturing and supply chain, and eventually bringing the cost down through economies of scale.

A promising approach to realization of future solid-state substations relies on converter implementation using Modular Multi-level Converters (MMC)²¹ architectures. Today's power converters for H/MV levels commonly employ MMC architectures due to their modular structure and scalability to much higher voltage through stacking of power cells (Fig. 1a). Each power cell (Fig. 1b), a basic building block of the MMC, can be independently controlled and consists of a power module (Fig. 1c) and local energy storage unit that contributes a portion of the full stack voltage of the MMC as well as protection, sensing and control elements. Half-bridge (shown in Fig. 1b) or full-bridge power cell architectures are typically used for MMC structures. Power modules (Fig. 1d) themselves are comprised of semiconductor devices/dies. Due to their superior flexibility, modularity, and scalability, MMCs have been displacing other converter topologies in industrial applications. For grid applications, practically all voltage source modular converters contain power modules utilizing many 3.3 kV, 4.5 kV, or 6.5 kV Si IGBT devices/dies in parallel to enable conduction of hundreds, even thousands of amperes. However, reliability of modular multi-level converters (including cascaded H-bridge, flying capacitor, and other) significantly declines when number of components that comprise them

¹⁹ <https://www.eetimes.com/examining-whats-behind-sic-market-growth>

²⁰ <https://www.statista.com/outlook/mmo/electric-vehicles/worldwide>

²¹ Szykiel et al. - Modular Multilevel Converter Modelling, Control and Analysis under Grid Frequency Deviations. 2013 https://backend.orbit.dtu.dk/ws/portalfiles/portal/18266187/Modular_Multilevel_Converter.pdf

increases²². Another significant performance limiter is related to Electromagnetic Interference (EMI)²³ associated with operation at high power and frequency. EMI issues are partially responsible for underutilization of current WBG devices as additional circuit complexity is needed to mitigate them.

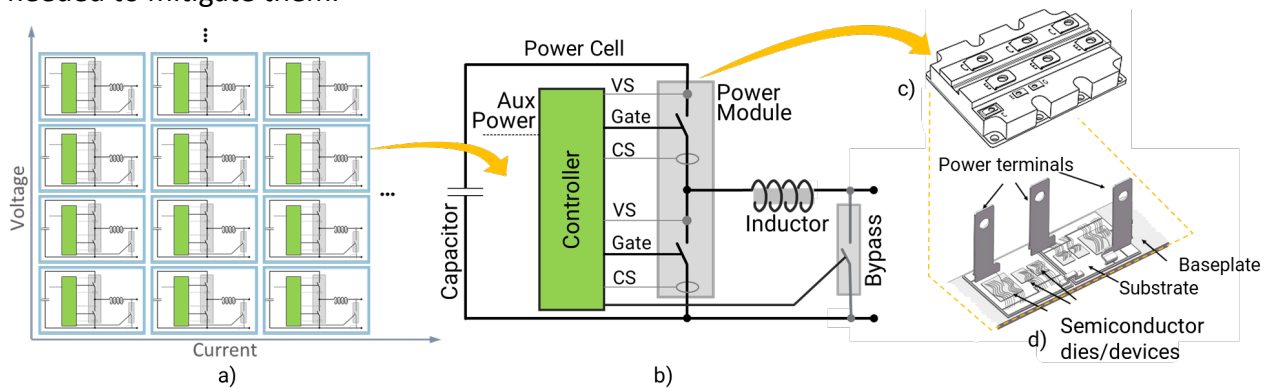

Figure 1. a) Modular Multi-level Converter structure, b) Half-bridge power cell, and Illustrations of c) Power module, and d) Devices/dies

Increasing the operating current and voltage rating of power electronic devices, while decreasing the switching times, results in increased current and voltage slew-rates (dv/dt and di/dt) during on-off transitions as shown in Fig. 2a. Rapid switching offers a big opportunity for reduction of device switching (and consequently overall) losses, relaxes stringent thermal management requirements, and improves converter power density, but causes radiated and conducted high-frequency EMI. This leads to noise generation and its propagation through gate drivers, sensors, controller boards, etc., unpredictably altering their functions and degrading converter reliability to the point where the system ceases to function properly or experiences catastrophic failures²⁴. This problem (Fig. 2b) is mostly caused by wires, or printed circuit board traces located in the vicinity of noise sources (devices), in which pulsating magnetic flux caused by high di/dt can inflict significant high frequency noise, and where any capacitive coupling establishes a path to high frequency currents driven by high dv/dt . This is one of the main factors preventing widespread adoption of WBG devices in circuits. A common mitigation involves “slowing down” of switching performance by adding sufficiently large gate resistance²⁵ into driving circuitry, thus negating key advantages of WBG-based devices. Some other “patches” or attempts to deal with the unwanted noise consist of filtering, shielding, and noise cancellation schemes.

²² Alavi, O.; Hooshmand Viki, A.; Shamlou, S. A Comparative Reliability Study of Three Fundamental Multilevel Inverters Using Two Different Approaches. *Electronics* 2016. <https://doi.org/10.3390/electronics5020018>.

²³ F. Zare - EMI Issues in Modern Power Electronic Systems. <https://www.emcs.org/acstrial/newsletters/spring09/pp2.pdf>.

²⁴ B. Zhang and S. Wang, "A Survey of EMI Research in Power Electronics Systems With Wide-Bandgap Semiconductor Devices," in *IEEE Journal of Emerging and Selected Topics in Power Electronics*, vol. 8, no. 1, pp. 626-643, March 2020, doi: 10.1109/JESTPE.2019.2953730.

²⁵ W. Ma, et. al., "Investigation of the Gate Resistance and the RC snubbers on the EMI Suppression in Applying of the SiC MOSFET," *IEEE ICMA*, 2019.

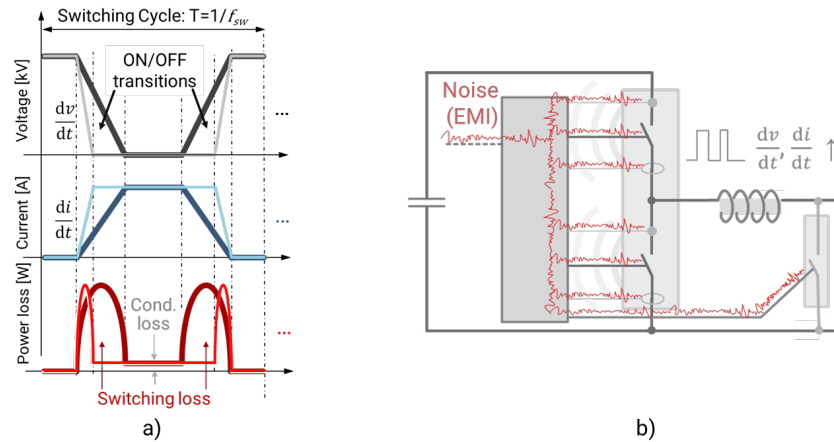

Figure 2. a) Switching transitions (slew-rates), b) Noise (EMI) propagation through power cell components

Because individual devices are not capable of achieving required current levels, they are commonly stacked in parallel configuration inside the power module package. Although both unipolar and bipolar devices can be paralleled, this is easier for unipolar devices as their positive temperature coefficient supports natural current sharing.

Stacking dies inside the power modules to achieve higher voltages is not a common practice due to difficulties with dynamic voltage balancing. Some attempts to stack SiC metal-oxide-semiconductor field-effect transistor (MOSFET) modules required additional, active gate control circuitry for each device in the stack to implement a closed-loop controlled voltage balancing²⁶. While effective, this method significantly increases system complexity and EMI susceptibility.

b) OTHER SIMILAR ACTIVITIES

Since its inception, ARPA-E has been a catalyst for applied technological breakthroughs in the domain of WBG and UWBG devices, launching SWITCHES²⁷, PN DIODES²⁸, CIRCUITS²⁹, BREAKERS³⁰, and other programs in the past decade. It invested more than \$200 Million dollars in over 100 projects, not only enabling significant technological progress in power electronics, but advancing commercialization and supporting the U.S. technological leadership in advanced power conversion technologies.

²⁶ K. Sun et al., "Modeling, Design, and Evaluation of Active dv/dt Balancing for Series-Connected SiC MOSFETs," in IEEE Transactions on Power Electronics, vol. 37, no. 1, pp. 534-546, Jan. 2022, doi: 10.1109/TPEL.2021.310024.

²⁷ "Strategies for Wide Bandgap, Inexpensive Transistors for Controlling High-Efficiency Systems," ARPA-E, U.S. Department of Energy, <https://arpa-e.energy.gov/technologies/programs/switches>.

²⁸ "Power Nitride Doping Innovation Offers Devices Enabling SWITCHES", ARPA-E, U.S. Department of Energy, <https://arpa-e.energy.gov/technologies/programs/pndiodes>.

²⁹ "Creating Innovative and Reliable Circuits Using Inventive Topologies and Semiconductors", ARPA-E, U.S. Department of Energy, <https://arpa-e.energy.gov/technologies/programs/circuits>.

³⁰ "Building Reliable Electronics to Achieve Kilovolt Effective Ratings Safely", ARPA-E, U.S. Department of Energy, <https://arpa-e.energy.gov/technologies/programs/breakers>.

The goals of this FOA are complemented by other previous and current program activities. The scope of this program, however, is distinct from all programs described below, in that it seeks to build upon and advance the current state of the art in materials, devices, and modules developed with the support of previous programs; in particular, the simultaneous focus on improved power handling and temporal performance *while mitigating EMI limitations* distinguishes this FOA from other efforts, and is critical to solving applied problems with respect to the grid. Successful outcomes will enable converters significantly less susceptible to EMI due to wireless/optical implementation of actuation, sensing, and auxiliary power supply. This minimizes paths for high-frequency noise generation and propagation through control circuitry, as well as facilitates higher switching slew-rates resulting in higher efficiency and better converter performance. Such capabilities will ultimately support realization of transformative power management, protection, and control for the new microgrids/grids as well as other autonomous power distribution systems, such as those for electrified transportation. A summary of complementary past and current programs by other offices at the DOE and Department of Defense (DOD) is presented below.

The DOE Office of Electricity's (OE) Transformer Resilience and Advanced Components (TRAC)³¹ research program is focused on grid modernization by addressing two main goals: increasing resilience of aging assets and identification of new requirements for future grid components, and acceleration the research, development, and field validation of next-generation grid hardware technologies. The program focused on challenges with Solid-State Power Substations (SSPS)¹⁸ and their components, such as advanced power routers, medium-voltage direct-current (MVDC) converters, high performance devices, as well as sensing elements. Recently, OE announced a solar innovations program³² targeting development of the next generation of wide-bandgap power-electronic systems specifically to support integration of solar generation with energy storage and/or electric vehicle charging, as well as capabilities for quick recovery response to weather or cyber threat related grid outages.

DOE's Advanced Manufacturing & Industrial Decarbonization Offices founded PowerAmerica³³ Institute in 2015 to accelerate the commercialization of WBG semiconductor technology by developing advanced manufacturing processes for large-scale production of WBG semiconductors.

DOD's Office of Naval Research (ONR) investments under basic research focus on the development and improved reliability/availability of next-generation WBG semiconductors, advanced insulation systems and their prognostics, and development of improved, light-weight magnetic materials. Their applied research focuses on development and application of improved SWaP WBG-based Power Electronics Building Blocks (PEBB), and innovative Power

³¹ <https://www.energy.gov/sites/default/files/2019/12/f70/TRAC-Program-Overview.pdf>

³² <https://www.energy.gov/eere/solar/solar-topics-small-business-innovation-research-and-small-business-technology-transfer>

³³ <https://poweramericainstitute.org>.

Electronic Power Distribution System (PEPDS) technology and concepts that surpass conventional MVDC and MVAC³⁴.

ONR's interests complement those of ARPA-E to surpass state-of-the-art performance and further advance the power electronics field. These include development of methods, tools and materials to control electric field concentration in highly integrated, compact and power dense converters; advancement of WBG materials and devices for very high frequency, voltage and power applications; investigation of WBG semiconductor device failure modes; development of new materials for high temperature (>200° C), high electric field and low dielectric loss operation; improvement of reliability of power electronic devices, power density of power systems, and risk reduction for future application of MVDC systems³⁵.

The DOD's Defense Advanced Research Project's Agency (DARPA) has invested in WBG semiconductors for Radiofrequency (RF) applications in the Wide Bandgap Semiconductors for RF Applications (WBGs-RF) program that aimed to deliver higher power RF for electronic warfare and advanced radar systems in 2001. Beyond wide bandgap materials DARPA has invested in photonics and heterogeneous integration of materials that have the potential to impact this program. DARPA recently held a workshop on "UWBG Materials for High Performance Applications" at the 2021 Electronics Resurgence Initiative Summit & Microsystems Technology Office (MTO) symposium to address the outlook for UWBG materials for power electronics and RF in DOD and commercial applications³⁶.

The DARPA Photonics in the Package for Extreme Scalability (PIPES) program is combining photonics with packaged integrated circuits to enable performance gains in data transfer rates. With the goal of delivering 100 Tbps per package at energies of less than 1 picojoule per bit PIPES aims to disrupt current microelectronics and fully realize the potential of optical interconnects for advanced computing applications.³⁷ The Lasers for Universal Microscale Optical Systems (LUMOS) program aims to advance integrated photonics technology through intimate integration of optical gain sources such as lasers and amplifiers with capable photonics platforms. LUMOS is bringing complex, scalable optical gain to commercial foundries, as well as funding the integration of high-power Watt class gain and gain across the visible spectrum.³⁸ Both programs involve heterogeneous integration of electronic and photonic materials and devices which could provide useful partnering opportunities for potential applicants.

Like DARPA's PIPES program, ARPA-E's ENLITENED program targets development and co-packaging of photonic integrated circuits (PICs) and microelectronic integrated circuits for reduction of energy consumption of data centers and enablement of novel data center architectures supporting emerging computational requirements of artificial intelligence and

³⁴ <https://www.esrdc.com/library/pepds-plan>.

³⁵ <https://www.nre.navy.mil/organization/departments/code-33/division-331/power-electronics-and-electromagnetism>.

³⁶ [Kazior UWBG Workshop.pdf \(darpa.mil\)](#)

³⁷ [Photonics in the Package for Extreme Scalability \(darpa.mil\)](#)

³⁸ [Lasers for Universal Microscale Optical Systems \(darpa.mil\)](#)

machine learning with optimized energy consumption. Performers and technologies associated with this program offer a rich opportunity for collaboration.

Similarly, NSF's Electronics, Photonics and Magnetic Devices (EPMD) Program³⁹ supports innovative research on fundamental research on novel (micro-, nano-, and quantum-) devices based on the principles of electronics, optics and photonics, optoelectronics, magnetics, electromagnetics, and related physical phenomena looking to advance, among others, wide/extreme-bandgap semiconductor devices. Another office funding fundamental research is DOE's Basic Energy Sciences (BES) office with their recent Energy Frontier Research Center (EFRC) effort⁴⁰, bringing together disciplinary scientific teams to tackle the toughest scientific challenges in energy technologies including those related to ultra-wide-bandgap and wide-bandgap materials.

C. PROGRAM OBJECTIVES

1. TECHNOLOGY DEVELOPMENT

The target of this program is to support the development of devices and/or modules and supporting material technologies to create more capable building blocks for the future grid, as shown in Fig. 3. More specifically, ARPA-E is looking to provide support for material, device, and/or module level advances to enable faster switching and triggering at higher current and voltage levels to realize improved control and protection capabilities. Separate categories targeting faster switching for control and higher current and voltage slew rates for triggering and protection, both at higher voltage and current ratings, are envisioned to allow for the broadest range of approaches, although technology developments that can simultaneously address both necessary functions are preferred.

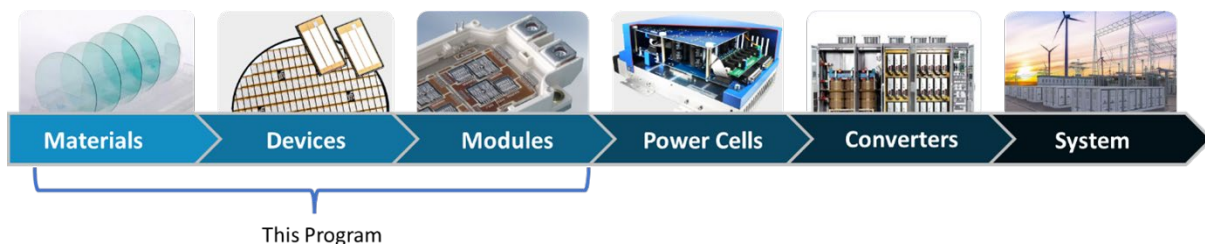

Figure 3. Scope of this program, relative to higher levels of integration

Individual device performance at higher voltage and current ratings is desired to reduce the number of devices stacked in series and parallel combinations in modules, and in stacked modules in power cells/converters, required to achieve H/MV power levels in grid applications. Reducing the required number of devices and modules will be necessary to improve overall system reliability, complexity, and cost. Increased switching speed is desired to continue the trend of shrinking converter sizes with increased switching frequencies, as has been

³⁹ <https://beta.nsf.gov/funding/opportunities/electronics-photonics-magnetic-devices-epmd-0>

⁴⁰ <https://science.osti.gov/bes/efrc>

demonstrated by replacing slower Si devices with faster switching WBG devices. This is a consequence of devices/modules switching at higher frequencies, while keeping the loss low, and subsequent reduction in the required sizes of passives.

One approach to this problem (although not an exclusive one) involves the utilization of UWBG materials. UWBG materials have been long predicted to enable operation of devices at higher reverse blocking voltages and lower forward specific on-resistances than devices realized with WBG materials. This is due to the superior UWBG material properties, as indicated in Table I and discussed in Section I.B.

Despite such promising material characteristics, UWBG devices and fabrication techniques suffer from several issues. Some of these problems stem from their relative immaturity, and thus lower material quality, smaller, more expensive substrates, supply chain maturity, and manufacturability issues. They also suffer from more fundamental problems, such as doping difficulties, due to their ultra large bandgaps (~5-6 eV) and deep dopant states which result in incomplete room temperature ionization.

One way to address this problem is through optical excitation of carriers from their deep dopant states into the conduction and valence bands, where they are available to conduct current. This has been reported in the literature⁴¹. ARPA-E is interested in supporting projects that use this approach (or others, as there are other ways to address this problem) to accelerate realization of devices utilizing UWBG materials and can operate at elevated power levels and at higher switching speed, with low loss. Applicants choosing this approach should consider the power devices and the required optical source as a system and discuss its integration and packaging, as well as operation and functional requirements of both the power device and the optical source. These functional requirements include wavelength, optical power, temporal characteristics, electrical power consumption, thermal management, cost, reliability, and other relevant parameters.

To take advantage of increased switching speeds such as those possible with WBG and UWBG material-based devices, novel EMI mitigation solutions are desired. Increased switching speed is desired to continue reducing converter SWaP and decreasing switching losses (through decreasing switching times). Increasing the operating current and voltage while decreasing the switching time results in increased current and voltage slew rates (di/dt and dv/dt), exacerbating EMI problems. ARPA-E is interested in supporting the development of scalable, broadly applicable solutions which mitigate this issue, while simultaneously providing control and protection capabilities that operate at high switching rates, high slew rates, and current and voltage levels.

One way to minimize EMI impact is to eliminate or minimize wires, wire-loops, and printed circuit board traces from the driving and sensing circuitry located in proximity and/or

⁴¹ M.A. Bryushinin, et. al, Optically Induced Space-charge and Conductivity Gratings in Wide-bandgap Semiconductors, Physics Procedia, Volume 86, 2017. <https://doi.org/10.1016/j.phpro.2017.01.035>

electrically connected to high dv/dt nodes. Instead, wireless power and data transfer would occur between the control stage and the device/module gates, as well as to/from associated sensors. One of the more promising approaches to address this involves optical power and data transfer^{42,43}, although operation at other portions of the electromagnetic spectrum is of interest as well. In any case, ARPA-E expects that Applicants justify and explain how their solution helps improve the EMI immunity without introducing additional filters or shielding.

An important feature enabled by optical triggering is independent control of device voltage and current slew-rates achieved via a simple optical modulation. Independent control of dv/dt and di/dt enables fast dynamic voltage balancing and current sharing, facilitating not only simpler module stacking for higher voltages and currents but also combination of die-level cascading and paralleling inside the same package, potentially with a minimal EMI impact⁴⁴.

Multiple approaches to achieve the optical control and powering of devices and modules are possible. Fig. 4 shows some options, although these are intended only for illustrative purposes as many other different approaches could be realized.

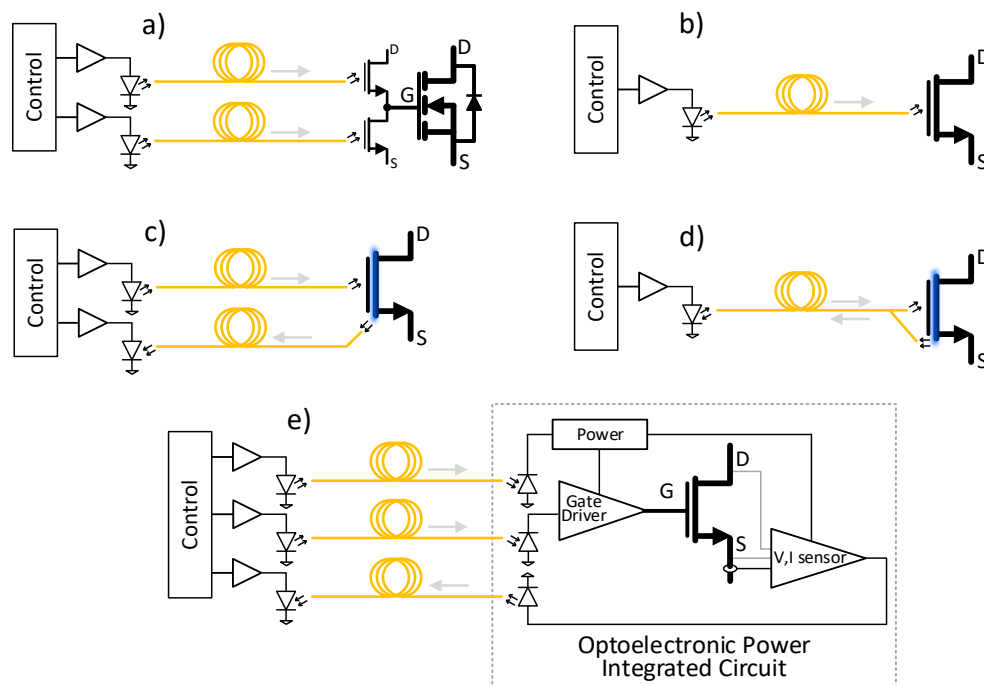

Figure 4. Various possible approaches to optical control and sensing

⁴² X. Wang, H. Pu, Q. Liu, L. An, X. Tang and Z. Chen, "Demonstration of 4H-SiC Thyristor Triggered by 100-mW/cm² UV Light," in IEEE Electron Device Letters, vol. 41, no. 6, pp. 824-827, June 2020, doi: 10.1109/LED.2020.2988913.

⁴³ S. K. Mazumder and T. Sarkar, "Optically Activated Gate Control for Power Electronics," in IEEE Transactions on Power Electronics, vol. 26, no. 10, pp. 2863-2886, Oct. 2011, doi: 10.1109/TPEL.2009.2034856.

⁴⁴ H. Riazmontazer and S. K. Mazumder, "Optically Switched-Drive-Based Unified Independent dv/dt and di/dt Control for Turn-Off Transition of Power MOSFETs," in IEEE Transactions on Power Electronics, 2015.

It is possible to supply power and data signal to an intermediate device which then drives the power device gate, as shown in Fig. 4a, as well as to control the device gate directly optically as shown in Fig. 4b. Fig. 4c, and Fig. 4d illustrate the possibility of optical sensing of the power device, either with a separate fiber from optical gate control (Fig. 4c) or with the same fiber (Fig. 4d).

Fig. 4e shows an intermediate option, where gate drive is optically powered as well as receives drive data optically, and then electrically drives the device, while optically sensing the device, via a dedicated fiber. In this case power devices, sensors, and gate driver are all integrated on a single chip, shortening the remaining electrical connections between them to minimize coupled EMI. Such functionality integrated on a single chip could be transformational, if it could show sufficient reduction of EMI effects, operation at desired speeds and power levels, and a path to scalability and eventual cost reduction. Leveraging technology from areas such as optoelectronics and PICs could provide interesting cross pollination opportunities for power electronics.

Photoconductive Semiconductor Switches (PCSS)^{45,46,47} and Light-Triggered Thyristors (LTT)⁴⁸ operate in a manner illustrated in Fig. 4b, and although PCSS have not yet reached performance targets of this program, they are very promising candidates. One of the key difficulties in reaching targeted performance levels will be showing sufficient charge to switch required current and voltage levels of the power device can be delivered to a power device gate in the prescribed amount of time. Additionally, the required optical (or other) system to execute this, should not be excessively bulky, complicated, inefficient, or incapable of eventual cost reduction.

2. TECHNOLOGY-TO-MARKET (T2M)

As an impact-focused agency, ARPA-E is interested in not only supporting the development of transformative technologies, but also enabling and facilitating their commercialization.

With over \$70 billion per year in capital investment by U.S. electric transmission and distribution utilities, there is a significant commercial opportunity for grid hardware that dramatically improves performance. However, development, testing, regulatory approval, and deployment of new power technologies for the grid takes time. Adjacent markets may provide earlier commercial entry points crucial for development of supply chains, sales and service infrastructure, and operational experience. Some examples of these market segments include, Industrial, Aerospace & Defense, Automotive and Transportation, as well as Information and

⁴⁵ <https://www.osti.gov/biblio/522404>.

⁴⁶ <https://www.kymatech.com/about/faqs/425-what-is-a-photoconductive-semiconductor-switch-pcss>.

⁴⁷ <https://www.nist.gov/noac/technology/quantum-optics-and-radiometry/photoconductive-switches>.

⁴⁸ Triggering Light-Triggered Thyristors, Infineon Application Note. https://www.infineon.com/dgdl/Infineon-AN2018-07_Triggering_LTTs-ApplicationNotes-v07_00-EN.pdf?fileId=5546d4626cb27db2016cdce3b8e72e3d

Communication Technology. This overall market is projected to grow from \$34.7 billion in 2017 to \$46.8 billion in 2027⁴⁹.

Grid expansion is included in the 'Industrial' category of the market segments. Though not a major contributor in this decade, grid expansion will become a major segment of the market as the nation progresses towards 'Grid 3.0'⁵⁰. Nonetheless, commercial barriers for market entry are significant and may include:

- Risk-averse industry with very high safety and reliability requirements for market entry.
- Heavily regulated market with complex capital investment approval processes and extensive new technology demonstration and piloting requirements.
- Competitive supplier base subject to public procurement processes focused on cost minimization.

As part of the T2M section in the Full Application, applicant teams should identify the intended new products and use cases for the electric power grid that will result from their proposed technologies.

Submissions should provide an assessment of the system impact enabled by the proposed device/module technology, discussion of reliability issues and potential mitigations⁵¹, and system-level cost benefit. It is expected that performers consider the cost assessment of the technology they are proposing including but not limited to the cost of manufacturing process, equipment, material, etc. As part of the tech-to-market strategy, selected submissions are expected to continue these types of efforts for the entire period of performance. To facilitate success in these areas, ARPA-E strongly encourages early and consistent engagement with system integrators, end users, and relevant stakeholders. Partnering with existing manufacturers of power electronics and associated systems is encouraged to streamline supply chain development and identify future sales and servicing capabilities. Outreach to end users, including grid equipment providers, system integrators, and utilities, is also encouraged as Applicants develop their T2M plans.

D. TECHNICAL CATEGORIES OF INTEREST

Category 1 seeks submissions for devices and/or modules for protection functions. As such, ARPA-E desires functionality that enables very fast bypass, shunt, or interrupt capability at as low a level of integration as possible. The type of operation will drive efficiency and reliability requirements. For example, protection device/module operating in-line is expected to function with efficiencies higher than 99% to minimize conduction loss and consequent thermal

⁴⁹ <https://www.kbvresearch.com/power-electronics-market>

⁵⁰ <https://smartgrid.ieee.org/about-ieee-smart-grid/history/news/a-summary-of-the-grid-3-0-workshop>

⁵¹ H. Wang and F. Blaabjerg, "Power Electronics Reliability: State of the Art and Outlook," in IEEE Journal of Emerging and Selected Topics in Power Electronics, vol. 9, no. 6, pp. 6476-6493, Dec. 2021, doi: 10.1109/JESTPE.2020.3037161.

management requirements. For protection devices that are shunt-connected, voltage withstand capability, very low leakage current, and extremely fast turn-on are essential attributes. Experimental validation of developed device and/or module performance is expected for both types of protection devices, and product lifetime of fault handling should be illustrated through at least 30,000 operating (on-off) cycles with specified reliability. Because advances in category 1 target protection functions, they are expected to operate infrequently, thus their temporal performance is characterized by how quickly they can reach their final state, that is by the current and voltage slew rates rather than by switching speed. Targeted voltage and current levels are fully described in the next section.

Category 2 addresses the need for switching devices and/or modules which will be used to realize building blocks of the control infrastructure for the future grid. Thus, depending on the power level, devices and/or modules are required to switch between 1 kHz and 100 kHz to enable increased large-signal bandwidth of power electronics converters for grid applications. High efficiency is paramount, and total loss (both switching and conduction) of device/module must be at least 30% lower than state of the art (SOTA), and Applicants need to provide justification (preferably backed by experimental or simulation evidence) in their submissions that this improvement is achievable. Product life will be assessed through a device/module lifetime with 168 hours of continuous operation with proposed reliability relevant to target application. Category 2 devices or modules can additionally feature some or all protection functions from category 1, offering a switch with unparalleled performance specifications. Experimental validation of device and/or module performance is expected. This can encompass verification of performance at the next level of system integration, such as a circuit, for example a buck, boost, half/full-bridge or other, relevant, converter structure. Teams should have an experimental plan and justification considering a potential technology application. There is not an explicit metric on the EMI mitigation, as meeting existing standards⁵² is insufficient to ensure reliable, false trigger free operation of multiple devices and modules integrated into a converter. However, it is expected that final experimental validation will showcase EMI mitigation through reliable operation of multiple devices and/or modules in the next level of integration. Successful submissions should include adequate discussion of EMI issues specific to the SOTA in proposed work, chosen mitigation strategy, its scalability, as well as means of showing improved EMI performance, while meeting other program metrics.

Category 3 targets supporting technologies for category 1 and category 2, such as wireless sensing of device voltage and current, high-density packaging of multi-die power modules with the integration of wireless actuators and device/module-level protection, power cell-level capacitors and inductors, and thermal management strategies. While category 3 is distinct, it is expected that capabilities developed therein will be realized in a system context corresponding to the next level of integration, such as devices/modules developed in categories 1 and 2, or via suitable alternatives and overall experiment strategy. Thus, performance targets for category 3 encompass and support those for categories 1 and 2.

⁵²The EMC Standards List: Common Standards and Their Significance. <https://resources.system-analysis.cadence.com/blog/msa2021-the-emc-standards-list-common-standards-and-their-significance>.

ARPA-E is also interested in submissions that propose innovations on the device concepts that promise performance at the required levels. Novel device concepts that span across categories are encouraged, as are ideas that allow incorporation of protection functions within a device or module. Applicants are expected to provide some evidence that the proposed approach will be successful, either in the form of prior experimental results, calculations, simulations, or models. While new approaches are desired, ARPA-E will consider ideas based on prior art but expects an explanation as to what is different and why it is expected to succeed where others have failed. The following gives examples of potential areas of interest for this FOA. These examples are meant to be illustrative and are by no means exhaustive (all must target required performance levels):

- (U)WBG devices (and compact models, validated by experimental performance)
- Novel device structures (and compact models, validated by experimental performance) that offer improved functionality for control and triggering, ideally integrated at lowest possible level
- Wireless means of control and/or triggering (possibly optical, but other methods may be considered) of power electronic devices/modules
- Wireless sensing of parameters relevant to device/module control and triggering
- On-chip integration of optical (or other) and electrical functionality required
- Modeling coupled with experimental validation to elucidate fundamental device performance understanding
- Advances in passives technology experimentally validated in the context of appropriate device/module
- Thermal management approaches experimentally validated in the context of appropriate device/module
- Advances in electric field and partial discharge management at a package level

See Section III.C.3 for Submissions Specifically Not of Interest.

E. TECHNICAL PERFORMANCE TARGETS

Desired device/module voltage and current ratings are depicted in Figs. 5a and 5b, corresponding respectively to devices/modules for protection under category 1, and switching devices/modules for control under category 2. Axes limits shown in Figs. 5a and 5b, are notional and should not be interpreted as device/module rating limits, hence exceeding them is encouraged. Voltages on both y-axes represent the voltage at which a device/module can operate indefinitely, without significant device/module performance degradation (for instance, a negligible change in leakage current can be reported after the device has been exposed to this voltage for several hours). The current rating on both x-axes represents a continuous device/module current under which the junction temperature stays under certain limits determined by the device material properties, module structure, choice of the thermal management, etc.

In addition to voltage and current ratings, Fig. 5b defines a desired device/module switching frequency spanning from 1kHz to 100 kHz. The blue shaded area follows a color gradient defined by constant power isolines along which the device power rating is constant, and all voltage-current products feature the same switching frequency. As an example, the dotted line in the graph represents an isoline for a device/module rating of 1 MW, and where all of the rating options falling on this isoline should feature the same switching frequency defined by a colored bar guide shown to the right of Fig. 5b. ARPA-E will consider applications that trade off switching frequency and switching power, within specified limits, to allow performers flexibility in management of device/module loss without significant negative impact on the performance. However, favorable consideration will be given to technically aggressive submissions with well-justified, realistic plan to meet or exceed all technical targets within the time frame of the award.

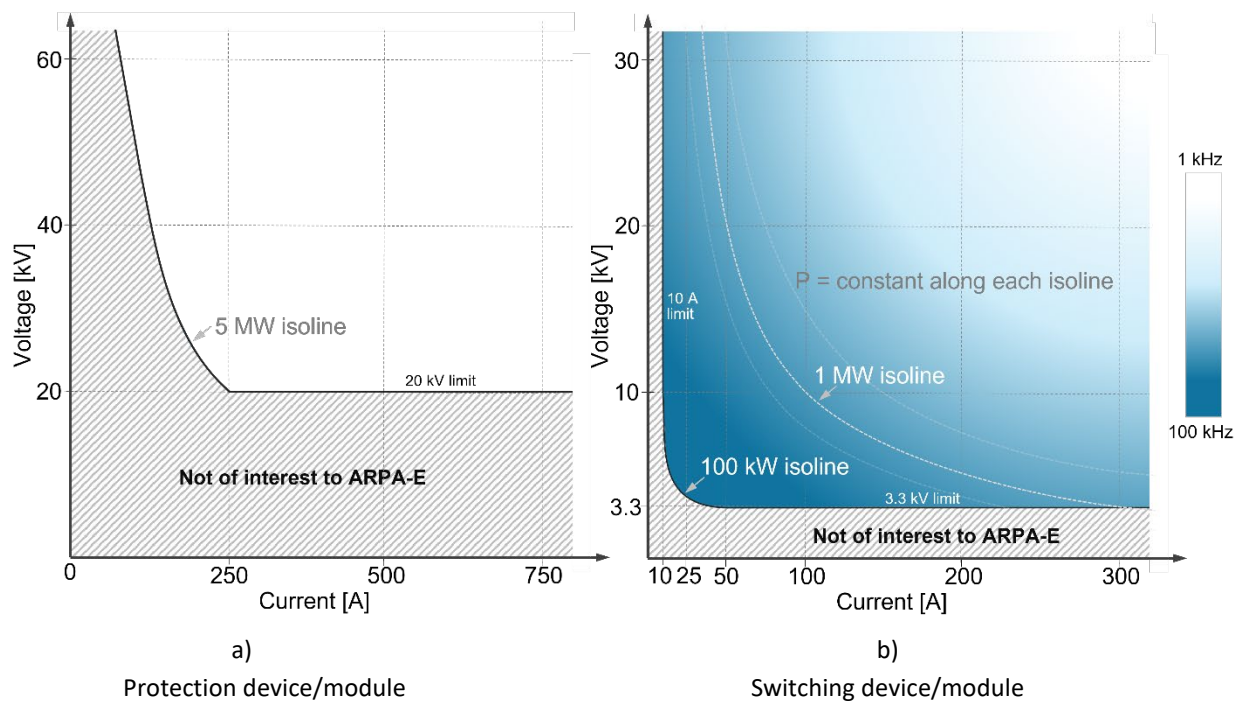

Figure 5. Device/module ratings domain

Definitions of device/module performance properties are shown in Fig. 6. Waveforms shown below are arbitrary and used here only as an example.

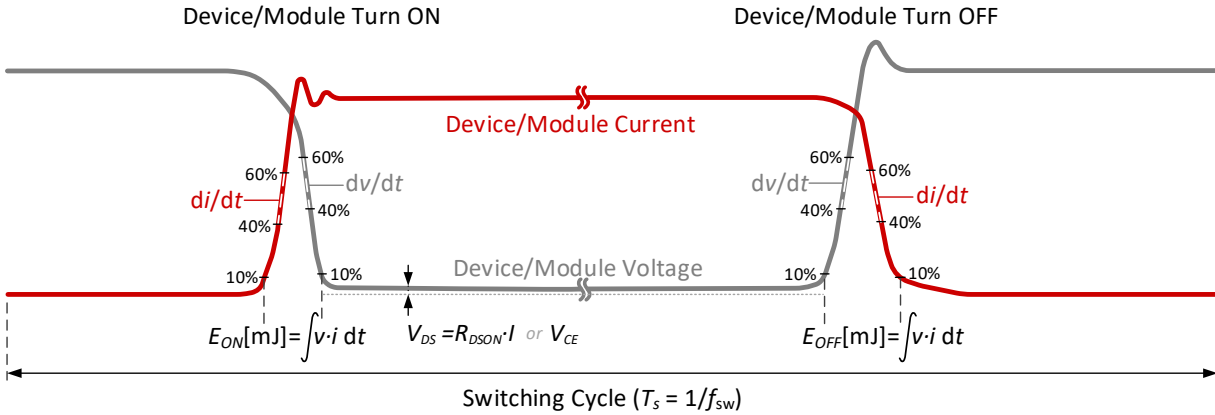

Figure 6. Device/module temporal properties

Program performance metrics summary:

CATEGORY 1		
Fast triggering for improved protection		
Voltage rating	≥ 20 kV	See Fig. 5a for further clarification. <i>Examples:</i> Single (discrete) device, multi-die power module with series and/or stacked dies, anti-series, anti-parallel device/module, bidirectional device, etc.
Current rating (continuous)	≥ 250 A	
Current rating (peak)	≥ 2500 A	
Efficiency for current carrying device/module (in-line) with infrequent switching	≥ 99%	Efficiency metric applies to a device/module Please justify based on use case. <i>Examples:</i> Series protection switch, solid-state circuit breaker, current limiting diode, commutation switch, etc.
Efficiency for voltage holding device/module (shunt) with infrequent switching	n/a	<i>Examples:</i> Solid-state surge arrester/transient voltage suppressor, voltage limiting diode, shunt protection switch, etc.
Voltage slew-rate	≥ 500 V/ns	Trading between the two slew-rates possible but requires justification.
Current slew-rate	≥ 200 A/ns	
Lifetime	≥ 30,000 cycles	Testing to be done in a relevant circuit with justification of the methodology.

Questions about this FOA? Check the Frequently Asked Questions available at <http://arpa-e.energy.gov/faq>. For questions that have not already been answered, email ARPA-E-CO@hq.doe.gov (with FOA name and number in subject line); see FOA Sec. VII.A. Problems with ARPA-E eXCHANGE? Email ExchangeHelp@hq.doe.gov (with FOA name and number in subject line).

CATEGORY 2 <i>Fast switching for improved control (higher bandwidth) and higher power density integration</i>		
Voltage rating	≥ 3.3 kV	See Fig. 5b for further clarification. <i>Examples:</i> Single (discrete) device, multi-die power module with series and/or stacked dies, anti-series, anti-parallel device/module, bidirectional device, etc.
Current rating (continuous)	≥ 10 A	
Switching frequency	1 kHz (10 MW) - 100 kHz (100 kW)	
Maximum total loss (switching and conduction)	≥ 30% lower than SOTA	Please justify. Where applicable, SOTA datasheet and/or publication information may be used for comparison.
Voltage slew-rate	≥ 250 V/ns	Trading between the two slew-rates possible but requires justification.
Current slew-rate	≥ 100 A/ns	
Lifetime	≥ 168 hours	Testing to be carried out in a relevant circuit with justification of the methodology.

CATEGORY 3 <i>Supporting technologies for categories 1 and 2</i>	
<i>Examples:</i> Wireless sensing of device voltage and current, high-density packaging of multi-die power modules with the integration of wireless actuators and device/module-level protection, power cell-level capacitors and inductors, thermal management strategies, etc.	
Developed capabilities are expected to be experimentally validated in a system context corresponding to the next level of integration, such as devices/modules developed in categories 1 and 2, or via suitable alternatives (for example COTS devices/modules). Performance targets for category 3 encompass and support those for categories 1 and 2, depending on the application.	

NOTE (relevant for all project categories):

ARPA-E is looking for technically aggressive, well-justified, submissions that achieve transformative advancements beyond the current state-of-the-art.

ARPA-E expects that technology developed with the support of this program will meet or exceed the reliability of SOTA. Thus, at a minimum, submissions should include a discussion of reliability assessment, influencing factors, and substantiated pathways to desired reliability for a relevant application. Quantitative analyses and/or experimental evidence are encouraged.

Efficiency target of 99% for category 1 is purposely chosen to encourage novel solutions (for example PCSS), but thermal considerations may favor higher efficiency performance.

Experimental validation of device and/or module should be carried out in a relevant circuit with justification of the chosen testing platform and the methodology. For example, devices/modules from category 1 can be tested in a double-pulse circuit, while devices from the

Questions about this FOA? Check the Frequently Asked Questions available at <http://arpa-e.energy.gov/faq>. For questions that have not already been answered, email ARPA-E-CO@hq.doe.gov (with FOA name and number in subject line); see FOA Sec. VII.A. Problems with ARPA-E eXCHANGE? Email ExchangeHelp@hq.doe.gov (with FOA name and number in subject line).

category 2 can be tested in a converter (simple buck or boost converters are acceptable). Testing conditions and thermal management are not prescribed by ARPA-E, however, the use of a regenerative (pump-back⁵³) testing structure is deemed most effective and is highly encouraged.

Applicants can propose to address Category 1, Category 2, Category 3, or any combination thereof if proposal is compliant with the requirements specified in this FOA.

⁵³ D. Pan, D. Zhang, C. Immer, M. Dame and J. He, "Pump-Back Validation of a Medium Voltage High-Frequency "SiC+Si" Hybrid Three-Level ANPC Inverter for Hybrid-Electric Propulsion Application," 2019 IEEE International Electric Machines & Drives Conference (IEMDC), 2019, pp. 1647-1654, doi: 10.1109/IEMDC.2019.8785332.

I. AWARD INFORMATION

A. AWARD OVERVIEW

ARPA-E expects to make approximately \$48 million available for new awards, subject to the availability of appropriated funds. ARPA-E anticipates making approximately 15-20 awards under this FOA. ARPA-E may, at its discretion, issue one, multiple, or no awards.

Individual awards may vary between \$250,000 and \$10 million in Federal share.

The period of performance for funding agreements may not exceed 36 months. ARPA-E expects to issue funding agreements in December 2023, or as negotiated.

ARPA-E encourages submissions stemming from ideas that still require proof-of-concept R&D efforts as well as those for which some proof-of-concept demonstration already exists.

Submissions requiring proof-of-concept R&D can propose a project with the goal of delivering on the program metric at the conclusion of the period of performance. These submissions must contain an appropriate cost and project duration plan that is described in sufficient technical detail to allow reviewers to meaningfully evaluate the proposed project. If awarded, such projects should expect a rigorous go/no-go milestone early in the project associated with the proof-of-concept demonstration. Alternatively, submissions requiring proof-of-concept R&D can propose a project with the project end deliverable being an extremely creative, but partial solution. However, the Applicants are required to provide a convincing vision how these partial solutions can enable the realization of the program metrics with further development.

Applicants proposing projects for which some initial proof-of-concept demonstration already exists should submit concrete data that supports the probability of success of the proposed project.

ARPA-E will provide support at the highest funding level only for submissions with significant technology risk, aggressive timetables, and careful management and mitigation of the associated risks.

ARPA-E will accept only new submissions under this FOA. Applicants may not seek renewal or supplementation of their existing awards through this FOA.

ARPA-E plans to fully fund the negotiated budget at the time of award.

B. RENEWAL AWARDS

At ARPA-E's sole discretion, awards resulting from this FOA may be renewed by adding one or more budget periods, extending the period of performance of the initial award, or issuing a new

Questions about this FOA? Check the Frequently Asked Questions available at <http://arpa-e.energy.gov/faq>. For questions that have not already been answered, email ARPA-E-CO@hq.doe.gov (with FOA name and number in subject line); see FOA Sec. VII.A. Problems with ARPA-E eXCHANGE? Email ExchangeHelp@hq.doe.gov (with FOA name and number in subject line).

award. Renewal funding is contingent on: (1) availability of funds appropriated by Congress for the purpose of this program; (2) substantial progress towards meeting the objectives of the approved application; (3) submittal of required reports; (4) compliance with the terms and conditions of the award; (5) ARPA-E approval of a renewal application; and (6) other factors identified by the Agency at the time it solicits a renewal application.

C. ARPA-E FUNDING AGREEMENTS

Through cooperative agreements, other transactions, and similar agreements, ARPA-E provides financial and other support to projects that have the potential to realize ARPA-E's statutory mission. ARPA-E does not use such agreements to acquire property or services for the direct benefit or use of the U.S. Government.

Congress directed ARPA-E to "establish and monitor project milestones, initiate research projects quickly, and just as quickly terminate or restructure projects if such milestones are not achieved."⁵⁴ Accordingly, ARPA-E has substantial involvement in the direction of every Cooperative Agreement, as described in Section II.D below.

1. COOPERATIVE AGREEMENTS

ARPA-E generally uses Cooperative Agreements to provide financial and other support to Prime Recipients.⁵⁵

Cooperative Agreements involve the provision of financial or other support to accomplish a public purpose of support or stimulation authorized by Federal statute. Under Cooperative Agreements, the Government and Prime Recipients share responsibility for the direction of projects.

ARPA-E encourages Prime Recipients to review the Model Cooperative Agreement, which is available at <https://arpa-e.energy.gov/technologies/project-guidance>.

2. FUNDING AGREEMENTS WITH FFRDCs/DOE LABS, GOGOS, AND FEDERAL INSTRUMENTALITIES

Any Federally Funded Research and Development Centers (FFRDC) involved as a member of a Project Team must provide the information requested in the "FFRDC Lab Authorization" and "Field Work Proposal" section of the Business Assurances & Disclosures Form, which is submitted with the Applicant's Full Application.

When a FFRDC/DOE Lab (including the National Energy Technology Laboratory or NETL) is the

⁵⁴ U.S. Congress, Conference Report to accompany the 21st Century Competitiveness Act of 2007, H. Rpt. 110-289 at 171-172 (Aug. 1, 2007).

⁵⁵ The Prime Recipient is the signatory to the funding agreement with ARPA-E.

lead organization for a Project Team, ARPA-E executes a funding agreement directly with the FFRDC/DOE Lab and a single, separate Cooperative Agreement with another entity on the Project Team. Notwithstanding the use of multiple agreements, the FFRDC/DOE Lab is the lead organization for the entire project, including all work performed by the FFRDC/DOE Lab and the rest of the Project Team.

When a FFRDC/DOE Lab is a *member* of a Project Team, ARPA-E executes a funding agreement directly with the FFRDC/DOE Lab and a single, separate Cooperative Agreement with the Prime Recipient, as the lead organization for the Project Team. Notwithstanding the use of multiple agreements, the Prime Recipient under the Cooperative Agreement is the lead organization for the entire project, including all work performed by the FFRDC/DOE Lab and the rest of the Project Team.

Funding agreements with DOE/NNSA FFRDCs take the form of Work Authorizations issued to DOE/NNSA FFRDCs through the DOE/NNSA Field Work Proposal system for work performed under Department of Energy Management & Operation Contracts. Funding agreements with non-DOE/NNSA FFRDCs, GOGOs (including NETL), and Federal instrumentalities (e.g., Tennessee Valley Authority) will be consistent with the sponsoring agreement between the U.S. Government and the Laboratory. Any funding agreement with an FFRDC or GOGO will have similar terms and conditions as ARPA-E's Model Cooperative Agreement (<https://arpa-e.energy.gov/technologies/project-guidance/pre-award-guidance/funding-agreements>).

Non-DOE GOGOs and Federal agencies may be proposed to provide support to the Project Team members on an applicant's project, through a Cooperative Research and Development Agreement (CRADA) or similar agreement.

3. OTHER TRANSACTIONS AUTHORITY

ARPA-E may use its "other transactions" authority under the America COMPETES Reauthorization Act of 2010 and DOE's other transactions authority as codified at 42 USC §7256 to enter into an other transaction agreement with Prime Recipients, on a case-by-case basis.

ARPA-E may negotiate an other transaction agreement when it determines that the use of a standard cooperative agreement, grant, or contract is not feasible or appropriate for a project.

The federal share of other transactions agreements should meet or exceed \$3,000,000. In general, an other transaction agreement normally requires a minimum cost share of 50%. See Section III.B.2 of the FOA.

D. STATEMENT OF SUBSTANTIAL INVOLVEMENT

ARPA-E is substantially involved in the direction of projects from inception to completion. For the purposes of an ARPA-E project, substantial involvement means:

Questions about this FOA? Check the Frequently Asked Questions available at <http://arpa-e.energy.gov/faq>. For questions that have not already been answered, email ARPA-E-CO@hq.doe.gov (with FOA name and number in subject line); see FOA Sec. VII.A. Problems with ARPA-E eXCHANGE? Email ExchangeHelp@hq.doe.gov (with FOA name and number in subject line).

- Project Teams must adhere to ARPA-E’s agency-specific and programmatic requirements.
- ARPA-E may intervene at any time in the conduct or performance of work under an award.
- ARPA-E does not limit its involvement to the administrative requirements of an award. Instead, ARPA-E has substantial involvement in the direction and redirection of the technical aspects of the project as a whole.
- ARPA-E may, at its sole discretion, modify or terminate projects that fail to achieve predetermined Go/No Go decision points or technical milestones and deliverables.
- During award negotiations, ARPA-E Program Directors and Prime Recipients mutually establish an aggressive schedule of quantitative milestones and deliverables that must be met every quarter. In addition, ARPA-E will negotiate and establish “Go/No-Go” milestones for each project. If the Prime Recipient fails to achieve any of the “Go/No-Go” milestones or technical milestones and deliverables as determined by the ARPA-E Contracting Officer, ARPA-E may – at its discretion - renegotiate the statement of project objectives or schedule of technical milestones and deliverables for the project. In the alternative, ARPA-E may suspend or terminate the award in accordance with 2 C.F.R. §§ 200.339 – 200.343.
- ARPA-E may provide guidance and/or assistance to the Prime Recipient to accelerate the commercialization of ARPA-E-funded technologies. Guidance and assistance provided by ARPA-E may include coordination with other Government agencies and nonprofits⁵⁶ to provide mentoring and networking opportunities for Prime Recipients. ARPA-E may also organize and sponsor events to educate Prime Recipients about key barriers to the commercialization of their ARPA-E-funded technologies. In addition, ARPA-E may establish collaborations with private and public entities to provide continued support for the development and commercialization of ARPA-E-funded technologies.

⁵⁶ The term “nonprofit organization” or “nonprofit” is defined in Section IX.

Questions about this FOA? Check the Frequently Asked Questions available at <http://arpa-e.energy.gov/faq>. For questions that have not already been answered, email ARPA-E-CO@hq.doe.gov (with FOA name and number in subject line); see FOA Sec. VII.A. Problems with ARPA-E eXCHANGE? Email ExchangeHelp@hq.doe.gov (with FOA name and number in subject line).

II. ELIGIBILITY INFORMATION

A. ELIGIBLE APPLICANTS

This FOA is open to U.S. universities, national laboratories, industry and individuals.

1. INDIVIDUALS

U.S. citizens or permanent residents may apply for funding in their individual capacity as a Standalone Applicant,⁵⁷ as the lead for a Project Team,⁵⁸ or as a member of a Project Team. However, ARPA-E will only award funding to an entity formed by the Applicant.

2. DOMESTIC ENTITIES

For-profit entities⁵⁹, educational institutions⁶⁰, and nonprofits⁶¹ that are incorporated in the United States, including U.S. territories, are eligible to apply for funding as a Standalone Applicant, as the lead organization for a Project Team, or as a member of a Project Team.

FFRDCs/DOE Labs are eligible to apply for funding as the lead organization for a Project Team or as a member of a Project Team that includes institutions of higher education, companies, research foundations, or trade and industry research collaborations, but not as a Standalone Applicant.

State, local, and tribal government entities are eligible to apply for funding as a member of a Project Team, but not as a Standalone Applicant or as the lead organization for a Project Team.

Federal agencies and instrumentalities (other than DOE) are eligible to apply for funding as a member of a Project Team, but not as a Standalone Applicant or as the lead organization for a Project Team.

3. FOREIGN ENTITIES

Foreign entities, whether for-profit or otherwise, are eligible to apply for funding as Standalone Applicants, as the lead organization for a Project Team, or as a member of a Project Team.

⁵⁷ A Standalone Applicant is an Applicant that applies for funding on its own, not as part of a Project Team.

⁵⁸ A Project Team consists of the Prime Recipient, Subrecipients, and others performing or otherwise supporting work under an ARPA-E funding agreement.

⁵⁹ For-Profit Organizations (Other than Small Businesses) (or *large businesses*): Means entities organized for-profit other than small businesses as defined elsewhere in this Glossary.

⁶⁰ Institutions of Higher Education (or educational institutions): Has the meaning set forth at 20 U.S.C. 1001.

⁶¹ Nonprofit organizations described in section 501(c)(4) of the Internal Revenue Code of 1986 that engaged in lobbying activities after December 31, 1995 are not eligible to apply for funding as a Prime Recipient or Subrecipient.

Foreign entities must designate in the Full Application a subsidiary or affiliate incorporated (or otherwise formed or to be formed) under the laws of a State or territory of the United States to receive funding. The Full Application must state the nature of the corporate relationship between the foreign entity and domestic subsidiary or affiliate. All work under the ARPA-E award must be performed in the United States. The Applicant may request a waiver of this requirement in the Business Assurances & Disclosures Form, which is submitted with the Full Application and can be found at <https://arpa-e-foa.energy.gov/> (see "View Template Application Documents"). Refer to the Business Assurances & Disclosures Form for guidance on the content and form of the request.

4. CONSORTIUM ENTITIES

Consortia, which may include domestic and foreign entities, must designate one member of the consortium as the consortium representative to the Project Team. The consortium representative must be incorporated in the United States. The eligibility of the consortium will be determined by reference to the eligibility of the consortium representative under Section III.A of the FOA. Each consortium must have an internal governance structure and a written set of internal rules. Upon request, the consortium entity must provide a written description of its internal governance structure and its internal rules to the Contracting Officer (ARPA-E-CO@hq.doe.gov).

Unincorporated consortia must provide the Contracting Officer with a collaboration agreement, commonly referred to as the articles of collaboration, which sets out the rights and responsibilities of each consortium member. This collaboration agreement binds the individual consortium members together and shall include the consortium's:

- Management structure;
- Method of making payments to consortium members;
- Means of ensuring and overseeing members' efforts on the project;
- Provisions for members' cost sharing contributions; and
- Provisions for ownership and rights in intellectual property developed previously or under the agreement.

B. COST SHARING⁶²

Applicants are bound by the cost share proposed in their Full Applications.

1. BASE COST SHARE REQUIREMENT

ARPA-E generally uses Cooperative Agreements to provide financial and other support to Prime Recipients (see Section II.C.1 of the FOA). Under a Cooperative Agreement or Grant, the Prime

⁶² Please refer to Section VI.B.3-4 of the FOA for guidance on cost share payments and reporting.

Recipient must provide at least 20% of the Total Project Cost⁶³ as cost share, except as provided in Sections III.B.2 or III.B.3 below.⁶⁴

2. INCREASED COST SHARE REQUIREMENT

Large businesses⁶⁵ are strongly encouraged to provide more than 20% of the Total Project Cost as cost share. ARPA-E may consider the amount of cost share proposed when selecting applications for award negotiations (see Section V.B.1 of the FOA).

Under an “other transaction” agreement, the Prime Recipient is normally expected to provide at least 50% of the Total Project Cost as cost share. ARPA-E may reduce this cost share requirement, as appropriate.

3. REDUCED COST SHARE REQUIREMENT

ARPA-E has reduced the base cost share requirement for the following types of projects:

- A domestic educational institution or domestic nonprofit applying as a Standalone Applicant is required to provide at least 5% of the Total Project Cost as cost share.
- Project Teams composed exclusively of domestic educational institutions, domestic nonprofits, and/or FFRDCs/DOE Labs/Federal agencies and instrumentalities (other than DOE) are required to provide at least 5% of the Total Project Cost as cost share. Small businesses – or consortia of small businesses – may provide 0% cost share from the outset of the project through the first 12 months of the project (hereinafter the “Cost Share Grace Period”).⁶⁶ If the project is continued beyond the Cost Share Grace Period, then at least 10% of the Total Project Cost (including the costs incurred during the Cost Share Grace Period) will be required as cost share over the remaining period of performance.
- Project Teams where a small business is the lead organization and small businesses perform greater than or equal to 80% of the total work under the funding agreement (as measured by the Total Project Cost) are entitled to the same cost share reduction and Cost Share Grace Period as provided above to Standalone small businesses or consortia of small businesses.

⁶³ The Total Project Cost is the sum of the Prime Recipient share and the Federal Government share of total allowable costs. The Federal Government share generally includes costs incurred by GOGOs and FFRDCs.

⁶⁴ Energy Policy Act of 2005, Pub.L. 109-58, sec. 988(c)

⁶⁵ The term “For-Profit Organizations (Other than Small Businesses)” or “large business” is defined in Section IX.

⁶⁶The term “small business” is defined in Section IX.

- Project Teams where domestic educational institutions, domestic nonprofits, small businesses, and/or FFRDCs perform greater than or equal to 80% of the total work under the funding agreement (as measured by the Total Project Cost) are required to provide at least 10% of the Total Project Cost as cost share. However, any entity (such as a large business) receiving patent rights under a class waiver, or other patent waiver, that is part of a Project Team receiving this reduction must continue to meet the statutory minimum cost share requirement (20%) for its portion of the Total Project Cost.
- Projects that do not meet any of the above criteria are subject to the base cost share requirements described in Sections III.B.1 and III.B.2 of the FOA.

4. LEGAL RESPONSIBILITY

Although the cost share requirement applies to the Project Team as a whole, the funding agreement makes the Prime Recipient legally responsible for paying, or ensuring payment of the entire cost share. The Prime Recipient's cost share obligation is expressed in the funding agreement as a static amount in U.S. dollars (cost share amount) and as a percentage of the Total Project Cost (cost share percentage). If the funding agreement is terminated prior to the end of the period of performance, the Prime Recipient is required to contribute at least the cost share percentage of total expenditures incurred through the date of termination.

The Prime Recipient is solely responsible for managing cost share contributions by the Project Team and enforcing cost share obligations assumed by Project Team members in subawards or related agreements.

5. COST SHARE ALLOCATION

Each Project Team is free to determine how much each Project Team member will contribute towards the cost share requirement. The amount contributed by individual Project Team members may vary, as long as the cost share requirement for the project as a whole is met.

6. COST SHARE TYPES AND ALLOWABILITY

Every cost share contribution must be allowable under the applicable Federal cost principles, as described in Section IV.G of the FOA.

Project Teams may provide cost share in the form of cash or in-kind contributions. Cash contributions may be provided by the Prime Recipient or Subrecipients. Allowable in-kind contributions include but are not limited to personnel costs, indirect costs, facilities and administrative costs, rental value of buildings or equipment, and the value of a service, other resource, or third party in-kind contribution. Project Teams may use funding or property received from state or local governments to meet the cost share requirement, so long as the

funding or property was not provided to the state or local government by the Federal Government.

The Prime Recipient may not use the following sources to meet its cost share obligations:

- Revenues or royalties from the prospective operation of an activity beyond the period of performance;
- Proceeds from the prospective sale of an asset of an activity;
- Appropriated Federal funding or property (e.g., Federal grants, equipment owned by the Federal Government); or
- Expenditures that were reimbursed under a separate Federal program.

In addition, Project Teams may not use independent research and development (IR&D) funds⁶⁷ to meet their cost share obligations under Cooperative Agreements. However, Project Teams may use IR&D funds to meet their cost share obligations under “other transaction” agreements.

Project Teams may not use the same cash or in-kind contributions to meet cost share requirements for more than one project or program.

Cost share contributions must be specified in the project budget, verifiable from the Prime Recipient’s records, and necessary and reasonable for proper and efficient accomplishment of the project. Every cost share contribution must be reviewed and approved in advance by the Contracting Officer and incorporated into the project budget before the expenditures are incurred.

Applicants may wish to refer to 2 C.F.R. Parts 200 and 910, and 10 C.F.R Part 603 for additional guidance on cost sharing, specifically 2 C.F.R. §§ 200.306 and 910.130, and 10 C.F.R. §§ 603.525-555.

7. COST SHARE CONTRIBUTIONS BY FFRDCs AND GOGOS

Because FFRDCs are funded by the Federal Government, costs incurred by FFRDCs generally may not be used to meet the cost share requirement. FFRDCs may contribute cost share only if the contributions are paid directly from the contractor’s Management Fee or a non-Federal source.

Because GOGOs/Federal Agencies are funded by the Federal Government, GOGOs/Federal Agencies may not provide cost share for the proposed project. However, the GOGO/Agency costs would be included in Total Project Costs for purposes of calculating the cost-sharing requirements of the applicant.

⁶⁷ As defined in Federal Acquisition Regulation SubSection 31.205-18.

8. COST SHARE VERIFICATION

Upon selection for award negotiations, Applicants are required to provide information and documentation regarding their cost share contributions. Please refer to Section VI.B.3 of the FOA for guidance on the requisite cost share information and documentation.

C. OTHER

1. COMPLIANT CRITERIA

Concept Papers are deemed compliant if:

- The Applicant meets the eligibility requirements in Section III.A of the FOA;
- The Concept Paper complies with the content and form requirements in Section IV.C of the FOA; and
- The Applicant entered all required information, successfully uploaded all required documents, and clicked the “Submit” button in ARPA-E eXCHANGE by the deadline stated in the FOA.

Concept Papers found to be noncompliant may not be merit reviewed or considered for award. ARPA-E may not review or consider noncompliant Concept Papers, including Concept Papers submitted through other means, Concept Papers submitted after the applicable deadline, and incomplete Concept Papers. A Concept Paper is incomplete if it does not include required information. ARPA-E will not extend the submission deadline for Applicants that fail to submit required information and documents due to server/connection congestion.

Full Applications are deemed compliant if:

- The Applicant submitted a compliant and responsive Concept Paper;
- The Applicant meets the eligibility requirements in Section III.A of the FOA;
- The Full Application complies with the content and form requirements in Section IV.D of the FOA; and
- The Applicant entered all required information, successfully uploaded all required documents, and clicked the “Submit” button in ARPA-E eXCHANGE by the deadline stated in the FOA.

Full Applications found to be noncompliant may not be merit reviewed or considered for award. ARPA-E may not review or consider noncompliant Full Applications, including Full Applications submitted through other means, Full Applications submitted after the applicable deadline, and incomplete Full Applications. A Full Application is incomplete if it does not include required information and documents, such as Forms SF-424 and SF-424A. ARPA-E will not extend the submission deadline for Applicants that fail to submit required information and documents due to server/connection congestion.

Replies to Reviewer Comments are deemed compliant if:

Questions about this FOA? Check the Frequently Asked Questions available at <http://arpa-e.energy.gov/faq>. For questions that have not already been answered, email ARPA-E-CO@hq.doe.gov (with FOA name and number in subject line); see FOA Sec. VII.A. Problems with ARPA-E eXCHANGE? Email ExchangeHelp@hq.doe.gov (with FOA name and number in subject line).

- The Applicant successfully uploads its response to ARPA-E eXCHANGE by the deadline stated in the FOA; and
- The Replies to Reviewer Comments comply with the content and form requirements of Section IV.E of the FOA.

ARPA-E will not review or consider noncompliant Replies to Reviewer Comments, including Replies submitted through other means and Replies submitted after the applicable deadline. ARPA-E will not extend the submission deadline for Applicants that fail to submit required information due to server/connection congestion. ARPA-E will review and consider each compliant and responsive Full Application, even if no Reply is submitted or if the Reply is found to be noncompliant.

2. RESPONSIVENESS CRITERIA

ARPA-E performs a preliminary technical review of Concept Papers and Full Applications. The following types of submissions may be deemed nonresponsive and may not be reviewed or considered:

- Submissions that fall outside the technical parameters specified in this FOA.
- Submissions that have been submitted in response to currently issued ARPA-E FOAs.
- Submissions that are not scientifically distinct from applications submitted in response to currently issued ARPA-E FOAs.
- Submissions for basic research aimed solely at discovery and/or fundamental knowledge generation.
- Submissions for large-scale demonstration projects of existing technologies.
- Submissions for proposed technologies that represent incremental improvements to existing technologies.
- Submissions for proposed technologies that are not based on sound scientific principles (e.g., violates a law of thermodynamics).
- Submissions for proposed technologies that are not transformational, as described in Section I.A of the FOA.
- Submissions for proposed technologies that do not have the potential to become disruptive in nature, as described in Section I.A of the FOA. Technologies must be scalable such that they could be disruptive with sufficient technical progress.
- Submissions that are not distinct in scientific approach or objective from activities currently supported by or actively under consideration for funding by any other office within Department of Energy.
- Submissions that are not distinct in scientific approach or objective from activities currently supported by or actively under consideration for funding by other government agencies or the private sector.
- Submissions that do not propose a R&D plan that allows ARPA-E to evaluate the submission under the applicable merit review criteria provided in Section V.A of the FOA.

Questions about this FOA? Check the Frequently Asked Questions available at <http://arpa-e.energy.gov/faq>. For questions that have not already been answered, email ARPA-E-CO@hq.doe.gov (with FOA name and number in subject line); see FOA Sec. VII.A. Problems with ARPA-E eXCHANGE? Email ExchangeHelp@hq.doe.gov (with FOA name and number in subject line).

3. SUBMISSIONS SPECIFICALLY NOT OF INTEREST

Submissions that propose the following will be deemed nonresponsive and will not be merit reviewed or considered:

- System-level control schemes and algorithms that do not include advances in device/module technologies of interest to this FOA
- Material advances that do not result in a passive component, package, device and/or module (i.e., pure material studies that do not progress to the next level of integration)
- Strictly software/algorithm development

4. LIMITATION ON NUMBER OF SUBMISSIONS

ARPA-E is not limiting the number of submissions from Applicants. Applicants may submit more than one application to this FOA, provided that each application is scientifically distinct.

Small business Applicants that qualify as a “Small Business Concern”⁶⁸ may apply to only one of the two ARPA-E ULTRAFAST FOAs: DE-FOA-0002999 (ULTRAFAST SBIR/STTR), or DE-FOA-0002998 (ULTRAFAST). Small businesses that qualify as “Small Business Concerns” are strongly encouraged to apply under the former (SBIR/STTR FOA). To determine eligibility as a “Small Business Concern” under DE-FOA-0002999 (SBIR/STTR), please review the eligibility requirements in Sections III.A – III.D of that FOA.

⁶⁸ Please refer to the U.S. Small Business Administration (SBA) website. A Small Business Concern is a for-profit entity that: (1) maintains a place of business located in the United States; (2) operates primarily within the United States or makes a significant contribution to the United States economy through payment of taxes or use of American products, materials or labor; (3) is an individual proprietorship, partnership, corporation, limited liability company, joint venture, association, trust, or cooperative; and (4) meets the size eligibility requirements set forth in 13 C.F.R. § 121.702. Where the entity is formed as a joint venture, there can be no more than 49% participation by foreign business entities in the joint venture.

Questions about this FOA? Check the Frequently Asked Questions available at <http://arpa-e.energy.gov/faq>. For questions that have not already been answered, email ARPA-E-CO@hq.doe.gov (with FOA name and number in subject line); see FOA Sec. VII.A. Problems with ARPA-E eXCHANGE? Email ExchangeHelp@hq.doe.gov (with FOA name and number in subject line).

III. APPLICATION AND SUBMISSION INFORMATION

A. APPLICATION PROCESS OVERVIEW

1. REGISTRATION IN ARPA-E eXCHANGE

The first step in applying to this FOA is registration in ARPA-E eXCHANGE, ARPA-E's online application portal. For detailed guidance on using ARPA-E eXCHANGE, please refer to Section IV.H.1 of the FOA and the "ARPA-E eXCHANGE User Guide" (<https://arpa-e-foa.energy.gov/Manuals.aspx>).

2. CONCEPT PAPERS

Applicants must submit a Concept Paper by the deadline stated in the FOA. Section IV.C of the FOA provides instructions on submitting a Concept Paper.

ARPA-E performs a preliminary review of Concept Papers to determine whether they are compliant and responsive, as described in Section III.C of the FOA. Concept Papers found to be noncompliant or nonresponsive may not be merit reviewed or considered for award. ARPA-E makes an independent assessment of each compliant and responsive Concept Paper based on the criteria and program policy factors in Sections V.A.1 and V.B.1 of the FOA.

ARPA-E will encourage a subset of Applicants to submit Full Applications. Other Applicants will be discouraged from submitting a Full Application in order to save them the time and expense of preparing an application submission that is unlikely to be selected for award negotiations. By discouraging the submission of a Full Application, ARPA-E intends to convey its lack of programmatic interest in the proposed project. Such assessments do not necessarily reflect judgments on the merits of the proposed project. Unsuccessful Applicants should continue to submit innovative ideas and concepts to future FOAs.

3. FULL APPLICATIONS

Applicants must submit a Full Application by the deadline stated in the FOA. Applicants will have approximately 45 days from receipt of the Encourage/Discourage notification to prepare and submit a Full Application. Section IV.D of the FOA provides instructions on submitting a Full Application.

ARPA-E performs a preliminary review of Full Applications to determine whether they are compliant and responsive, as described in Section III.C of the FOA. Full Applications found to be noncompliant or nonresponsive may not be merit reviewed or considered for award. ARPA-E makes an independent assessment of each compliant and responsive Full Application based on the criteria and program policy factors in Sections V.A.2 and V.B.1 of the FOA.

Questions about this FOA? Check the Frequently Asked Questions available at <http://arpa-e.energy.gov/faq>. For questions that have not already been answered, email ARPA-E-CO@hq.doe.gov (with FOA name and number in subject line); see FOA Sec. VII.A. Problems with ARPA-E eXCHANGE? Email ExchangeHelp@hq.doe.gov (with FOA name and number in subject line).

4. REPLY TO REVIEWER COMMENTS

Once ARPA-E has completed its review of Full Applications, reviewer comments on compliant and responsive Full Applications are made available to Applicants via ARPA-E eXCHANGE. Applicants may submit an optional Reply to Reviewer Comments, which must be submitted by the deadline stated in the FOA. Section IV.E of the FOA provides instructions on submitting a Reply to Reviewer Comments.

ARPA-E performs a preliminary review of Replies to determine whether they are compliant, as described in Section III.C.1 of the FOA. ARPA-E will review and consider compliant Replies only. ARPA-E will review and consider each compliant and responsive Full Application, even if no Reply is submitted or if the Reply is found to be non-compliant.

5. PRE-SELECTION CLARIFICATIONS AND “DOWN-SELECT” PROCESS

Once ARPA-E completes its review of Full Applications and Replies to Reviewer Comments, it may, at the Contracting Officer’s discretion, conduct a pre-selection clarification process and/or perform a “down-select” of Full Applications. Through the pre-selection clarification process or down-select process, ARPA-E may obtain additional information from select Applicants through pre-selection meetings, webinars, videoconferences, conference calls, written correspondence, or site visits that can be used to make a final selection determination. ARPA-E will not reimburse Applicants for travel and other expenses relating to pre-selection meetings or site visits, nor will these costs be eligible for reimbursement as pre-award costs.

ARPA-E may select applications for award negotiations and make awards without pre-selection meetings and site visits. Participation in a pre-selection meeting or site visit with ARPA-E does not signify that Applicants have been selected for award negotiations.

6. SELECTION FOR AWARD NEGOTIATIONS

ARPA-E carefully considers all of the information obtained through the application process and makes an independent assessment of each compliant and responsive Full Application based on the criteria and program policy factors in Sections V.A.2 and V.B.1 of the FOA. The Selection Official may select all or part of a Full Application for award negotiations. The Selection Official may also postpone a final selection determination on one or more Full Applications until a later date, subject to availability of funds and other factors. ARPA-E will enter into award negotiations only with selected Applicants.

Applicants are promptly notified of ARPA-E’s selection determination. ARPA-E may stagger its selection determinations. As a result, some Applicants may receive their notification letter in advance of other Applicants. Please refer to Section VI.A of the FOA for guidance on award notifications.

Questions about this FOA? Check the Frequently Asked Questions available at <http://arpa-e.energy.gov/faq>. For questions that have not already been answered, email ARPA-E-CO@hq.doe.gov (with FOA name and number in subject line); see FOA Sec. VII.A. Problems with ARPA-E eXCHANGE? Email ExchangeHelp@hq.doe.gov (with FOA name and number in subject line).

B. APPLICATION FORMS

Required forms for Full Applications are available on ARPA-E eXCHANGE (<https://arpa-e-foa.energy.gov>), including the SF-424 and Budget Justification Workbook/SF-424A. A sample Summary Slide is available on ARPA-E eXCHANGE. Applicants may use the templates available on ARPA-E eXCHANGE, including the template for the Concept Paper, the template for the Technical Volume of the Full Application, the template for the Summary Slide, the template for the Summary for Public Release, the template for the Reply to Reviewer Comments, and the template for the Business Assurances & Disclosures Form. A sample response to the Business Assurances & Disclosures Form is available on ARPA-E eXCHANGE.

C. CONTENT AND FORM OF CONCEPT PAPERS

The Concept Paper is mandatory (i.e. in order to submit a Full Application, a compliant and responsive Concept Paper must have been submitted) and must conform to the following formatting requirements:

- The Concept Paper must not exceed 4 pages in length including graphics, figures, and/or tables.
- The Concept Paper must be submitted in Adobe PDF format.
- The Concept Paper must be written in English.
- All pages must be formatted to fit on 8-1/2 by 11 inch paper with margins not less than one inch on every side. Single space all text and use Times New Roman typeface, a black font color, and a font size of 12 point or larger (except in figures and tables).
- The ARPA-E assigned Control Number, the Lead Organization Name, and the Principal Investigator's Last Name must be prominently displayed on the upper right corner of the header of every page. Page numbers must be included in the footer of every page.
- The first paragraph must include the Lead Organization's Name and Location, Principal Investigator's Name, Technical Category, Proposed Funding Requested (Federal and Cost Share), and Project Duration.

Concept Papers found to be noncompliant or nonresponsive may not be merit reviewed or considered for award (see Section III.C of the FOA).

Each Concept Paper must be limited to a single concept or technology. Unrelated concepts and technologies must not be consolidated into a single Concept Paper.

A fillable Concept Paper template is available on ARPA-E eXCHANGE at <https://arpa-e-foa.energy.gov>.

Concept Papers must conform to the content requirements described below. If Applicants exceed the maximum page length indicated above, ARPA-E will review only the authorized number of pages and disregard any additional pages.

1. CONCEPT PAPER

a. CONCEPT SUMMARY

- Describe the proposed concept with minimal jargon, and explain how it addresses the Program Objectives of the FOA.

b. INNOVATION AND IMPACT

- Clearly identify the problem to be solved with the proposed technology concept.
- Describe how the proposed effort represents an innovative and potentially transformational solution to the technical challenges posed by the FOA.
- Explain the concept's potential to be disruptive compared to existing or emerging technologies.
- To the extent possible, provide quantitative metrics in a table that compares the proposed technology concept to current and emerging technologies and to the Technical Performance Targets in Section I.E of the FOA for the appropriate Technology Category in Section I.D of the FOA.

c. PROPOSED WORK

- Describe the final deliverable(s) for the project and the overall technical approach used to achieve project objectives.
- Discuss alternative approaches considered, if any, and why the proposed approach is most appropriate for the project objectives.
- Describe the background, theory, simulation, modeling, experimental data, or other sound engineering and scientific practices or principles that support the proposed approach. Provide specific examples of supporting data and/or appropriate citations to the scientific and technical literature.
- Describe why the proposed effort is a significant technical challenge and the key technical risks to the project. Does the approach require one or more entirely new technical developments to succeed? How will technical risk be mitigated?
- Identify techno-economic challenges to be overcome for the proposed technology to be commercially relevant.
- Estimated federal funds requested; total project cost including cost sharing.

d. TEAM ORGANIZATION AND CAPABILITIES

- Indicate the roles and responsibilities of the organizations and key personnel that comprise the Project Team.
- Provide the name, position, and institution of each key team member and describe in 1-2 sentences the skills and experience that he/she brings to the team.
- Identify key capabilities provided by the organizations comprising the Project Team and how those key capabilities will be used in the proposed effort.
- Identify (if applicable) previous collaborative efforts among team members relevant to the proposed effort.

D. CONTENT AND FORM OF FULL APPLICATIONS

Full Applications must conform to the following formatting requirements:

- Each document must be submitted in the file format prescribed below.
- The Full Application must be written in English.
- All pages must be formatted to fit on 8-1/2 by 11 inch paper with margins not less than one inch on every side. Single space all text and use Times New Roman typeface, a black font color, and a font size of 12 point or larger (except in figures and tables).
- The ARPA-E assigned Control Number, the Lead Organization Name, and the Principal Investigator’s Last Name must be prominently displayed on the upper right corner of the header of every page. Page numbers must be included in the footer of every page.

Full Applications found to be noncompliant or nonresponsive may not be merit reviewed or considered for award (see Section III.C of the FOA).

Each Full Application should be limited to a single concept or technology. Unrelated concepts and technologies should not be consolidated in a single Full Application.

Fillable Full Application template documents are available on ARPA-E eXCHANGE at <https://arpa-e-foa.energy.gov>.

Full Applications must conform to the content requirements described below.

Component	Required Format	Description and Information
Technical Volume	PDF	The technical volume is the centerpiece of the Full Application. Applicants must provide a detailed description of the proposed R&D project and Project Team.
SF-424	PDF	Application for Federal Assistance. Applicants are responsible for ensuring that the proposed costs listed in eXCHANGE match those listed on forms SF-424 and

Questions about this FOA? Check the Frequently Asked Questions available at <http://arpa-e.energy.gov/faq>. For questions that have not already been answered, email ARPA-E-CO@hq.doe.gov (with FOA name and number in subject line); see FOA Sec. VII.A. Problems with ARPA-E eXCHANGE? Email ExchangeHelp@hq.doe.gov (with FOA name and number in subject line).

		SF-424A. Inconsistent submissions may impact ARPA-E’s final award determination.
Budget Justification Workbook/SF-424A	XLS	Budget Information – Non-Construction Programs
Summary for Public Release	PDF	Short summary of the proposed R&D project. Intended for public release.
Summary Slide	PPT	A four-panel project slide summarizing different aspects of the proposed R&D project.
Business Assurances & Disclosures Form	PDF	Applicants should provide comprehensive responses to the questions on this form. Requires the Applicant to make responsibility disclosures and disclose conflicts of interest within the Project Team. Requires the Applicant to describe the additionality and risks associated with the proposed project, disclose applications for funding currently pending with Federal and non-Federal entities, and disclose funding from Federal and non-Federal entities for work in the same technology area as the proposed R&D project. If an Applicant Team member is an FFRDC/DOE Lab, that entity must provide written authorization from the cognizant Federal agency and, if a DOE/NNSA FFRDC/DOE Lab, a Field Work Proposal. This form allows the Applicant to request a waiver or modification of the Performance of Work in the United States requirement. This form requires the Applicant to submit a Disclosure of Foreign Relationships. A sample response to the Business Assurances & Disclosures Form is also available on ARPA-E eXCHANGE.

ARPA-E provides detailed guidance on the content and form of each component below.

1. FIRST COMPONENT: TECHNICAL VOLUME

The Technical Volume must be submitted in Adobe PDF format. A Technical Volume template is available at <https://arpa-e-foa.energy.gov>. The Technical Volume must conform to the content and form requirements included within the template, including maximum page lengths. If Applicants exceed the maximum page lengths specified for each section, or add any additional sections not requested, ARPA-E may review only the authorized number of pages and disregard any additional pages or sections, or ARPA-E may determine that the submission as a whole is noncompliant per Section III.C of the FOA.

Applicants must provide sufficient citations and references to the primary research literature to justify the claims and approaches made in the Technical Volume. ARPA-E and reviewers may review primary research literature in order to evaluate applications. However, all relevant technical information should be included in the body of the Technical Volume.

2. SECOND COMPONENT: SF-424

Questions about this FOA? Check the Frequently Asked Questions available at <http://arpa-e.energy.gov/faq>. For questions that have not already been answered, email ARPA-E-CO@hq.doe.gov (with FOA name and number in subject line); see FOA Sec. VII.A. Problems with ARPA-E eXCHANGE? Email ExchangeHelp@hq.doe.gov (with FOA name and number in subject line).

The SF-424 must be submitted in Adobe PDF format. This form is available on ARPA-E eXCHANGE at <https://arpa-e-foa.energy.gov>.

The SF-424 includes instructions for completing the form. Applicants must complete all required fields in accordance with the instructions. Applicants may identify and include in Block 14 the entities, their addresses, and corresponding census tract numbers for any project activities that will occur within any designated Qualified Opportunity Zone (QOZ). To locate Qualified Opportunity Zones go to: <https://www.cdfifund.gov/opportunity-zones>.

Prime Recipients and Subrecipients are required to complete SF-LLL (Disclosure of Lobbying Activities), available at <https://www.grants.gov/forms/post-award-reporting-forms.html>, if any non-Federal funds have been paid or will be paid to any person for influencing or attempting to influence an officer or employee of any Federal agency, a Member of Congress, an officer or employee of Congress, or an employee of a Member of Congress in connection with your application or funding agreement. The completed SF-LLL must be appended to the SF-424.

ARPA-E provides the following supplemental guidance on completing the SF-424:

- Each Project Team should submit only one SF-424 (i.e., a Subrecipient should not submit a separate SF-424).
- The list of certifications and assurances in Block 21 can be found at <http://energy.gov/management/downloads/certifications-and-assurances-use-sf-424>.
- The dates and dollar amounts on the SF-424 are for the entire period of performance (from the project start date to the project end date), not a portion thereof.
- Applicants are responsible for ensuring that the proposed costs listed in eXCHANGE match those listed on forms SF-424 and SF-424A. Inconsistent submissions may impact ARPA-E's final award determination.

3. THIRD COMPONENT: BUDGET JUSTIFICATION WORKBOOK/SF-424A

Applicants are required to complete the Budget Justification Workbook/SF-424A Excel spreadsheet. This form is available on ARPA-E eXCHANGE at <https://arpa-e-foa.energy.gov>. Prime Recipients must complete each tab of the Budget Justification Workbook for the project as a whole, including all work to be performed by the Prime Recipient and its Subrecipients and Contractors. The SF-424A form included with the Budget Justification Workbook will "auto-populate" as the Applicant enters information into the Workbook. Applicants should carefully read the "Instructions and Summary" tab provided within the Budget Justification Workbook. Subrecipient information must be submitted as follows:

- Each Subrecipient incurring greater than or equal to 10% of the Total Project Cost must complete a separate Budget Justification workbook to justify its proposed budget. These worksheets must be inserted as additional sheets within in the Prime Recipient's Budget Justification.
- Subrecipients incurring less than 10% of the Total Project Cost are not required to complete a separate Budget Justification workbook. However, such Subrecipients are required to provide supporting documentation to justify their proposed budgets. At a minimum, the supporting documentation must show which tasks/subtasks are being performed, the purpose/need for the effort, and a sufficient basis for the estimated costs.

ARPA-E provides the following supplemental guidance on completing the Budget Justification Workbook/SF-424A:

- Applicants may request funds under the appropriate object class category tabs as long as the item and amount requested are necessary to perform the proposed work, meet all the criteria for allowability under the applicable Federal cost principles, and are not prohibited by the funding restrictions described herein.
- If Patent costs are requested, they must be included in the Applicant's proposed budget (see Section IV.G.3 of the FOA for more information on Patent Costs).
- Unless a waiver is granted by ARPA-E, each Project Team must spend at least 5% of the Federal funding (i.e., the portion of the award that does not include the recipient's cost share) on Technology Transfer & Outreach (TT&O) activities to promote and further the development and eventual deployment of ARPA-E-funded technologies.
- All TT&O costs requested must be included in the Applicant's proposed budget and identified as TT&O costs in the Budget Justification Workbook/SF-424A with the costs being requested under the "Other" budget category. All budgeted activities must relate to achieving specific objectives, technical milestones and deliverables outlined in Section 2.4 Task Descriptions of the Technical Volume.
- For more information, please refer to the ARPA-E Budget Justification Guidance document at <https://arpa-e-foa.energy.gov>.

4. FOURTH COMPONENT: SUMMARY FOR PUBLIC RELEASE

Applicants are required to provide a 250 word maximum Summary for Public Release. A Summary for Public Release template is available on ARPA-E eXCHANGE (<https://arpa-e-foa.energy.gov>). The Summary for Public Release must be submitted in Adobe PDF format. This summary should not include any confidential, proprietary, or privileged information. The summary should be written for a lay audience (e.g., general public, media, Congress) using plain English.

250 Words	SUMMARY FOR PUBLIC RELEASE	Briefly describe the proposed effort, summarize its objective(s) and technical approach, describe its ability to achieve the “Program Objectives” (see Section I.C of the FOA), and indicate its potential impact on “ARPA-E Mission Areas” (see Section I.A of the FOA). The summary should be written at technical level suitable for a high-school science student and is designed for public release. INSTRUCTIONS: (1) The Summary for Public Release shall not exceed 250 words and one paragraph. (2) The Summary for Public Release shall consist only of text—no graphics, figures, or tables. (3) For applications selected for award negotiations, the Summary may be used as the basis for a public announcement by ARPA-E; therefore, this Cover Page and Summary should not contain confidential or proprietary information. See Section VIII.I of the FOA for additional information on marking confidential information
------------------	-----------------------------------	---

5. FIFTH COMPONENT: SUMMARY SLIDE

Applicants are required to provide a single PowerPoint slide summarizing the proposed project. The slide must be submitted in Microsoft PowerPoint format. This slide will be used during ARPA-E’s evaluation of Full Applications. A summary slide template and a sample summary slide are available on ARPA-E eXCHANGE (<https://arpa-e-foa.energy.gov>). Summary Slides must conform to the content requirements described below:

- A Technology Summary;
 - Bullet points that describe novel aspects of the proposed technology and technology approach;
- A description of the technology’s impact;
 - Quantitative description (through text or graphic) of the impact the proposed project will provide to the market and ARPA-E mission areas;
- Proposed Targets;
 - Including any important technical performance metrics and/or impact categories;
 - Including quantitative description of the state of the art;
 - Including quantitative descriptions of the proposed targets;
- Any key graphics (illustrations, charts and/or tables) summarizing technology development and/or impact;
- The project’s key idea/takeaway;
- Project title and Principal Investigator information; and
- Requested ARPA-E funds and proposed Applicant cost share.

Questions about this FOA? Check the Frequently Asked Questions available at <http://arpa-e.energy.gov/faq>. For questions that have not already been answered, email ARPA-E-CO@hq.doe.gov (with FOA name and number in subject line); see FOA Sec. VII.A. Problems with ARPA-E eXCHANGE? Email ExchangeHelp@hq.doe.gov (with FOA name and number in subject line).

6. SIXTH COMPONENT: BUSINESS ASSURANCES & DISCLOSURES FORM

Applicants are required to provide the information requested in the Business Assurances & Disclosures Form. The information must be submitted in Adobe PDF format. A fillable Business Assurances & Disclosures Form template is available on ARPA-E eXCHANGE at <https://arpa-e-foa.energy.gov>. A sample response to the Business Assurances & Disclosures Form is also available on ARPA-E eXCHANGE.

As described in the Business Assurances & Disclosures Form, the Applicant is required to:

- Disclose conditions bearing on responsibility, such as criminal convictions and Federal tax liability;
- Disclose conflicts of interest within the Project Team and provide the Applicant's up-to-date, written, and enforced conflict of interest policy in accordance with DOE Interim COI Policy guidance at <https://www.energy.gov/management/financial-assistance-letter-no-fal-2022-02>;
- If the Applicant is a FFRDC/DOE Lab, submit written authorization from the cognizant Federal agency; and
- If the Applicant is a DOE/NNSA FFRDC/DOE Lab, submit a Field Work Proposal; and
- Submit a Disclosure of Foreign Relationships.

In addition, ARPA-E is required by statute to "accelerat[e] transformational technological advances in areas that industry is by itself not likely to undertake because of technical and financial uncertainty."⁶⁹ In accordance with ARPA-E's statutory mandate, the Applicant is required to:

- Describe the additionality and risks associated with the proposed R&D project;
- Disclose any applications for the same project or related work currently pending with any Federal or non-Federal entities; and
- Disclose all funding for work in the same technology area as the proposed project received from any Federal or non-Federal entity within the last 5 years.

Finally, the Applicant may use the Business Assurances & Disclosures Form to:

- Request authorization to perform some work **overseas** outside of the United States; and
- Request a waiver of the TT&O spending requirement.

E. CONTENT AND FORM OF REPLIES TO REVIEWER COMMENTS

Written feedback on Full Applications is made available to Applicants before the submission

⁶⁹ America COMPETES Act, Pub. L. No. 110-69, § 5012 (2007), as amended (codified at 42 U.S.C. § 16538).

deadline for Replies to Reviewer Comments. Applicants have a brief opportunity to prepare a short Reply to Reviewer Comments responding to one or more comments or supplementing their Full Application. A fillable Reply to Reviewer Comments template is available on ARPA-E eXCHANGE (<https://arpa-e-foa.energy.gov>).

Replies to Reviewer Comments must conform to the following requirements:

- The Reply to Reviewer Comments must be submitted in Adobe PDF format.
- The Reply to Reviewer Comments must be written in English.
- All pages must be formatted to fit on 8-1/2 by 11 inch paper with margins not less than one inch on every side. Use Times New Roman typeface, a black font color, and a font size of 12 points or larger (except in figures and tables).
- The Control Number must be prominently displayed on the upper right corner of the header of every page. Page numbers must be included in the footer of every page.

ARPA-E may not review or consider noncompliant Replies to Reviewer Comments (see Section III.C.1 of the FOA). ARPA-E will review and consider each compliant and responsive Full Application, even if no Reply is submitted or if the Reply is found to be noncompliant.

Replies to Reviewer Comments must conform to the following content and form requirements, including maximum page lengths, described below. If a Reply to Reviewer Comments is more than three pages in length, ARPA-E may review only the first three pages and disregard any additional pages, or ARPA-E may determine that the submission as a whole is noncompliant.

SECTION	PAGE LIMIT	DESCRIPTION
Text	2 pages maximum	<ul style="list-style-type: none">• Applicants may respond to one or more reviewer comments or supplement their Full Application.
Images	1 page maximum	<ul style="list-style-type: none">• Applicants may provide graphs, charts, or other data to respond to reviewer comments or supplement their Full Application.

F. INTERGOVERNMENTAL REVIEW

This program is not subject to Executive Order 12372 (Intergovernmental Review of Federal Programs).

G. FUNDING RESTRICTIONS

1. ALLOWABLE COSTS

All expenditures must be allowable, allocable, and reasonable in accordance with the applicable Federal cost principles. Pursuant to 2 C.F.R. § 910.352, the cost principles in the Federal Acquisition Regulations (48 C.F.R. Part 31.2) apply to for-profit entities. The cost principles

Questions about this FOA? Check the Frequently Asked Questions available at <http://arpa-e.energy.gov/faq>. For questions that have not already been answered, email ARPA-E-CO@hq.doe.gov (with FOA name and number in subject line); see FOA Sec. VII.A. Problems with ARPA-E eXCHANGE? Email ExchangeHelp@hq.doe.gov (with FOA name and number in subject line).

contained in 2 C.F.R. Part 200, Subpart E apply to all entities other than for-profits.

2. PRE-AWARD COSTS

ARPA-E will not reimburse any pre-award costs incurred by Applicants before they are selected for award negotiations. Please refer to Section VI.A of the FOA for guidance on award notices.

Upon selection for award negotiations, Applicants may incur pre-award costs at their own risk, consistent with the requirements in 2 C.F.R. Part 200, as modified by 2 C.F.R. Part 910, and other Federal laws and regulations. All submitted budgets are subject to change and are typically reworked during award negotiations. ARPA-E is under no obligation to reimburse pre-award costs if, for any reason, the Applicant does not receive an award or the award is made for a lesser amount than the Applicant expected, or if the costs incurred are not allowable, allocable, or reasonable.

3. PATENT COSTS

For Subject Inventions disclosed to DOE under an award, ARPA-E will reimburse the Prime Recipient – in addition to allowable costs associated with Subject Invention disclosures - up to \$30,000 of expenditures for filing and prosecution of United States patent applications, including international applications (PCT application) submitted to the United States Patent and Trademark Office (USPTO).

The Prime Recipient may request a waiver of the \$30,000 cap. Note that, patent costs are considered to be Technology Transfer & Outreach (TT&O) costs (see Section IV.G.8 of the FOA below), and should be requested as such.

4. CONSTRUCTION

ARPA-E generally does not fund projects that involve major construction. Recipients are required to obtain written authorization from the Contracting Officer before incurring any major construction costs.

5. FOREIGN TRAVEL

ARPA-E generally does not fund projects that involve foreign travel. Recipients are required to obtain written authorization from the ARPA-E Program Director before incurring any foreign travel costs and provide trip reports with their reimbursement requests.

6. PERFORMANCE OF WORK IN THE UNITED STATES

ARPA-E strongly encourages interdisciplinary and cross-sectoral collaboration spanning organizational boundaries. Such collaboration enables the achievement of scientific and technological outcomes that were previously viewed as extremely difficult, if not impossible.

ARPA-E requires all work under ARPA-E funding agreements to be performed in the United States. However, Applicants may request a waiver of this requirement where their project would materially benefit from, or otherwise requires, certain work to be performed overseas.

Applicants seeking a waiver of this requirement are required to include an explicit request in the Business Assurances & Disclosures Form, which is part of the Full Application submitted to ARPA-E. Such waivers are granted where there is a demonstrated need, as determined by ARPA-E.

7. PURCHASE OF NEW EQUIPMENT

All equipment purchased under ARPA-E funding agreements must be made or manufactured in the United States, to the maximum extent practicable. This requirement does not apply to used or leased equipment. The Prime Recipients are required to notify the ARPA-E Contracting Officer reasonably in advance of purchasing any equipment that is not made or manufactured in the United States with a total acquisition cost of \$250,000 or more. Purchases of foreign equipment with a total acquisition cost of \$1,000,000 or more require the approval of the Head of Contracting Activity (HCA). The ARPA-E Contracting Officer will provide consent to purchase or reject within 30 calendar days of receipt of the Recipient's notification.

8. TECHNOLOGY TRANSFER AND OUTREACH

ARPA-E is required to contribute a percentage of appropriated funds to Technology Transfer and Outreach (TT&O) activities. In order to meet this mandate, every Project Team must spend at least 5% of the Federal funding (i.e., the portion of the award that does not include the recipient's cost share) provided by ARPA-E on TT&O activities to promote and further the development and deployment of ARPA-E-funded technologies. Project Teams must also seek a waiver from ARPA-E to spend less than the minimum 5% TT&O expenditure requirement.

All TT&O expenditures are subject to the applicable Federal cost principles (i.e., 2 C.F.R. 200 Subpart E and 48 C.F.R. Subpart 31). Examples of TT&O expenditures are as follows:

- Documented travel and registration for the ARPA-E Energy Innovation Summit and other energy-related conferences and events;
- Documented travel to meet with potential suppliers, partners, or customers;
- Documented work by salaried or contract personnel to develop technology-to-market models or plans;

Questions about this FOA? Check the Frequently Asked Questions available at <http://arpa-e.energy.gov/faq>. For questions that have not already been answered, email ARPA-E-CO@hq.doe.gov (with FOA name and number in subject line); see FOA Sec. VII.A. Problems with ARPA-E eXCHANGE? Email ExchangeHelp@hq.doe.gov (with FOA name and number in subject line).

- Documented costs of acquiring industry-accepted market research reports; and
- Approved patent costs.

ARPA-E will not reimburse recipients for TT&O costs considered to be unallowable in accordance with the applicable cost principles. Examples of unallowable TT&O expenditures include:

- Meals or entertainment;
- Gifts to potential suppliers, partners, or customers;
- TT&O activities that do not relate to the ARPA-E-funded technologies;
- Undocumented TT&O activities; and
- TT&O activities unrelated and/or unallocable to the subject award.

Applicants may seek a waiver of the TT&O requirement by including an explicit request in the Business Assurances & Disclosures Form. Please refer to the Business Assurances & Disclosures Form for guidance on the content and form of the waiver request. ARPA-E may waive or modify the TT&O requirement, as appropriate.

For information regarding incorporation of TT&O costs into budget documentation, see Section IV.D.3 of the FOA.

9. LOBBYING

Prime Recipients and Subrecipients may not use any Federal funds, directly or indirectly, to influence or attempt to influence, directly or indirectly, congressional action on any legislative or appropriation matters pending before Congress, other than to communicate to Members of Congress as described in 18 U.S.C. § 1913. This restriction is in addition to those prescribed elsewhere in statute and regulation.

Prime Recipients and Subrecipients are required to complete and submit SF-LLL, "Disclosure of Lobbying Activities" (<https://www.gsa.gov/forms-library/disclosure-lobbying-activities>) if any non-Federal funds have been paid or will be paid to any person for influencing or attempting to influence any of the following in connection with your application:

- An officer or employee of any Federal agency,
- A Member of Congress,
- An officer or employee of Congress, or
- An employee of a Member of Congress.

10. CONFERENCE SPENDING

Prime Recipients and Subrecipients may not use any Federal funds to:

- Defray the cost to the United States Government of a conference held by any Executive branch department, agency, board, commission, or office which is not directly and programmatically related to the purpose for which their ARPA-E award is made and for which the cost to the United States Government is more than \$20,000; or
- To circumvent the required notification by the head of any such Executive Branch department, agency, board, commission, or office to the Inspector General (or senior ethics official for any entity without an Inspector General), of the date, location, and number of employees attending such a conference.

11. INDEPENDENT RESEARCH AND DEVELOPMENT COSTS

ARPA-E does not fund Independent Research and Development (IR&D) as part of an indirect cost rate under its Grants and Cooperative Agreements. IR&D, as defined at FAR 31.205-18(a), includes cost of effort that is not sponsored by an assistance agreement or required in performance of a contract, and that consists of projects falling within the four following areas: (i) basic research, (ii) applied research, (iii) development, and (iv) systems and other concept formulation studies.

ARPA-E's goals are to enhance the economic and energy security of the United States through the development of energy technologies and ensure that the United States maintains a technological lead in developing and deploying advanced energy technologies. ARPA-E accomplishes these goals by providing financial assistance for energy technology projects, and has well recognized and established procedures for supporting research through competitive financial assistance awards based on merit review of proposed projects. Reimbursement for independent research and development costs through the indirect cost mechanism could circumvent this competitive process.

To ensure that all projects receive similar and equal consideration, eligible organizations may compete for direct funding of independent research projects they consider worthy of support by submitting proposals for those projects to ARPA-E. Since proposals for these projects may be submitted for direct funding, costs for independent research and development projects are not allowable as indirect costs under ARPA-E awards. IR&D costs, however, would still be included in the direct cost base that is used to calculate the indirect rate so as to ensure an appropriate allocation of indirect costs to the organization's direct cost centers.

12. PROHIBITION ON CERTAIN TELECOMMUNICATIONS AND VIDEO SURVEILLANCE SERVICES OR EQUIPMENT

Per 2 C.F.R. § 200.216, recipients and subrecipients are prohibited from obligating or expending grant funds to: (1) procure or obtain; (2) extend or renew a contract to procure or obtain; or (3) enter into a contract (or extend or renew a contract) to procure or obtain equipment, services, or systems that uses covered telecommunications equipment or services as a substantial or essential component of any system, or as critical technology as part of any system. As

described in Public Law 115–232, section 889, covered telecommunications equipment is telecommunications equipment produced by Huawei Technologies Company or ZTE Corporation (or any subsidiary or affiliate of such entities). Refer to 2 C.F.R. § 200.216 for possible additional prohibitions and limitations.

13. BUY AMERICA REQUIREMENT FOR PUBLIC INFRASTRUCTURE PROJECTS

Projects funded through this FOA that are for, or contain, construction, alteration, maintenance, or repair of public infrastructure in the United States undertaken by applicable recipient types, require that:

- All iron, steel, and manufactured products used in the infrastructure project are produced in the United States; and
- All construction materials used in the infrastructure project are manufactured in the United States.

However, ARPA-E does not anticipate soliciting for or selecting projects that propose project tasks that are for, or contain, construction, alteration, maintenance, or repair of public infrastructure. If a project selected for award negotiations includes project tasks that may be subject to the Buy America Requirement, those project tasks will be removed from the project before any award is issued – i.e., no federal funding or Recipient cost share will be available for covered project tasks.

This “Buy America” requirement does not apply to an award where the Prime Recipient is a for-profit entity.

14. REQUIREMENT FOR FINANCIAL PERSONNEL

ARPA-E requires Small Business or Nonprofit applicants to identify a finance/budget professional (employee or contracted support) with an understanding of Federal contracting and/or financial assistance and cost accounting (including indirect costs, invoicing, and financial management systems) that will support the team in complying with all applicable requirements.

H. OTHER SUBMISSION REQUIREMENTS

1. USE OF ARPA-E eXCHANGE

To apply to this FOA, Applicants must register with ARPA-E eXCHANGE (<https://arpa-e-foa.energy.gov/Registration.aspx>). Concept Papers, Full Applications, and Replies to Reviewer Comments must be submitted through ARPA-E eXCHANGE (<https://arpa-e-foa.energy.gov/login.aspx>). ARPA-E will not review or consider applications submitted through other means (e.g., fax, hand delivery, email, postal mail). For detailed guidance on using ARPA-

Questions about this FOA? Check the Frequently Asked Questions available at <http://arpa-e.energy.gov/faq>. For questions that have not already been answered, email ARPA-E-CO@hq.doe.gov (with FOA name and number in subject line); see FOA Sec. VII.A. Problems with ARPA-E eXCHANGE? Email ExchangeHelp@hq.doe.gov (with FOA name and number in subject line).

E eXCHANGE, please refer to the “ARPA-E eXCHANGE Applicant Guide” (<https://arpa-e-foa.energy.gov/Manuals.aspx>).

Upon creating an application submission in ARPA-E eXCHANGE, Applicants will be assigned a Control Number. If the Applicant creates more than one application submission, a different Control Number will be assigned for each application.

Once logged in to ARPA-E eXCHANGE (<https://arpa-e-foa.energy.gov/login.aspx>), Applicants may access their submissions by clicking the “My Submissions” link in the navigation on the left side of the page. Every application that the Applicant has submitted to ARPA-E and the corresponding Control Number is displayed on that page. If the Applicant submits more than one application to a particular FOA, a different Control Number is shown for each application.

Applicants are responsible for meeting each submission deadline in ARPA-E eXCHANGE. **Applicants are strongly encouraged to submit their applications at least 48 hours in advance of the submission deadline.** Under normal conditions (i.e., at least 48 hours in advance of the submission deadline), Applicants should allow at least 1 hour to submit a Concept Paper, or Full Application. In addition, Applicants should allow at least 15 minutes to submit a Reply to Reviewer Comments. Once the application is submitted in ARPA-E eXCHANGE, Applicants may revise or update their application until the expiration of the applicable deadline.

Applicants should not wait until the last minute to begin the submission process. During the final hours before the submission deadline, Applicants may experience server/connection congestion that prevents them from completing the necessary steps in ARPA-E eXCHANGE to submit their applications. **ARPA-E will not extend the submission deadline for Applicants that fail to submit required information and documents due to server/connection congestion.**

ARPA-E may not review or consider incomplete applications and applications received after the deadline stated in the FOA. Such applications may be deemed noncompliant (see Section III.C.1 of the FOA). The following errors could cause an application to be deemed “incomplete” and thus noncompliant:

- Failing to comply with the form and content requirements in Section IV of the FOA;
- Failing to enter required information in ARPA-E eXCHANGE;
- Failing to upload required document(s) to ARPA-E eXCHANGE;
- Failing to click the “Submit” button in ARPA-E eXCHANGE by the deadline stated in the FOA;
- Uploading the wrong document(s) or application(s) to ARPA-E eXCHANGE; and
- Uploading the same document twice, but labeling it as different documents. (In the latter scenario, the Applicant failed to submit a required document.)

ARPA-E urges Applicants to carefully review their applications and to allow sufficient time for the submission of required information and documents.

Questions about this FOA? Check the Frequently Asked Questions available at <http://arpa-e.energy.gov/faq>. For questions that have not already been answered, email ARPA-E-CO@hq.doe.gov (with FOA name and number in subject line); see FOA Sec. VII.A. Problems with ARPA-E eXCHANGE? Email ExchangeHelp@hq.doe.gov (with FOA name and number in subject line).

IV. APPLICATION REVIEW INFORMATION

A. CRITERIA

ARPA-E performs a preliminary review of Concept Papers and Full Applications to determine whether they are compliant and responsive (see Section III.C of the FOA). ARPA-E also performs a preliminary review of Replies to Reviewer Comments to determine whether they are compliant.

ARPA-E considers a mix of quantitative and qualitative criteria in determining whether to encourage the submission of a Full Application and whether to select a Full Application for award negotiations.

12. CRITERIA FOR CONCEPT PAPERS

(1) *Impact of the Proposed Technology Relative to FOA Targets (50%)* - This criterion involves consideration of the following:

- The potential for a transformational and disruptive (not incremental) advancement compared to existing or emerging technologies;
- Achievement of the technical performance targets defined in Section I.E of the FOA for the appropriate technology Category in Section I.D of the FOA;
- Identification of techno-economic challenges that must be overcome for the proposed technology to be commercially relevant; and
- Demonstration of awareness of competing commercial and emerging technologies and identifies how the proposed concept/technology provides significant improvement over existing solutions.

(2) *Overall Scientific and Technical Merit (50%)* - This criterion involves consideration of the following:

- The feasibility of the proposed work, as justified by appropriate background, theory, simulation, modeling, experimental data, or other sound scientific and engineering practices;
- Sufficiency of technical approach to accomplish the proposed R&D objectives, including why the proposed concept is more appropriate than alternative approaches and how technical risk will be mitigated;
- Clearly defined project outcomes and final deliverables; and
- The demonstrated capabilities of the individuals performing the project, the key capabilities of the organizations comprising the Project Team, the roles and responsibilities of each organization and (if applicable) previous collaborations among team members supporting the proposed project.

Questions about this FOA? Check the Frequently Asked Questions available at <http://arpa-e.energy.gov/faq>. For questions that have not already been answered, email ARPA-E-CO@hq.doe.gov (with FOA name and number in subject line); see FOA Sec. VII.A. Problems with ARPA-E eXCHANGE? Email ExchangeHelp@hq.doe.gov (with FOA name and number in subject line).

Submissions will not be evaluated against each other since they are not submitted in accordance with a common work statement.

13. CRITERIA FOR FULL APPLICATIONS

Full Applications are evaluated based on the following criteria:

(1) *Impact of the Proposed Technology* (30%) - This criterion involves consideration of the following:

- The potential for a transformational and disruptive (not incremental) advancement in one or more energy-related fields;
- Thorough understanding of the current state-of-the-art and presentation of an innovative technical approach to significantly improve performance over the current state-of-the-art;
- Awareness of competing commercial and emerging technologies and identification of how the proposed concept/technology provides significant improvement over these other solutions; and
- A reasonable and effective strategy for transitioning the proposed technology from the laboratory to commercial deployment.

(2) *Overall Scientific and Technical Merit* (30%) - This criterion involves consideration of the following:

- Whether the proposed work is unique and innovative;
- Clearly defined project outcomes and final deliverables;
- Substantiation that the proposed project is likely to meet or exceed the technical performance targets identified in this FOA;
- Feasibility of the proposed work based upon preliminary data or other background information and sound scientific and engineering practices and principles;
- A sound technical approach, including appropriately defined technical tasks, to accomplish the proposed R&D objectives; and
- Management of risk, to include identifying major technical R&D risks and feasible, effective mitigation strategies.

(3) *Qualifications, Experience, and Capabilities of the Proposed Project Team* (30%) - This criterion involves consideration of the following:

- The PI and Project Team have the skill and expertise needed to successfully execute the project plan, evidenced by prior experience that demonstrates an ability to perform R&D of similar risk and complexity; and

Questions about this FOA? Check the Frequently Asked Questions available at <http://arpa-e.energy.gov/faq>. For questions that have not already been answered, email ARPA-E-CO@hq.doe.gov (with FOA name and number in subject line); see FOA Sec. VII.A. Problems with ARPA-E eXCHANGE? Email ExchangeHelp@hq.doe.gov (with FOA name and number in subject line).

- Access to the equipment and facilities necessary to accomplish the proposed R&D effort and/or a clear plan to obtain access to necessary equipment and facilities.

(4) *Soundness of Management Plan* (10%) - This criterion involves consideration of the following:

- Plausibility of plan to manage people and resources;
- Allocation of appropriate levels of effort and resources to proposed tasks;
- Reasonableness of the proposed project schedule, including major milestones; and
- Reasonableness of the proposed budget to accomplish the proposed project.

Submissions will not be evaluated against each other since they are not submitted in accordance with a common work statement.

The above criteria will be weighted as follows:

Impact of the Proposed Technology	30%
Overall Scientific and Technical Merit	30%
Qualifications, Experience, and Capabilities of the Proposed Project Team	30%
Soundness of Management Plan	10%

14. CRITERIA FOR REPLIES TO REVIEWER COMMENTS

ARPA-E has not established separate criteria to evaluate Replies to Reviewer Comments. Instead, Replies to Reviewer Comments are evaluated as an extension of the Full Application.

B. REVIEW AND SELECTION PROCESS

1. PROGRAM POLICY FACTORS

In addition to the above criteria, ARPA-E may consider the following program policy factors in determining which Concept Papers to encourage to submit a Full Application and which Full Applications to select for award negotiations:

- I. **ARPA-E Portfolio Balance.** Project balances ARPA-E portfolio in one or more of the following areas:
 - a. Diversity of technical personnel in the proposed Project Team;
 - b. Technological diversity;
 - c. Organizational diversity;
 - d. Geographic diversity;
 - e. Technical or commercialization risk; or
 - f. Stage of technology development.

Questions about this FOA? Check the Frequently Asked Questions available at <http://arpa-e.energy.gov/faq>. For questions that have not already been answered, email ARPA-E-CO@hq.doe.gov (with FOA name and number in subject line); see FOA Sec. VII.A. Problems with ARPA-E eXCHANGE? Email ExchangeHelp@hq.doe.gov (with FOA name and number in subject line).

- II. **Relevance to ARPA-E Mission Advancement.** Project contributes to one or more of ARPA-E's key statutory goals:
 - a. Reduction of U.S. dependence on foreign energy sources;
 - b. Stimulation of U.S. manufacturing and/or software development
 - c. Reduction of energy-related emissions;
 - d. Increase in U.S. energy efficiency;
 - e. Enhancement of U.S. economic and energy security; or
 - f. Promotion of U.S. advanced energy technologies competitiveness.

- III. **Synergy of Public and Private Efforts.**
 - a. Avoids duplication and overlap with other publicly or privately funded projects;
 - b. Promotes increased coordination with nongovernmental entities for demonstration of technologies and research applications to facilitate technology transfer; or
 - c. Increases unique research collaborations.

- IV. **Low likelihood of other sources of funding.** High technical and/or financial uncertainty that results in the non-availability of other public, private or internal funding or resources to support the project.

- V. **High-Leveraging of Federal Funds.** Project leverages Federal funds to optimize advancement of programmatic goals by proposing cost share above the required minimum or otherwise accessing scarce or unique resources.

- VI. **High Project Impact Relative to Project Cost.**

- VII. **Qualified Opportunity Zone (QOZ).** Whether the entity is located in an urban and economically distressed area including a Qualified Opportunity Zone (QOZ) or the proposed project will occur in a QOZ or otherwise advance the goals of QOZ. The goals include spurring economic development and job creation in distressed communities throughout the United States. For a list or map of QOZs go to:
<https://www.cdfifund.gov/opportunity-zones>.

2. ARPA-E REVIEWERS

By submitting an application to ARPA-E, Applicants consent to ARPA-E's use of Federal employees, contractors, and experts from educational institutions, nonprofits, industry, and governmental and intergovernmental entities as reviewers. ARPA-E selects reviewers based on their knowledge and understanding of the relevant field and application, their experience and skills, and their ability to provide constructive feedback on applications.

ARPA-E requires all reviewers to complete a Conflict-of-Interest Certification and Nondisclosure Agreement through which they disclose their knowledge of any actual or apparent conflicts and

Questions about this FOA? Check the Frequently Asked Questions available at <http://arpa-e.energy.gov/faq>. For questions that have not already been answered, email ARPA-E-CO@hq.doe.gov (with FOA name and number in subject line); see FOA Sec. VII.A. Problems with ARPA-E eXCHANGE? Email ExchangeHelp@hq.doe.gov (with FOA name and number in subject line).

agree to safeguard confidential information contained in Concept Papers, Full Applications, and Replies to Reviewer Comments. In addition, ARPA-E trains its reviewers in proper evaluation techniques and procedures.

Applicants are not permitted to nominate reviewers for their applications. Applicants may contact the Contracting Officer by email (ARPA-E-CO@hq.doe.gov) if they have knowledge of a potential conflict of interest or a reasonable belief that a potential conflict exists.

3. ARPA-E SUPPORT CONTRACTOR

ARPA-E utilizes contractors to assist with the evaluation of applications and project management. To avoid actual and apparent conflicts of interest, ARPA-E prohibits its support contractors from submitting or participating in the preparation of applications to ARPA-E.

By submitting an application to ARPA-E, Applicants represent that they are not performing support contractor services for ARPA-E in any capacity and did not obtain the assistance of ARPA-E's support contractor to prepare the application. ARPA-E will not consider any applications that are submitted by or prepared with the assistance of its support contractors.

C. ANTICIPATED ANNOUNCEMENT AND AWARD DATES

ARPA-E expects to announce selections for negotiations in approximately August 2023 and to execute funding agreements in approximately December 2023.

V. AWARD ADMINISTRATION INFORMATION

A. AWARD NOTICES

1. REJECTED SUBMISSIONS

Noncompliant and nonresponsive Concept Papers and Full Applications are rejected by the Contracting Officer and are not merit reviewed or considered for award. The Contracting Officer sends a notification letter by email to the technical and administrative points of contact designated by the Applicant in ARPA-E eXCHANGE. The notification letter states the basis upon which the Concept Paper or Full Application was rejected.

2. CONCEPT PAPER NOTIFICATIONS

ARPA-E promptly notifies Applicants of its determination to encourage or discourage the submission of a Full Application. ARPA-E sends a notification letter by email to the technical and administrative points of contact designated by the Applicant in ARPA-E eXCHANGE. ARPA-E provides feedback in the notification letter in order to guide further development of the proposed technology.

Applicants may submit a Full Application even if they receive a notification discouraging them from doing so. By discouraging the submission of a Full Application, ARPA-E intends to convey its lack of programmatic interest in the proposed project. Such assessments do not necessarily reflect judgments on the merits of the proposed project. The purpose of the Concept Paper phase is to save Applicants the considerable time and expense of preparing a Full Application that is unlikely to be selected for award negotiations.

A notification letter encouraging the submission of a Full Application does not authorize the Applicant to commence performance of the project. Please refer to Section IV.G of the FOA for guidance on pre-award costs.

3. FULL APPLICATION NOTIFICATIONS

ARPA-E promptly notifies Applicants of its determination. ARPA-E sends a notification letter by email to the technical and administrative points of contact designated by the Applicant in ARPA-E eXCHANGE. The notification letter may inform the Applicant that its Full Application was selected for award negotiations, or not selected. Alternatively, ARPA-E may notify one or more Applicants that a final selection determination on particular Full Applications will be made at a later date, subject to the availability of funds and other factors.

Written feedback on Full Applications is made available to Applicants before the submission deadline for Replies to Reviewer Comments. By providing feedback, ARPA-E intends to guide

the further development of the proposed technology and to provide a brief opportunity to respond to reviewer comments.

a. SUCCESSFUL APPLICANTS

ARPA-E has discretion to select all or part of a proposed project for negotiation of an award. A notification letter selecting a Full Application for award negotiations does not authorize the Applicant to commence performance of the project. **ARPA-E selects Full Applications for award negotiations, not for award.** Applicants do not receive an award until award negotiations are complete and the Contracting Officer executes the funding agreement. ARPA-E may terminate award negotiations at any time for any reason.

Please refer to Section IV.G.2 of the FOA for guidance on pre-award costs.

b. POSTPONED SELECTION DETERMINATIONS

A notification letter postponing a final selection determination until a later date does not authorize the Applicant to commence performance of the project. ARPA-E may ultimately determine to select or not select the Full Application for award negotiations.

Please refer to Section IV.G.2 of the FOA for guidance on pre-award costs.

c. UNSUCCESSFUL APPLICANTS

By not selecting a Full Application, ARPA-E intends to convey its lack of programmatic interest in the proposed project. Such assessments do not necessarily reflect judgments on the merits of the proposed project. ARPA-E hopes that unsuccessful Applicants will submit innovative ideas and concepts for future FOAs.

B. ADMINISTRATIVE AND NATIONAL POLICY REQUIREMENTS

The following administrative and national policy requirements apply to Prime Recipients. The Prime Recipient is the responsible authority regarding the settlement and satisfaction of all contractual and administrative issues, including but not limited to disputes and claims arising out of any agreement between the Prime Recipient and a FFRDC contractor. Prime Recipients are required to flow down these requirements to their Subrecipients through subawards or related agreements.

- If an award is made to a DOE/NNSA National Laboratory, all Disputes and Claims will be resolved in accordance with the terms and conditions of the DOE/NNSA National Laboratory's management and operating (M&O) contract, as applicable, in consultation between DOE and the prime awardee.
- If an award is made to another Federal agency or its FFRDC contractor, all Disputes and Claims will be resolved in accordance with the terms and

Questions about this FOA? Check the Frequently Asked Questions available at <http://arpa-e.energy.gov/faq>. For questions that have not already been answered, email ARPA-E-CO@hq.doe.gov (with FOA name and number in subject line); see FOA Sec. VII.A. Problems with ARPA-E eXCHANGE? Email ExchangeHelp@hq.doe.gov (with FOA name and number in subject line).

conditions of the interagency agreement in consultation between DOE and the prime awardee.

1. UNIQUE ENTITY IDENTIFIER AND SAM, FSRS, AND FEDCONNECT REGISTRATIONS

Prime Recipients must register with the System for Award Management (SAM) at www.sam.gov/SAM prior to submitting an application, at which time the system will assign (if newly registered) a Unique Entity Identifier (UEI).

Prime Recipients must:

- Maintain an active SAM registration with current information, including information on a its immediate and highest-level owner and subsidiaries, as well as on all predecessors that have been awarded a Federal contract or financial assistance award within the last three years, if applicable, at all times during which it has an active Federal award or an application or plan under consideration by a Federal awarding agency;
- Remain registered in the SAM database after the initial registration;
- Update its information in the SAM database as soon as it changes;
- Review its information in the SAM database on an annual basis from the date of initial registration or subsequent updates to ensure it is current, accurate and complete; and
- Not make a subaward to any entity unless the entity has provided its UEI.

Subrecipients are not required to register in SAM, but must obtain a UEI.

Prime Recipients and Subrecipients should commence this process as soon as possible in order to expedite the execution of a funding agreement. Registering with SAM and obtaining the UEI could take several weeks.

Prime Recipients are also required to register with the Federal Funding Accountability and Transparency Act Subaward Reporting System (FSRS) at <https://www.fsrs.gov/>.⁷⁰ Prime Recipients are required to report to FSRS the names and total compensation of each of the Prime Recipient's five most highly compensated executives and the names and total compensation of each Subrecipient's five most highly compensated executives. Please refer to <https://www.fsrs.gov/> for guidance on reporting requirements. Prime Recipients are required to keep the FSRS data current throughout the duration of the project.

ARPA-E may not execute a funding agreement with the Prime Recipient until it has obtained a UEI and completed its SAM and FSRS registrations.

Finally, Prime Recipients are required to register with FedConnect in order to receive notification that their funding agreement has been executed by the Contracting Officer and to obtain a copy of the executed funding agreement. Please refer to

⁷⁰ The Federal Funding Accountability and Transparency Act, P.L. 109-282, 31 U.S.C. 6101 note.

<https://www.fedconnect.net/FedConnect/> for registration instructions.

2. NATIONAL POLICY ASSURANCES

Project Teams, including Prime Recipients and Subrecipients, are required to comply with the National Policy Assurances attached to their funding agreement in accordance with 2 C.F.R. § 200.300. Refer to Attachment 6 of ARPA-E's Model Cooperative Agreement (<https://arpa-e.energy.gov/technologies/project-guidance/pre-award-guidance/funding-agreements>) for information on the National Policy Assurances.

3. PROOF OF COST SHARE COMMITMENT AND ALLOWABILITY

Upon selection for award negotiations, the Prime Recipient must confirm in writing that the proposed cost share contribution is allowable in accordance with applicable Federal cost principles.

The Prime Recipient is also required to provide cost share commitment letters from Subrecipients or third parties that are providing cost share, whether cash or in-kind. Each Subrecipient or third party that is contributing cost share must provide a letter on appropriate letterhead that is signed by an authorized corporate representative.

4. COST SHARE PAYMENTS⁷¹

All proposed cost share contributions must be reviewed in advance by the Contracting Officer and incorporated into the project budget before the expenditures are incurred.

The Prime Recipient is required to pay the "Cost Share" amount as a percentage of the total project costs in each invoice period for the duration of the period of performance. Small Businesses should refer to Section III.B.3 of the FOA.

ARPA-E may deny reimbursement requests, in whole or in part, or modify or terminate funding agreements where Prime Recipients (or Project Teams) fail to comply with ARPA-E's cost share payment requirements.

5. ENVIRONMENTAL IMPACT QUESTIONNAIRE

By law, ARPA-E is required to evaluate the potential environmental impact of projects that it is considering for funding. In particular, ARPA-E must determine before funding a project whether the project qualifies for a categorical exclusion under 10 C.F.R. § 1021.410 or whether it requires further environmental review (i.e., an environmental assessment or an environmental impact statement).

⁷¹ Please refer to Section III.B of the FOA for guidance on cost share requirements.

To facilitate and expedite ARPA-E's environmental review, Prime Recipients are required to complete an Environmental Impact Questionnaire during award negotiations. This form is available at <https://arpa-e.energy.gov/technologies/project-guidance/pre-award-guidance/required-forms-and-templates>. Each Prime Recipient must wait to complete the Environmental Impact Questionnaire (EIQ) until after ARPA-E has notified them that Attachment 3 Statement of Program Objectives is in final form. The completed EIQ is then due back to ARPA-E within 14 calendar days.

6. TECHNOLOGY-TO-MARKET PLAN

During award negotiations, Prime Recipients are required to negotiate and submit an initial Technology-to-Market Plan to the ARPA-E Program Director and obtain the ARPA-E Program Director's approval prior to the execution of the award. Prime Recipients must show how any budgeted Technology Transfer and Outreach (TT&O) costs relate to furthering elements of the Technology-to-Market Plan. During the period of performance, Prime Recipients are required to provide regular updates on the initial Technology-to-Market plan and report on implementation of Technology-to-Market activities. Prime Recipients may be required to perform other actions to further the commercialization of their respective technologies.

ARPA-E may waive or modify this requirement, as appropriate.

7. INTELLECTUAL PROPERTY AND DATA MANAGEMENT PLANS

ARPA-E requires every Project Team to negotiate and establish an Intellectual Property Management Plan for the management and disposition of intellectual property arising from the project. The Prime Recipient must submit a completed and signed Intellectual Property Management plan to ARPA-E within six weeks of the effective date of the ARPA-E funding agreement. All Intellectual Property Management Plans are subject to the terms and conditions of the ARPA-E funding agreement and its intellectual property provisions, and applicable Federal laws, regulations, and policies, all of which take precedence over the terms of Intellectual Property Management Plans.

ARPA-E has developed a template for Intellectual Property Management Plans (<https://arpa-e.energy.gov/technologies/project-guidance/post-award-guidance/project-management-reporting-requirements>) so as to facilitate and expedite negotiations between Project Team members. ARPA-E does not mandate the use of this template. ARPA-E and DOE do not make any warranty (express or implied) or assume any liability or responsibility for the accuracy, completeness, or usefulness of the template. ARPA-E and DOE strongly encourage Project Teams to consult independent legal counsel before using the template.

Awardees are also required, post-award, to submit a Data Management Plan (DMP) that addresses how data generated in the course of the work performed under an ARPA-E award

will be preserved and, as appropriate, shared publicly. The Prime Recipient must submit a completed and signed DMP - as part of the Team's Intellectual Property Management Plan - to ARPA-E within six weeks of the effective date of the ARPA-E funding agreement.

8. U.S. COMPETITIVENESS

A primary objective of DOE's multi-billion dollar research, development and demonstration investments – including ARPA-E awards - is advancement of new energy technologies, manufacturing capabilities, and supply chains for and by U.S. industry and labor. Therefore, in exchange for receiving taxpayer dollars to support an applicant's project, the applicant must agree to the following U.S. Competitiveness Provision as part of an award under this FOA.

U.S. Competitiveness

The Contractor (Prime Recipient in ARPA-E awards) agrees that any products embodying any subject invention or produced through the use of any subject invention will be manufactured substantially in the United States unless the Contractor can show to the satisfaction of DOE that it is not commercially feasible. In the event DOE agrees to foreign manufacture, there will be a requirement that the Government's support of the technology be recognized in some appropriate manner, e.g., alternative binding commitments to provide an overall net benefit to the U.S. economy. The Contractor agrees that it will not license, assign or otherwise transfer any subject invention to any entity, at any tier, unless that entity agrees to these same requirements. Should the Contractor or other such entity receiving rights in the invention(s): (1) undergo a change in ownership amounting to a controlling interest, or (2) sell, assign, or otherwise transfer title or exclusive rights in the invention(s), then the assignment, license, or other transfer of rights in the subject invention(s) is/are suspended until approved in writing by DOE. The Contractor and any successor assignee will convey to DOE, upon written request from DOE, title to any subject invention, upon a breach of this paragraph. The Contractor will include this paragraph in all subawards/contracts, regardless of tier, for experimental, developmental or research work.

A subject invention is any invention of the contractor conceived or first actually reduced to practice in the performance of work under an award. An invention is any invention or discovery which is or may be patentable. The contractor includes any awardee, recipient, sub-awardee, or sub-recipient.

As noted in the U.S. Competitiveness Provision, at any time in which an entity cannot meet the requirements of the U.S. Competitiveness Provision, the entity may request a modification or waiver of the U.S. Competitiveness Provision. For example, the entity may propose modifying the language of the U.S. Competitiveness Provision in order to change the scope of the requirements or to provide more specifics on the application of the requirements for a particular technology. As another example, the entity may request that the U.S. Competitiveness Provision be waived in lieu of a net benefits statement or U.S. manufacturing plan. The statement or plan would contain specific

and enforceable commitments that would be beneficial to the U.S. economy and competitiveness. Commitments could include manufacturing specific products in the U.S., making a specific investment in a new or existing U.S. manufacturing facility, keeping certain activities based in the U.S. or supporting a certain number of jobs in the U.S. related to the technology. If DOE, in its sole discretion, determines that the proposed modification or waiver promotes commercialization and provides substantial U.S. economic benefits, DOE may grant the request and, if granted, modify the award terms and conditions for the requesting entity accordingly.

The U.S. Competitiveness Provision is implemented by DOE pursuant to a Determination of Exceptional Circumstances (DEC) under the Bayh-Dole Act and DOE Patent Waivers. See Section VIII.A, "Title to Subject Inventions", of this FOA for more information on the DEC and DOE Patent Waiver.

9. CORPORATE FELONY CONVICTIONS AND FEDERAL TAX LIABILITY

In submitting an application in response to this FOA, the Applicant represents that:

- It is not a corporation that has been convicted of a felony criminal violation under any Federal law within the preceding 24 months; and
- It is not a corporation that has any unpaid Federal tax liability that has been assessed, for which all judicial and administrative remedies have been exhausted or have lapsed, and that is not being paid in a timely manner pursuant to an agreement with the authority responsible for collecting the tax liability.

For purposes of these representations the following definitions apply: A Corporation includes any entity that has filed articles of incorporation in any of the 50 states, the District of Columbia, or the various territories of the United States [but not foreign corporations]. It includes both for-profit and non-profit organizations.

10. APPLICANT RISK ANALYSIS

If selected for award negotiations, ARPA-E may evaluate the risks posed by the Applicant using the criteria set forth at 2 CFR §200.206(b)(ii). ARPA-E may require special award terms and conditions depending upon results of the risk analysis.

ARPA-E will not make an award if ARPA-E has determined that:

- The entity submitting the proposal or application:
 - has an owner or covered individual that is party to a malign foreign talent recruitment program;
 - has a business entity, parent company, or subsidiary located in the People's Republic of China or another foreign country of concern; or

- has an owner or covered individual that has a foreign affiliation with a research institution located in the People's Republic of China or another foreign country of concern; and
- The relationships and commitments described above:
 - interfere with the capacity for activities supported by the Federal agency to be carried out;
 - create duplication with activities supported by the Federal agency;
 - present concerns about conflicts of interest;
 - were not appropriately disclosed to the Federal agency;
 - violate Federal law or terms and conditions of the Federal agency; or
 - pose a risk to national security.

11. RECIPIENT INTEGRITY AND PERFORMANCE MATTERS

Prior to making a Federal award, ARPA-E is required to review and consider any information about Applicants that is contained in the Office of Management and Budget's designated integrity and performance system accessible through SAM (currently the Federal Awardee Performance and Integrity Information System or FAPIIS) (41 U.S.C. § 2313 and 2 C.F.R. 200.206).

Applicants may review information in FAPIIS and comment on any information about itself that a Federal awarding agency previously entered into FAPIIS.

ARPA-E will consider any written comments provided by Applicants during award negotiations, in addition to the other information in FAPIIS, in making a judgment about an Applicant's integrity, business ethics, and record of performance under Federal awards when reviewing potential risk posed by Applicants as described in 2 C.F.R. §200.206.

12. NONDISCLOSURE AND CONFIDENTIALITY AGREEMENTS REPRESENTATIONS

In submitting an application in response to this FOA the Applicant represents that:

- (1) **It does not and will not** require its employees or contractors to sign internal nondisclosure or confidentiality agreements or statements prohibiting or otherwise restricting its employees or contractors from lawfully reporting waste, fraud, or abuse to a designated investigative or law enforcement representative of a Federal department or agency authorized to receive such information.
- (2) **It does not and will not** use any Federal funds to implement or enforce any nondisclosure and/or confidentiality policy, form, or agreement it uses unless it contains the following provisions:

- a. *“These provisions are consistent with and do not supersede, conflict with, or otherwise alter the employee obligations, rights, or liabilities created by existing statute or Executive order relating to (1) classified information, (2) communications to Congress, (3) the reporting to an Inspector General of a violation of any law, rule, or regulation, or mismanagement, a gross waste of funds, an abuse of authority, or a substantial and specific danger to public health or safety, or (4) any other whistleblower protection. The definitions, requirements, obligations, rights, sanctions, and liabilities created by controlling Executive orders and statutory provisions are incorporated into this agreement and are controlling.”*
- b. The limitation above shall not contravene requirements applicable to Standard Form 312, Form 4414, or any other form issued by a Federal department or agency governing the nondisclosure of classified information.
- c. Notwithstanding the provision listed in paragraph (a), a nondisclosure confidentiality policy form or agreement that is to be executed by a person connected with the conduct of an intelligence or intelligence-related activity, other than an employee or officer of the United States Government, may contain provisions appropriate to the particular activity for which such document is to be used. Such form or agreement shall, at a minimum, require that the person will not disclose any classified information received in the course of such activity unless specifically authorized to do so by the United States Government. Such nondisclosure or confidentiality forms shall also make it clear that they do not bar disclosure to congress, or to an authorized official of an executive agency or the Department of Justice, that are essential to reporting a substantial violation of law.

13. INTERIM CONFLICT OF INTEREST POLICY FOR FINANCIAL ASSISTANCE

The DOE interim Conflict of Interest Policy for Financial Assistance (COI Policy) can be found at <https://www.energy.gov/management/financial-assistance-letter-no-fal-2022-02>. This policy is applicable to all non-Federal entities applying for, or that receive, DOE funding by means of a financial assistance award (e.g., a grant, cooperative agreement, or technology investment agreement) and, through the implementation of this policy by the entity, to each Investigator who is planning to participate in, or is participating in, the project funded wholly or in part under the DOE financial assistance award. DOE’s interim COI Policy establishes standards that provide a reasonable expectation that the design, conduct, and reporting of projects funded wholly or in part under DOE financial assistance awards will be free from bias resulting from financial conflicts of interest or organizational conflicts of interest. The applicant is subject to the requirements of the interim COI Policy and within each application for financial assistance, the applicant must certify that it is, or will be by the time of receiving any financial assistance award, compliant with all requirements in the interim COI Policy. For applicants to any ARPA-E Funding Opportunity Announcement, this certification, disclosure of any managed or unmanaged conflicts of interest, and a copy of (or link to) the applicant’s own conflict of interest policy must be included with the information provided in the Business Assurances &

Disclosures Form. The applicant must also flow down the requirements of the interim COI Policy to any subrecipient non-Federal entities.

14. COMMERCIALIZATION PLAN AND SOFTWARE REPORTING

If your project is selected and it targets the development of software, you may be required to prepare a Commercialization Plan for the targeted software and agree to special provisions that require the reporting of the targeted software and its utilization. This special approach to projects that target software mirrors the requirements for reporting that attach to new inventions made in performance of an award.

C. REPORTING

Recipients are required to submit periodic, detailed reports on technical, financial, and other aspects of the project, as described in Attachment 4 to ARPA-E's Model Cooperative Agreement (<https://arpa-e.energy.gov/technologies/project-guidance/pre-award-guidance/funding-agreements>).

VI. AGENCY CONTACTS

A. COMMUNICATIONS WITH ARPA-E

Upon the issuance of a FOA, only the Contracting Officer may communicate with Applicants. ARPA-E personnel and our support contractors are prohibited from communicating (in writing or otherwise) with Applicants regarding the FOA. This “quiet period” remains in effect until ARPA-E’s public announcement of its project selections.

During the “quiet period,” Applicants are required to submit all questions regarding this FOA to ARPA-E-CO@hq.doe.gov. Questions and Answers (Q&As) about ARPA-E and the FOA are available at <http://arpa-e.energy.gov/faq>. For questions that have not already been answered, please send an email with the FOA name and number in the subject line to ARPA-E-CO@hq.doe.gov. Due to the volume of questions received, ARPA-E will only answer pertinent questions that have not yet been answered and posted at the above link.

- ARPA-E will post responses on a weekly basis to any questions that are received that have not already been addressed at the link above. ARPA-E may re-phrase questions or consolidate similar questions for administrative purposes.
- ARPA-E will cease to accept questions approximately 10 business days in advance of each submission deadline. Responses to questions received before the cutoff will be posted no later than three business days in advance of the submission deadline. ARPA-E may re-phrase questions or consolidate similar questions for administrative purposes.
- Responses are published in a document specific to this FOA under “CURRENT FUNDING OPPORTUNITIES – FAQs” on ARPA-E’s website (<http://arpa-e.energy.gov/faq>).

Applicants may submit questions regarding ARPA-E eXCHANGE, ARPA-E’s online application portal, to ExchangeHelp@hq.doe.gov. ARPA-E will promptly respond to emails that raise legitimate, technical issues with ARPA-E eXCHANGE. ARPA-E will refer any questions regarding the FOA to ARPA-E-CO@hq.doe.gov.

ARPA-E will not accept or respond to communications received by other means (e.g., fax, telephone, mail, hand delivery). Emails sent to other email addresses will be disregarded.

During the “quiet period,” only the Contracting Officer may authorize communications between ARPA-E personnel and Applicants. The Contracting Officer may communicate with Applicants as necessary and appropriate. As described in Section IV.A of the FOA, the Contracting Officer may arrange pre-selection meetings and/or site visits during the “quiet period.”

Questions about this FOA? Check the Frequently Asked Questions available at <http://arpa-e.energy.gov/faq>. For questions that have not already been answered, email ARPA-E-CO@hq.doe.gov (with FOA name and number in subject line); see FOA Sec. VII.A. Problems with ARPA-E eXCHANGE? Email ExchangeHelp@hq.doe.gov (with FOA name and number in subject line).

B. DEBRIEFINGS

ARPA-E does not offer or provide debriefings. ARPA-E provides Applicants with a notification encouraging or discouraging the submission of a Full Application based on ARPA-E's assessment of the Concept Paper. In addition, ARPA-E provides Applicants with reviewer comments on Full Applications before the submission deadline for Replies to Reviewer Comments.

VII. OTHER INFORMATION

A. TITLE TO SUBJECT INVENTIONS

Ownership of subject inventions is governed pursuant to the authorities listed below:

- Domestic Small Businesses, Educational Institutions, and Nonprofits: Under the Bayh-Dole Act (35 U.S.C. § 200 et seq.), domestic small businesses, educational institutions, and nonprofits may elect to retain title to their subject inventions;
- All other parties: The federal Non-Nuclear Energy Act of 1974, 42 U.S.C. 5908, provides that the government obtains title to new subject inventions unless a waiver is granted (see below):
 - Class Patent Waiver for Domestic Large Businesses: DOE has issued a class patent waiver that applies to this FOA. Under this class patent waiver, domestic large businesses may elect title to their subject inventions similar to the right provided to the domestic small businesses, educational institutions, and nonprofits by law. In order to avail itself of the class patent waiver, a domestic large business must agree to the U.S. Competitiveness Provision in accordance with Section VI.B.8. of this FOA.
 - Advance and Identified Waivers: For applicants that do not fall under the class patent waiver or the Bayh-Dole Act, those applicants may request a patent waiver that will cover subject inventions that may be made under the award, in advance of or within 30 days after the effective date of the award. Even if an advance waiver is not requested or the request is denied, the recipient will have a continuing right under the award to request a waiver for identified inventions, i.e., individual subject inventions that are disclosed to DOE within the time frames set forth in the award's intellectual property terms and conditions. Any patent waiver that may be granted is subject to certain terms and conditions in 10 CFR 784.
- DEC: On June 07, 2021, DOE approved a DETERMINATION OF EXCEPTIONAL CIRCUMSTANCES (DEC) UNDER THE BAYH-DOLE ACT TO FURTHER PROMOTE DOMESTIC MANUFACTURE OF DOE SCIENCE AND ENERGY TECHNOLOGIES. In accordance with this DEC, all awards, including sub-awards, under this FOA made to a Bayh-Dole entity (domestic small businesses and nonprofit organizations) shall include the U.S. Competitiveness Provision in accordance with Section VI.B.8 of this FOA. A copy of the DEC may be found on the DoE website. Pursuant to 37 CFR § 401.4, any Bayh-Dole entity affected by this DEC has the right to appeal it by providing written notice to DOE within 30 working days from the time it receives a copy of the determination.

B. GOVERNMENT RIGHTS IN SUBJECT INVENTIONS

Where Prime Recipients and Subrecipients retain title to subject inventions, the U.S. Government retains certain rights.

Questions about this FOA? Check the Frequently Asked Questions available at <http://arpa-e.energy.gov/faq>. For questions that have not already been answered, email ARPA-E-CO@hq.doe.gov (with FOA name and number in subject line); see FOA Sec. VII.A. Problems with ARPA-E eXCHANGE? Email ExchangeHelp@hq.doe.gov (with FOA name and number in subject line).

1. GOVERNMENT USE LICENSE

The U.S. Government retains a nonexclusive, nontransferable, irrevocable, paid-up license to practice or have practiced for or on behalf of the United States any subject invention throughout the world. This license extends to contractors doing work on behalf of the Government.

2. MARCH-IN RIGHTS

The U.S. Government retains march-in rights with respect to all subject inventions. Through “march-in rights,” the Government may require a Prime Recipient or Subrecipient who has elected to retain title to a subject invention (or their assignees or exclusive licensees), to grant a license for use of the invention. In addition, the Government may grant licenses for use of the subject invention when Prime Recipients, Subrecipients, or their assignees and exclusive licensees refuse to do so.

The U.S. Government may exercise its march-in rights if it determines that such action is necessary under any of the four following conditions:

- The owner or licensee has not taken or is not expected to take effective steps to achieve practical application of the invention within a reasonable time;
- The owner or licensee has not taken action to alleviate health or safety needs in a reasonably satisfactory manner;
- The owner has not met public use requirements specified by Federal statutes in a reasonably satisfactory manner; or
- The U.S. Manufacturing requirement has not been met.

C. RIGHTS IN TECHNICAL DATA

Data rights differ based on whether data is first produced under an award or instead was developed at private expense outside the award.

- Background or “Limited Rights Data”: The U.S. Government will not normally require delivery of technical data developed solely at private expense prior to issuance of an award, except as necessary to monitor technical progress and evaluate the potential of proposed technologies to reach specific technical and cost metrics.
- Generated Data: The U.S. Government normally retains very broad rights in technical data produced under Government financial assistance awards, including the right to distribute to the public. However, pursuant to special statutory authority, certain categories of data generated under ARPA-E awards may be protected from public disclosure for up to for up to ten years (or more, if approved by ARPA-E) in accordance with provisions that will be set forth in the award. In addition, invention disclosures may be protected from public disclosure for a reasonable time in order to allow for filing a patent application.

D. PROTECTED PERSONALLY IDENTIFIABLE INFORMATION

Applicants may not include any Protected Personally Identifiable Information (Protected PII) in their submissions to ARPA-E. Protected PII is defined as data that, if compromised, could cause harm to an individual such as identity theft. Listed below are examples of Protected PII that Applicants must not include in their submissions.

- Social Security Numbers in any form;
- Place of Birth associated with an individual;
- Date of Birth associated with an individual;
- Mother's maiden name associated with an individual;
- Biometric record associated with an individual;
- Fingerprint;
- Iris scan;
- DNA;
- Medical history information associated with an individual;
- Medical conditions, including history of disease;
- Metric information, e.g. weight, height, blood pressure;
- Criminal history associated with an individual;
- Ratings;
- Disciplinary actions;
- Performance elements and standards (or work expectations) are PII when they are so intertwined with performance appraisals that their disclosure would reveal an individual's performance appraisal;
- Financial information associated with an individual;
- Credit card numbers;
- Bank account numbers; and
- Security clearance history or related information (not including actual clearances held).

E. FOAs AND FOA MODIFICATIONS

FOAs are posted on ARPA-E eXCHANGE (<https://arpa-e-foa.energy.gov/>), Grants.gov (<http://www.grants.gov/>), and FedConnect (<https://www.fedconnect.net/FedConnect/>). Any modifications to the FOA are also posted to these websites. You can receive an e-mail when a modification is posted by registering with FedConnect as an interested party for this FOA. It is recommended that you register as soon as possible after release of the FOA to ensure that you receive timely notice of any modifications or other announcements. More information is available at <https://www.fedconnect.net>.

F. OBLIGATION OF PUBLIC FUNDS

The Contracting Officer is the only individual who can make awards on behalf of ARPA-E or obligate ARPA-E to the expenditure of public funds. A commitment or obligation by any individual other than the Contracting Officer, either explicit or implied, is invalid.

Questions about this FOA? Check the Frequently Asked Questions available at <http://arpa-e.energy.gov/faq>. For questions that have not already been answered, email ARPA-E-CO@hq.doe.gov (with FOA name and number in subject line); see FOA Sec. VII.A. Problems with ARPA-E eXCHANGE? Email ExchangeHelp@hq.doe.gov (with FOA name and number in subject line).

ARPA-E awards may not be transferred, assigned, or assumed without the prior written consent of a Contracting Officer.

G. REQUIREMENT FOR FULL AND COMPLETE DISCLOSURE

Applicants are required to make a full and complete disclosure of the information requested in the Business Assurances & Disclosures Form. Disclosure of the requested information is mandatory. Any failure to make a full and complete disclosure of the requested information may result in:

- The rejection of a Concept Paper, Full Application, and/or Reply to Reviewer Comments;
- The termination of award negotiations;
- The modification, suspension, and/or termination of a funding agreement;
- The initiation of debarment proceedings, debarment, and/or a declaration of ineligibility for receipt of Federal contracts, subcontracts, and financial assistance and benefits; and
- Civil and/or criminal penalties.

H. RETENTION OF SUBMISSIONS

ARPA-E expects to retain copies of all Concept Papers, Full Applications, Replies to Reviewer Comments, and other submissions. No submissions will be returned. By applying to ARPA-E for funding, Applicants consent to ARPA-E's retention of their submissions.

I. MARKING OF CONFIDENTIAL INFORMATION

ARPA-E will use data and other information contained in Concept Papers, Full Applications, and Replies to Reviewer Comments strictly for evaluation purposes.

Concept Papers, Full Applications, Replies to Reviewer Comments, and other submissions containing confidential, proprietary, or privileged information should be marked as described below. Failure to comply with these marking requirements may result in the disclosure of the unmarked information under the Freedom of Information Act or otherwise. The U.S. Government is not liable for the disclosure or use of unmarked information, and may use or disclose such information for any purpose.

The cover sheet of the Concept Paper, Full Application, Reply to Reviewer Comments, or other submission must be marked as follows and identify the specific pages containing confidential, proprietary, or privileged information:

Questions about this FOA? Check the Frequently Asked Questions available at <http://arpa-e.energy.gov/faq>. For questions that have not already been answered, email ARPA-E-CO@hq.doe.gov (with FOA name and number in subject line); see FOA Sec. VII.A. Problems with ARPA-E eXCHANGE? Email ExchangeHelp@hq.doe.gov (with FOA name and number in subject line).

Notice of Restriction on Disclosure and Use of Data:

Pages [] of this document may contain confidential, proprietary, or privileged information that is exempt from public disclosure. Such information shall be used or disclosed only for evaluation purposes or in accordance with a financial assistance or loan agreement between the submitter and the Government. The Government may use or disclose any information that is not appropriately marked or otherwise restricted, regardless of source.

The header and footer of every page that contains confidential, proprietary, or privileged information must be marked as follows: "Contains Confidential, Proprietary, or Privileged Information Exempt from Public Disclosure." In addition, every line and paragraph containing proprietary, privileged, or trade secret information must be clearly marked with double brackets or highlighting.

J. COMPLIANCE AUDIT REQUIREMENT

A prime recipient organized as a for-profit entity expending \$750,000 or more of DOE funds in the entity's fiscal year (including funds expended as a Subrecipient) must have an annual compliance audit performed at the completion of its fiscal year. For additional information, refer to Subpart F of: (i) 2 C.F.R. Part 200, and (ii) 2 C.F.R. Part 910.

If an educational institution, non-profit organization, or state/local government is either a Prime Recipient or a Subrecipient, and has expended \$750,000 or more of Federal funds in the entity's fiscal year, the entity must have an annual compliance audit performed at the completion of its fiscal year. For additional information refer to Subpart F of 2 C.F.R. Part 200.

K. EXPORT CONTROL

The United States government regulates the transfer of information, commodities, technology, and software considered to be strategically important to the United States to protect national security, foreign policy, and economic interests without imposing undue regulatory burdens on legitimate international trade. There is a network of federal agencies and regulations that govern exports that are collectively referred to as "Export Controls". All Prime Recipients and subrecipients are responsible for ensuring compliance with all applicable United States Export Control laws and regulations relating to any work performed under a resulting award.

Each Prime Recipient will be required to immediately report to DOE any export control violations related to the project funded under the DOE award, at the recipient or subrecipient level, and provide the corrective action(s) to prevent future violations.

VIII. GLOSSARY

Applicant: The entity that submits the application to ARPA-E. In the case of a Project Team, the Applicant is the lead organization listed on the application.

Application: The entire submission received by ARPA-E, including the Preliminary Application, Full Application, Reply to Reviewer Comments, and Small Business Grant Application (if applicable).

ARPA-E: is the Advanced Research Projects Agency – Energy, an agency of the U.S. Department of Energy.

Cost Sharing: Is the portion of project costs from non-Federal sources that are borne by the Prime Recipient (or non-Federal third parties on behalf of the Prime Recipient), rather than by the Federal Government.

Covered Individual: an individual who contributes in a substantive, meaningful way to the scientific development or execution of an R&D project proposed to be carried out with a award from DOE, i.e. senior/key personnel. ARPA-E may further designate covered individuals during award negotiations or the award period of performance.

Deliverable: A deliverable is the quantifiable goods or services that will be provided upon the successful completion of a project task or sub-task.

DOE: U.S. Department of Energy

DOE/NNSA: U.S. Department of Energy/National Nuclear Security Administration.

FFRDCs: Federally Funded Research and Development Centers

FOA: Funding Opportunity Announcement

Foreign Affiliation: a funded or unfunded academic, professional, or institutional appointment or position with a foreign government or government-owned entity, whether full-time, part-time, or voluntary (including adjunct, visiting, or honorary).

Foreign Countries of Concern: the People’s Republic of China, the Democratic People’s Republic of Korea, the Russian Federation, the Islamic Republic of Iran, Burma, Eritrea, Pakistan, Saudi Arabia, Tajikistan, and Turkmenistan.

For-Profit Organizations (Other than Small Businesses) (or large businesses): Means entities organized for-profit other than small businesses as defined elsewhere in this Glossary.

GOCOs: U.S. Government Owned, Contractor Operated laboratories.

Questions about this FOA? Check the Frequently Asked Questions available at <http://arpa-e.energy.gov/faq>. For questions that have not already been answered, email ARPA-E-CO@hq.doe.gov (with FOA name and number in subject line); see FOA Sec. VII.A. Problems with ARPA-E eXCHANGE? Email ExchangeHelp@hq.doe.gov (with FOA name and number in subject line).

GOGOs: U.S. Government Owned, Government Operated laboratories.

Institutions of Higher Education (or *educational institutions*): Has the meaning set forth at 20 U.S.C. 1001.

Malign Foreign Talent Recruitment Program: the meaning given such term in section 10638 of the Research and Development, Competition, and Innovation Act (division B of Public Law 117–167) or 42 USC 19237, as of October 20, 2022.

Milestone: A milestone is the tangible, observable measurement that will be provided upon the successful completion of a project task or sub-task.

Nonprofit Organizations (or *nonprofits*): Has the meaning set forth at 2 C.F.R. § 200.70.

Prime Recipient: The signatory to the funding agreement with ARPA-E.

PI: Principal Investigator.

Project Team: A Project Team consists of the Prime Recipient, Subrecipients, and others performing or otherwise supporting work under an ARPA-E funding agreement.

Small Business: Small businesses are domestically incorporated entities that meet the criteria established by the U.S. Small Business Administration’s (SBA) “Table of Small Business Size Standards Matched to North American Industry Classification System Codes” (NAICS) (<http://www.sba.gov/content/small-business-size-standards>).

Standalone Applicant: An Applicant that applies for funding on its own, not as part of a Project Team.

Subject Invention: Any invention conceived or first actually reduced to practice under an ARPA-E funding agreement.

Subrecipient: An entity (not an individual) that receives a subaward from the Prime Recipient to carry out part of the ARPA-E award.

Task: A task is an operation or segment of the work plan that requires both effort and resources. Each task (or sub-task) is connected to the overall objective of the project, via the achievement of a milestone or a deliverable.

Total Project Cost: The sum of the Prime Recipient share and the Federal Government share of total allowable costs. The Federal Government share generally includes costs incurred by GOGOs, FFRDCs, and GOCOs.

TT&O: Technology Transfer and Outreach. (See Section IV.G.8 of the FOA for more information).

Questions about this FOA? Check the Frequently Asked Questions available at <http://arpa-e.energy.gov/faq>. For questions that have not already been answered, email ARPA-E-CO@hq.doe.gov (with FOA name and number in subject line); see FOA Sec. VII.A. Problems with ARPA-E eXCHANGE? Email ExchangeHelp@hq.doe.gov (with FOA name and number in subject line).