

**FINANCIAL ASSISTANCE  
FUNDING OPPORTUNITY ANNOUNCEMENT**



**ADVANCED RESEARCH PROJECTS AGENCY – ENERGY (ARPA-E)  
U.S. DEPARTMENT OF ENERGY**

**ENERGY-EFFICIENT LIGHT-WAVE INTEGRATED TECHNOLOGY  
ENABLING NETWORKS THAT ENHANCE DATACENTERS  
(ENLITENED)**

Announcement Type: **Initial Announcement Modification 01**  
Funding Opportunity No. DE-FOA-0001566  
CFDA Number 81.135

<b>Funding Opportunity Announcement (FOA) Issue Date:</b>	Friday, June 10, 2016
<b>First Deadline for Questions to <a href="mailto:ARPA-E-CO@hq.doe.gov">ARPA-E-CO@hq.doe.gov</a>:</b>	5 PM ET, Friday July 15, 2016
<b>Submission Deadline for Concept Papers:</b>	5 PM ET, Monday July 25, 2016
<b>Second Deadline for Questions to <a href="mailto:ARPA-E-CO@hq.doe.gov">ARPA-E-CO@hq.doe.gov</a>:</b>	5 PM ET, <b>TBD Friday, October 21, 2016</b>
<b>Submission Deadline for Full Applications:</b>	5 PM ET, <b>TBD Monday, October 31, 2016</b>
<b>Submission Deadline for Replies to Reviewer Comments:</b>	5 PM ET, <b>TBD Friday, December 16, 2016</b>
<b>Expected Date for Selection Notifications:</b>	<b>TBD January 2017</b>
<b>Total Amount to Be Awarded</b>	Approximately \$25 million, subject to the availability of appropriated funds.
<b>Anticipated Awards</b>	ARPA-E may issue one, multiple, or no awards under this FOA. Awards may vary between \$250,000 and \$10 million.

- For eligibility criteria, see Section III.A of the FOA.
- For cost share requirements under this FOA, see Section III.B of the FOA.
- To apply to this FOA, Applicants must register with and submit application materials through ARPA-E eXCHANGE (<https://arpa-e-foa.energy.gov/Registration.aspx>). For detailed guidance on using ARPA-E eXCHANGE, see Section IV.H.1 of the FOA.
- Applicants are responsible for meeting each submission deadline. Applicants are strongly encouraged to submit their applications at least 48 hours in advance of the submission deadline.

*Questions about this FOA? Check the Frequently Asked Questions available at <http://arpa-e.energy.gov/faq>. For questions that have not already been answered, email [ARPA-E-CO@hq.doe.gov](mailto:ARPA-E-CO@hq.doe.gov) (with FOA name and number in subject line); see FOA Sec. VII.A. Problems with ARPA-E eXCHANGE? Email [ExchangeHelp@hq.doe.gov](mailto:ExchangeHelp@hq.doe.gov) (with FOA name and number in subject line).*

- For detailed guidance on compliance and responsiveness criteria, see Sections III.C.1 through III.C.4 of the FOA.

*Questions about this FOA? Check the Frequently Asked Questions available at <http://arpa-e.energy.gov/faq>. For questions that have not already been answered, email [ARPA-E-CO@hq.doe.gov](mailto:ARPA-E-CO@hq.doe.gov) (with FOA name and number in subject line); see FOA Sec. VII.A. Problems with ARPA-E eXCHANGE? Email [ExchangeHelp@hq.doe.gov](mailto:ExchangeHelp@hq.doe.gov) (with FOA name and number in subject line).*

## **MODIFICATIONS**

All modifications to the Funding Opportunity Announcement (FOA) are highlighted in yellow in the body of the FOA.

<b>Mod. No.</b>	<b>Date</b>	<b>Description of Modifications</b>
<b>01</b>	<b>9/19/2016</b>	<ul style="list-style-type: none"> <li>• Inserted certain deadlines, including the deadlines for submitting questions and Full Applications. See Cover Page and Required Documents Checklist.</li> <li>• Clarified Budget and Instructions, see Section I.D of the FOA.</li> <li>• Clarified Technical Performance Targets and Deliverables, see Section I.E of the FOA.</li> <li>• Revised Award Overview Information, see Section II.A of the FOA.</li> <li>• Revised approximate number of days to submit a Full Application, See Section IV.A.3 of the FOA.</li> <li>• Revised the following sections of the FOA to provide guidance on required application forms and the content and form of Full Applications and Replies to Reviewer Comments: Required Documents Checklist and Sections IV.D, IV.E, and IV.G of the FOA. Applicants are strongly encouraged to use the templates provided on ARPA-E eXCHANGE (<a href="https://arpa-e-foa.energy.gov">https://arpa-e-foa.energy.gov</a>).</li> <li>• Inserted criteria that ARPA-E will use to evaluate Full Applications, see Section V.A.2 of the FOA.</li> <li>• Inserted criteria that ARPA-E will use to evaluate Replies to Reviewer Comments in Section V.A.3 of the FOA.</li> <li>• Clarified Program Policy Factors to include the U.S. Manufacturing Plan under Relevance to ARPA-E Mission Advancement, see Section V.B.1 of the FOA.</li> <li>• Inserted information on the anticipated announcement and award dates, see Section V.C of the FOA.</li> <li>• Inserted information concerning Full Application Notifications, see Section VI.A.3 of the FOA.</li> <li>• Inserted Administrative and National Policy Requirements, see Section VI.B of the FOA.</li> <li>• Inserted Reporting Requirements, see Section VI.C of the FOA.</li> <li>• Inserted Determination of Exceptional Circumstances (DEC) Requirement, see Section VIII.F of the FOA.</li> </ul>

Questions about this FOA? Check the Frequently Asked Questions available at <http://arpa-e.energy.gov/faq>. For questions that have not already been answered, email [ARPA-E-CO@hq.doe.gov](mailto:ARPA-E-CO@hq.doe.gov) (with FOA name and number in subject line); see FOA Sec. VII.A. Problems with ARPA-E eXCHANGE? Email [ExchangeHelp@hq.doe.gov](mailto:ExchangeHelp@hq.doe.gov) (with FOA name and number in subject line).

**TABLE OF CONTENTS**

**REQUIRED DOCUMENTS CHECKLIST** ..... - 1 -

**I. FUNDING OPPORTUNITY DESCRIPTION** ..... - 3 -

**A. AGENCY OVERVIEW** ..... - 3 -

**B. PROGRAM OVERVIEW** ..... - 4 -

        1. *SUMMARY* ..... - 4 -

        2. *BACKGROUND AND MOTIVATION* ..... - 5 -

**C. PROGRAM OBJECTIVES** ..... - 12 -

**D. PROGRAM STRUCTURE AND TECHNICAL CATEGORIES OF INTEREST** ..... - 13 -

**E. TECHNICAL PERFORMANCE TARGETS AND DELIVERABLES** ..... - 14 -

**II. AWARD INFORMATION** ..... - 19 -

**A. AWARD OVERVIEW** ..... - 19 -

**B. ARPA-E FUNDING AGREEMENTS** ..... - 20 -

        1. *COOPERATIVE AGREEMENTS* ..... - 20 -

        2. *FUNDING AGREEMENTS WITH FFRDCs/DOE LABS, GOGOS, AND FEDERAL INSTRUMENTALITIES* ..... - 20 -

        3. *TECHNOLOGY INVESTMENT AGREEMENTS* ..... - 21 -

**C. STATEMENT OF SUBSTANTIAL INVOLVEMENT** ..... - 22 -

**III. ELIGIBILITY INFORMATION** ..... - 23 -

**A. ELIGIBLE APPLICANTS** ..... - 23 -

        1. *INDIVIDUALS* ..... - 23 -

        2. *DOMESTIC ENTITIES* ..... - 23 -

        3. *FOREIGN ENTITIES* ..... - 23 -

        4. *CONSORTIUM ENTITIES* ..... - 24 -

**B. COST SHARING** ..... - 24 -

        1. *BASE COST SHARE REQUIREMENT* ..... - 25 -

        2. *INCREASED COST SHARE REQUIREMENT* ..... - 25 -

        3. *REDUCED COST SHARE REQUIREMENT* ..... - 25 -

        4. *LEGAL RESPONSIBILITY* ..... - 26 -

        5. *COST SHARE ALLOCATION* ..... - 26 -

        6. *COST SHARE TYPES AND ALLOWABILITY* ..... - 27 -

        7. *COST SHARE CONTRIBUTIONS BY FFRDCs AND GOGOS* ..... - 28 -

        8. *COST SHARE VERIFICATION* ..... - 28 -

**C. OTHER** ..... - 28 -

        1. *COMPLIANT CRITERIA* ..... - 28 -

        2. *RESPONSIVENESS CRITERIA* ..... - 29 -

        3. *SUBMISSIONS SPECIFICALLY NOT OF INTEREST* ..... - 30 -

        4. *LIMITATION ON NUMBER OF SUBMISSIONS* ..... - 31 -

**IV. APPLICATION AND SUBMISSION INFORMATION** ..... - 31 -

**A. APPLICATION PROCESS OVERVIEW** ..... - 31 -

        1. *REGISTRATION IN ARPA-E eXCHANGE* ..... - 31 -

Questions about this FOA? Check the Frequently Asked Questions available at <http://arpa-e.energy.gov/faq>. For questions that have not already been answered, email [ARPA-E-CO@hq.doe.gov](mailto:ARPA-E-CO@hq.doe.gov) (with FOA name and number in subject line); see FOA Sec. VII.A. Problems with ARPA-E eXCHANGE? Email [ExchangeHelp@hq.doe.gov](mailto:ExchangeHelp@hq.doe.gov) (with FOA name and number in subject line).

2.	CONCEPT PAPERS .....	- 31 -
3.	FULL APPLICATIONS .....	- 32 -
4.	REPLY TO REVIEWER COMMENTS .....	- 32 -
5.	PRE-SELECTION CLARIFICATIONS AND "DOWN-SELECT" PROCESS .....	- 32 -
6.	SELECTION FOR AWARD NEGOTIATIONS .....	- 32 -
7.	MANDATORY WEBINAR .....	- 33 -
B.	APPLICATION FORMS .....	- 33 -
C.	CONTENT AND FORM OF CONCEPT PAPERS .....	- 33 -
1.	CONCEPT PAPER .....	- 34 -
A.	CONCEPT SUMMARY .....	- 34 -
B.	INNOVATION AND IMPACT .....	- 35 -
C.	PROPOSED WORK .....	- 35 -
D.	TEAM ORGANIZATION AND CAPABILITIES .....	- 35 -
D.	CONTENT AND FORM OF FULL APPLICATIONS .....	- 36 -
1.	FIRST COMPONENT: TECHNICAL VOLUME .....	- 37 -
2.	SECOND COMPONENT: SF-424 .....	- 44 -
3.	THIRD COMPONENT: BUDGET JUSTIFICATION WORKBOOK/SF-424A .....	- 45 -
4.	FOURTH COMPONENT: SUMMARY FOR PUBLIC RELEASE .....	- 46 -
5.	FIFTH COMPONENT: SUMMARY SLIDE .....	- 46 -
6.	SIXTH COMPONENT: BUSINESS ASSURANCES & DISCLOSURES FORM .....	- 47 -
7.	SEVENTH COMPONENT: U.S. MANUFACTURING PLAN .....	- 48 -
E.	CONTENT AND FORM OF REPLIES TO REVIEWER COMMENTS .....	- 49 -
F.	INTERGOVERNMENTAL REVIEW .....	- 50 -
G.	FUNDING RESTRICTIONS .....	- 50 -
1.	ALLOWABLE COSTS .....	- 50 -
2.	PRE-AWARD COSTS .....	- 50 -
3.	PATENT COSTS .....	- 51 -
4.	CONSTRUCTION .....	- 51 -
5.	FOREIGN TRAVEL .....	- 51 -
6.	PERFORMANCE OF WORK IN THE UNITED STATES .....	- 51 -
7.	PURCHASE OF NEW EQUIPMENT .....	- 52 -
8.	TECHNOLOGY TRANSFER AND OUTREACH .....	- 52 -
9.	LOBBYING .....	- 53 -
10.	CONFERENCE SPENDING .....	- 54 -
11.	INDEPENDENT RESEARCH AND DEVELOPMENT COSTS .....	- 54 -
H.	OTHER SUBMISSION REQUIREMENTS .....	- 54 -
1.	USE OF ARPA-E eXCHANGE .....	- 54 -
V.	APPLICATION REVIEW INFORMATION .....	- 55 -
A.	CRITERIA .....	- 55 -
1.	CRITERIA FOR CONCEPT PAPERS .....	- 56 -
2.	CRITERIA FOR FULL APPLICATIONS .....	- 57 -
3.	CRITERIA FOR REPLIES TO REVIEWER COMMENTS .....	- 58 -
B.	REVIEW AND SELECTION PROCESS .....	- 59 -
1.	PROGRAM POLICY FACTORS .....	- 59 -
2.	ARPA-E REVIEWERS .....	- 60 -

Questions about this FOA? Check the Frequently Asked Questions available at <http://arpa-e.energy.gov/faq>. For questions that have not already been answered, email [ARPA-E-CO@hq.doe.gov](mailto:ARPA-E-CO@hq.doe.gov) (with FOA name and number in subject line); see FOA Sec. VII.A. Problems with ARPA-E eXCHANGE? Email [ExchangeHelp@hq.doe.gov](mailto:ExchangeHelp@hq.doe.gov) (with FOA name and number in subject line).

3.	<b>ARPA-E SUPPORT CONTRACTOR</b> .....	- 60 -
C.	<b>ANTICIPATED ANNOUNCEMENT AND AWARD DATES</b> .....	- 60 -
VI.	<b>AWARD ADMINISTRATION INFORMATION</b> .....	- 61 -
A.	<b>AWARD NOTICES</b> .....	- 61 -
1.	<b>REJECTED SUBMISSIONS</b> .....	- 61 -
2.	<b>CONCEPT PAPER NOTIFICATIONS</b> .....	- 61 -
3.	<b>FULL APPLICATION NOTIFICATIONS</b> .....	- 61 -
B.	<b>ADMINISTRATIVE AND NATIONAL POLICY REQUIREMENTS</b> .....	- 62 -
1.	<b>DUNS NUMBER AND SAM, FSRS, AND FEDCONNECT REGISTRATIONS</b> .....	- 63 -
2.	<b>NATIONAL POLICY ASSURANCES</b> .....	- 63 -
3.	<b>PROOF OF COST SHARE COMMITMENT AND ALLOWABILITY</b> .....	- 64 -
4.	<b>COST SHARE PAYMENTS</b> .....	- 64 -
5.	<b>ENVIRONMENTAL IMPACT QUESTIONNAIRE</b> .....	- 64 -
6.	<b>TECHNOLOGY-TO-MARKET PLAN</b> .....	- 65 -
7.	<b>INTELLECTUAL PROPERTY AND DATA MANAGEMENT PLANS</b> .....	- 65 -
8.	<b>U.S. MANUFACTURING REQUIREMENT</b> .....	- 66 -
9.	<b>CORPORATE FELONY CONVICTIONS AND FEDERAL TAX LIABILITY</b> .....	- 67 -
10.	<b>APPLICANT RISK ANALYSIS</b> .....	- 68 -
11.	<b>RECIPIENT INTEGRITY AND PERFORMANCE MATTERS</b> .....	- 68 -
12.	<b>NONDISCLOSURE AND CONFIDENTIALITY AGREEMENTS REPRESENTATIONS</b> .....	- 68 -
C.	<b>REPORTING</b> .....	- 69 -
VII.	<b>AGENCY CONTACTS</b> .....	- 69 -
A.	<b>COMMUNICATIONS WITH ARPA-E</b> .....	- 69 -
B.	<b>DEBRIEFINGS</b> .....	- 70 -
VIII.	<b>OTHER INFORMATION</b> .....	- 71 -
A.	<b>FOAs AND FOA MODIFICATIONS</b> .....	- 71 -
B.	<b>OBLIGATION OF PUBLIC FUNDS</b> .....	- 71 -
C.	<b>REQUIREMENT FOR FULL AND COMPLETE DISCLOSURE</b> .....	- 71 -
D.	<b>RETENTION OF SUBMISSIONS</b> .....	- 72 -
E.	<b>MARKING OF CONFIDENTIAL INFORMATION</b> .....	- 72 -
F.	<b>TITLE TO SUBJECT INVENTIONS</b> .....	- 72 -
G.	<b>GOVERNMENT RIGHTS IN SUBJECT INVENTIONS</b> .....	- 73 -
1.	<b>GOVERNMENT USE LICENSE</b> .....	- 74 -
2.	<b>MARCH-IN RIGHTS</b> .....	- 74 -
3.	<b>U.S. MANUFACTURING REQUIREMENT</b> .....	- 74 -
H.	<b>RIGHTS IN TECHNICAL DATA</b> .....	- 74 -
I.	<b>PROTECTED PERSONALLY IDENTIFIABLE INFORMATION</b> .....	- 75 -
J.	<b>COMPLIANCE AUDIT REQUIREMENT</b> .....	- 76 -
IX.	<b>REFERENCES</b> .....	- 76 -
X.	<b>GLOSSARY</b> .....	- 77 -

Questions about this FOA? Check the Frequently Asked Questions available at <http://arpa-e.energy.gov/faq>. For questions that have not already been answered, email [ARPA-E-CO@hq.doe.gov](mailto:ARPA-E-CO@hq.doe.gov) (with FOA name and number in subject line); see FOA Sec. VII.A. Problems with ARPA-E eXCHANGE? Email [ExchangeHelp@hq.doe.gov](mailto:ExchangeHelp@hq.doe.gov) (with FOA name and number in subject line).

Questions about this FOA? Check the Frequently Asked Questions available at <http://arpa-e.energy.gov/faq>. For questions that have not already been answered, email [ARPA-E-CO@hq.doe.gov](mailto:ARPA-E-CO@hq.doe.gov) (with FOA name and number in subject line); see FOA Sec. VII.A. Problems with ARPA-E eXCHANGE? Email [ExchangeHelp@hq.doe.gov](mailto:ExchangeHelp@hq.doe.gov) (with FOA name and number in subject line).

**REQUIRED DOCUMENTS CHECKLIST**

For an overview of the application process, see Section IV.A of the FOA.

For guidance regarding requisite application forms, see Section IV.B of the FOA.

For guidance regarding the content and form of Concept Papers, Full Applications, and Replies to Reviewer Comments, see Sections IV.C, IV.D, and IV.E of the FOA.

SUBMISSION	COMPONENTS	OPTIONAL/ MANDATORY	FOA SECTION	DEADLINE
Concept Paper	<ul style="list-style-type: none"> <li>• Each Applicant must submit a Concept Paper in Adobe PDF format by the stated deadline. The Concept Paper must not exceed 4 pages in length and must include the following:                             <ul style="list-style-type: none"> <li>○ Concept Summary</li> <li>○ Innovation and Impact</li> <li>○ Proposed Work</li> <li>○ Team Organization and Capabilities</li> </ul> </li> </ul>	Mandatory	IV.C	5 PM ET, Monday July 25, 2016
Full Application	<p><b>[TO BE INSERTED BY FOA MODIFICATION IN SEPTEMBER 2016]</b></p> <ul style="list-style-type: none"> <li>• Each Applicant must submit a Technical Volume in Adobe PDF format by the stated deadline. Applicants may use the Technical Volume template available on ARPA-E eXCHANGE (<a href="https://arpa-e-foa.energy.gov">https://arpa-e-foa.energy.gov</a>). The Technical Volume must include the following:                             <ul style="list-style-type: none"> <li>○ Executive Summary (1 page max.)</li> <li>○ Sections 1-5 (30 pages max.)                                     <ul style="list-style-type: none"> <li>• 1. Innovation and Impact</li> <li>• 2. Proposed Work</li> <li>• 3. Team Organization and Capabilities</li> <li>• 4. Technology to Market</li> <li>• 5. Budget</li> </ul> </li> <li>○ Bibliographic References (no page limit)</li> <li>○ Personal Qualification Summaries (each PQS limited to 3 pages in length, no cumulative page limit)</li> </ul> </li> <li>• The Technical Volume must be accompanied by:                             <ul style="list-style-type: none"> <li>○ SF-424 (no page limit, Adobe PDF format);</li> <li>○ Budget Justification Workbook/SF424A (no page limit, Microsoft Excel format)</li> <li>○ Summary for Public Release (250 words max., Adobe PDF format);</li> <li>○ Summary Slide (1 page limit, Microsoft PowerPoint format) – Applicants may use the Summary Slide template available on ARPA-E eXCHANGE (<a href="https://arpa-e-foa.energy.gov">https://arpa-e-foa.energy.gov</a>); and</li> </ul> </li> </ul>	Mandatory	IV.D	5 PM ET, <del>TBD</del> Monday, October 31, 2016

Questions about this FOA? Check the Frequently Asked Questions available at <http://arpa-e.energy.gov/faq>. For questions that have not already been answered, email [ARPA-E-CO@hq.doe.gov](mailto:ARPA-E-CO@hq.doe.gov) (with FOA name and number in subject line); see FOA Sec. VII.A. Problems with ARPA-E eXCHANGE? Email [ExchangeHelp@hq.doe.gov](mailto:ExchangeHelp@hq.doe.gov) (with FOA name and number in subject line).



	<ul style="list-style-type: none"><li>○ Completed and signed Business Assurances &amp; Disclosures Form (no page limit, Adobe PDF format).</li><li>○ U.S. Manufacturing Plan (1 page limit, Adobe PDF format)</li></ul>			
Reply to Reviewer Comments	<p>[TO BE INSERTED BY FOA MODIFICATION IN SEPTEMBER 2016]</p> <ul style="list-style-type: none"><li>• Each Applicant may submit a Reply to Reviewer Comments in Adobe PDF format. This submission is optional. Applicants may use the Reply to Reviewer Comments template available on ARPA-E eXCHANGE (<a href="https://arpa-e-foa.energy.gov">https://arpa-e-foa.energy.gov</a>). The Reply may include:<ul style="list-style-type: none"><li>○ Up to 2 pages of text; and</li><li>○ Up to 1 page of images.</li></ul></li></ul>	Optional	IV.E	5 PM ET, TBD Friday, December 16, 2016

Questions about this FOA? Check the Frequently Asked Questions available at <http://arpa-e.energy.gov/faq>. For questions that have not already been answered, email [ARPA-E-CO@hq.doe.gov](mailto:ARPA-E-CO@hq.doe.gov) (with FOA name and number in subject line); see FOA Sec. VII.A. Problems with ARPA-E eXCHANGE? Email [ExchangeHelp@hq.doe.gov](mailto:ExchangeHelp@hq.doe.gov) (with FOA name and number in subject line).

## I. FUNDING OPPORTUNITY DESCRIPTION

### A. AGENCY OVERVIEW

The Advanced Research Projects Agency – Energy (ARPA-E), an organization within the Department of Energy (DOE), is chartered by Congress in the America COMPETES Act of 2007 (P.L. 110-69), as amended by the America COMPETES Reauthorization Act of 2010 (P.L. 111-358) to:

- “(A) to enhance the economic and energy security of the United States through the development of energy technologies that result in—
- (i) reductions of imports of energy from foreign sources;
  - (ii) reductions of energy-related emissions, including greenhouse gases; and
  - (iii) improvement in the energy efficiency of all economic sectors; and
- (B) to ensure that the United States maintains a technological lead in developing and deploying advanced energy technologies.”

ARPA-E issues this Funding Opportunity Announcement (FOA) under the programmatic authorizing statute codified at 42 U.S.C. § 16538. The FOA and any awards made under this FOA are subject to 2 C.F.R. Part 200 as amended by 2 C.F.R. Part 910.

ARPA-E funds research on and the development of high-potential, high-impact energy technologies that are too early for private-sector investment. The agency focuses on technologies that can be meaningfully advanced with a modest investment over a defined period of time in order to catalyze the translation from scientific discovery to early-stage technology. For the latest news and information about ARPA-E, its programs and the research projects currently supported, see: <http://arpa-e.energy.gov/>.

**ARPA-E funds transformational research.** Existing energy technologies generally progress on established “learning curves” where refinements to a technology and the economies of scale that accrue as manufacturing and distribution develop drive down the cost/performance metric in a gradual fashion. This continual improvement of a technology is important to its increased commercial deployment and is appropriately the focus of the private sector or the applied technology offices within DOE. By contrast, ARPA-E supports transformative research that has the potential to create fundamentally new learning curves. ARPA-E technology projects typically start with cost/performance estimates well above the level of an incumbent technology. Given the high risk inherent in these projects, many will fail to progress, but some may succeed in generating a new learning curve with a projected cost/performance metric that is significantly lower than that of the incumbent technology.

**ARPA-E funds technology with the potential to be disruptive in the marketplace.** The mere creation of a new learning curve does not ensure market penetration. Rather, the ultimate value of a technology is determined by the marketplace, and impactful technologies ultimately

Questions about this FOA? Check the Frequently Asked Questions available at <http://arpa-e.energy.gov/faq>. For questions that have not already been answered, email [ARPA-E-CO@hq.doe.gov](mailto:ARPA-E-CO@hq.doe.gov) (with FOA name and number in subject line); see FOA Sec. VII.A. Problems with ARPA-E eXCHANGE? Email [ExchangeHelp@hq.doe.gov](mailto:ExchangeHelp@hq.doe.gov) (with FOA name and number in subject line).

become disruptive – that is, they are widely adopted and displace existing technologies from the marketplace or create entirely new markets. ARPA-E understands that definitive proof of market disruption takes time, particularly for energy technologies. Therefore, ARPA-E funds the development of technologies that, if technically successful, have the clear disruptive potential, e.g., by demonstrating capability for manufacturing at competitive cost and deployment at scale.

**ARPA-E funds applied research and development.** The Office of Management and Budget defines “applied research” as “systematic study to gain knowledge or understanding necessary to determine the means by which a recognized and specific need may be met” and defines “development” as the “systematic application of knowledge or understanding, directed toward the production of useful materials, devices, and systems or methods, including design, development, and improvement of prototypes and new processes to meet specific requirements.”<sup>1</sup> Applicants interested in receiving financial assistance for basic research should contact the DOE’s Office of Science (<http://science.energy.gov/>). Office of Science national scientific user facilities (<http://science.energy.gov/user-facilities/>) are open to all researchers, including ARPA-E applicants and awardees. These facilities provide advanced tools of modern science including accelerators, colliders, supercomputers, light sources and neutron sources, as well as facilities for studying the nanoworld, the environment, and the atmosphere. Projects focused on the improvement of existing technology platforms along defined roadmaps may be appropriate for support through the DOE offices such as: the Office of Energy Efficiency and Renewable Energy (<http://www.eere.energy.gov/>), the Office of Fossil Energy (<http://fossil.energy.gov/>), the Office of Nuclear Energy (<http://www.energy.gov/ne/office-nuclear-energy>), and the Office of Electricity Delivery and Energy Reliability (<http://energy.gov/oe/office-electricity-delivery-and-energy-reliability>).

## **B. PROGRAM OVERVIEW**

### **1. SUMMARY**

The growing demand for datacenter services across a range of applications has resulted in significant and sustained growth in electrical energy consumption in the Information Communications Technology (ICT) sector. Currently, datacenters consume more than 2.5 % of US electricity and this percentage is projected to double in about 8 years [1-4, 6, 7, 9]. Efficiency improvements due to more efficient cooling, power delivery, and electronic processor chips via Moore’s law improve overall efficiency, but do not significantly slow the current growth trend; to do so requires a transformative improvement. The overall objective of the **ENLITENED** (**E**nergy-efficient **L**ight-wave **I**ntegrated **T**echnology **E**nabling **N**etworks that **E**nhance **D**atacenters) program, therefore, is to provide a transformative change - to achieve an overall doubling in datacenter energy efficiency in 10 years through deployment of novel network topologies enabled by integrated photonics technologies. ARPA-E estimates that

---

<sup>1</sup> OMB Circular A-11  
([http://www.whitehouse.gov/sites/default/files/omb/assets/a11\\_current\\_year/a11\\_2014.pdf](http://www.whitehouse.gov/sites/default/files/omb/assets/a11_current_year/a11_2014.pdf)), Section 84, p. 8.

if the technical challenges posed by **ENLITENED** can be overcome, these alone would reduce projected US energy use by about 1% after 10 years and realize at least twice the number of datacenter transactions with the same amount of energy.

Industry projections show that in order to achieve future datacenter performance requirements, metal interconnects must be increasingly replaced by photonic technologies, yet costs for deployment are often prohibitive and energy efficiency is not necessarily the highest priority in the commercial sector [11, 15, 16]. Though a broad industrial consensus pushes toward further photonic integration in switches and other datacenter components [11,16,18], in some cases, large companies will build another 80 MW datacenter to meet demand, rather than increase efficiency with photonics, due to a combination of reliability risks, cost and limited component supply.

To overcome metal interconnect limitations on future datacenter energy-efficiency performance, **ENLITENED** will target the critical packaging and integration challenges needed to exploit the inherent performance advantages of dense photonic interconnects and switching technology at the chip-scale within datacenters. Specifically, **ENLITENED** will target packaging and integration of novel and efficient photonics-enabled hardware systems that can demonstrate at least a 2-fold increase in energy efficiency at the datacenter level. To validate hardware solutions, **ENLITENED** will also entail modeling and simulation of the new datacenter architectures and data traffic protocols under realistic workloads, to provide quantifiable measures to validate transformative design strategies for future datacenters and retrofits.

## 2. BACKGROUND AND MOTIVATION

### Impact on Datacenters: Energy Consumption and Industrial Trends

The energy consumed by datacenters has been the subject of much study [1-5], reaching 91 TWh in 2013, and increasing at a rate that doubles about every 8 years [1]. Currently, datacenters account for about 2.5% of electricity consumption in the US – while the total annual electricity consumption in the US has remained approximately constant at about 3800 TWh [6] from 2005 to 2012<sup>2</sup>.

Datacenters in the US can be divided according to their electricity consumption by market segment as: Small and Medium-Sized (49%), Enterprise/Corporate (27%), Multi-Tenant (19%), Hyper-Scale Cloud Computing (4%), and High Performance Computing (1%) [4] – which shows not only a wide diversity in scale and function, but also highlights the importance of finding energy efficiency solutions that address all market segments. Trends indicate that Multi-Tenant and Cloud services are growing, which may improve efficiencies due to the possibility of virtualizing smaller datacenter functions within larger server farms that allocate resources more efficiently. Nevertheless, the fundamental technologies used, and solutions envisioned are

---

<sup>2</sup> US electrical power generation is projected (EIA reference case) to be 3.9 trillion kWh in 2016, 4.2 in 2026 and 4.7 in 2040. Annual Energy Outlook 2016, early release: <http://www.eia.gov/forecasts/aeo/er/index.cfm>

relevant to all datacenters. With growth in all sectors, the importance for reducing energy consumption across the datacenter application domain continues to grow.

Figure 1 depicts the current and projected trends in aggregate power consumption for datacenters in the US (red line). The demands for datacenter services have resulted in an exponential growth rate in the total power requirement. The exponential growth in service demand is actually outpacing the exponential growth in ICT equipment computing efficiency (due in part to Moore's Law scaling of processor performance). Even more concerning is the trend towards an increasing fraction of datacenter power consumed by the internal datacenter network [17]. This pending upswing in the projected power consumption is attributed to anticipated growth in interconnect energy demands with increasing ICT performance, but with existing network technologies it appears unlikely that network energy efficiency will increase proportionally to server performance. Ultimately, the electrical interconnects to the server chips themselves will not be able to keep up with the increasing computing power of those computing elements [14] – which could potentially add to the energy-efficiency burden of datacenters as depicted in Figure 1 for the years beyond approximately 2022.

As depicted with the dashed green line in Figure 1, the **ENLITENED** Program seeks to suppress this increasing power consumption trend by enabling energy efficient datacenters with packaged integrated photonic interconnects and switches and associated novel networking architectures. Specifically, ARPA-E sees an opportunity to exploit high-density integrated photonic chip-scale I/O at <1 pJ/bit and lower latency network fabrics enabled by integrated photonic links and switching technology. This combination will make possible significant increases in overall system efficiencies and thereby halt the increasing energy demand, and perhaps even lower the aggregate datacenter energy consumption to manageable levels as depicted in Figure 1.

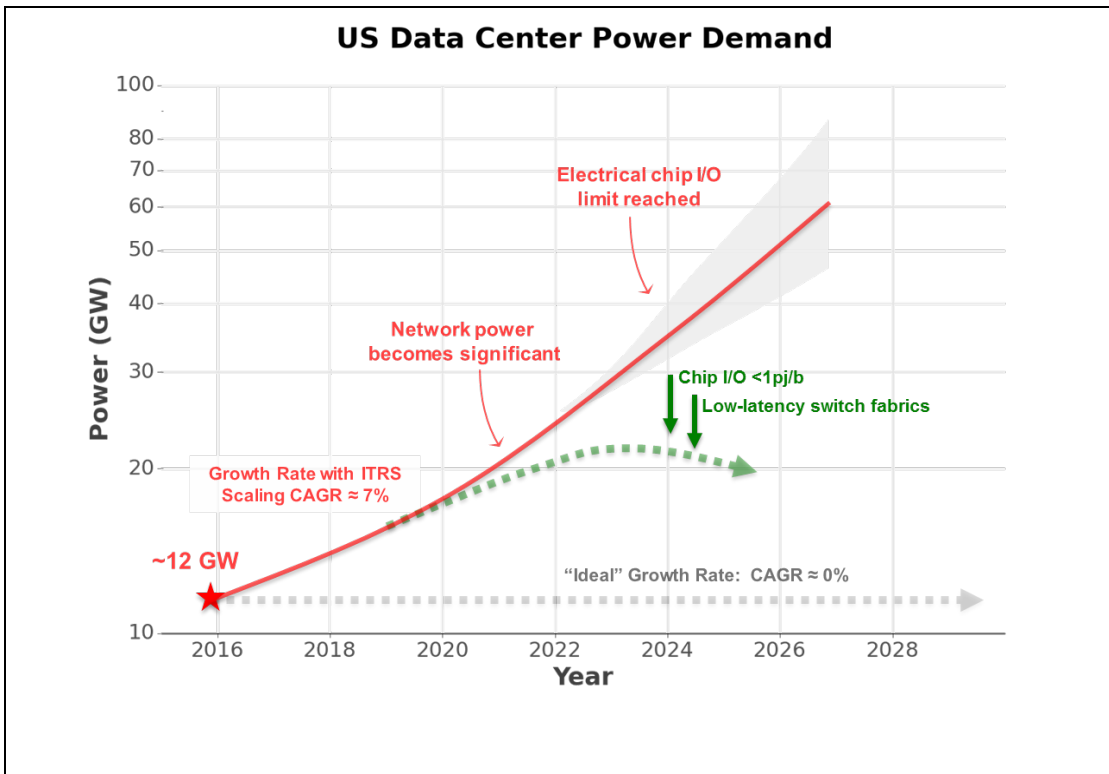

Figure 1. Aggregated power consumption of US datacenters as a function of time. The red line shows current trends and anticipates further electrical power growth due to the network becoming more significant and reaching the limits of metal interconnects. The green dotted line indicates the **ENLITENED** objective enabled by low-energy photonic interconnects and switching technology.<sup>3</sup>

### Rationale for targeting IT Infrastructure vs. other sources of datacenter inefficiency

Opportunities for improving datacenter efficiency abound through potential improvements in Information Technology (IT) components, software, cooling techniques, electrical power delivery, and computing chip advances. As depicted in Figure 2, to analyze the energy consumed by a datacenter, it is useful to break up its energy efficiency into components, for example: electrical power delivery and conversion efficiency, cooling efficiency, and IT efficiency. Currently, power delivery, power down-conversion, and cooling are the subject of much interest and research. For example, companies operating very large datacenters are

<sup>3</sup> The estimated total electrical load of ~12 GW for 2016 is extrapolated from trends for data from 2000, 2005 and 2010 [1], and assumes a Cumulative Average Growth Rate (CAGR) of approximately 7%. The value obtained for 2016 is consistent with the prediction by the DatacenterDynamics (DCD) of 13.25 GW also for 2016. The extrapolation from 2016 to 2020 with the same CAGR yields 16.8 GW. The portion of the graph from 2020 to about 2023 assumes that network becomes a bigger percentage of energy utilization reaching as much as 50%, as predicted in [8], leading to an approximately 50% additional growth to 30 GW for 2023. After 2022, the effects of reaching the limits of metal interconnects for delivering the required throughput to the anticipated many-core chips is added. As an illustration of this last point, in [14] we observe that by 2022, assuming a constant IO B/FLOP, the metal interconnects fail to deliver the required I/O throughput to the future server chip – resulting in a further limitation of energy efficiency growth in datacenters. The shaded region indicates the uncertainty in predicting future demand.

Questions about this FOA? Check the Frequently Asked Questions available at <http://arpa-e.energy.gov/faq>. For questions that have not already been answered, email [ARPA-E-CO@hq.doe.gov](mailto:ARPA-E-CO@hq.doe.gov) (with FOA name and number in subject line); see FOA Sec. VII.A. Problems with ARPA-E eXCHANGE? Email [ExchangeHelp@hq.doe.gov](mailto:ExchangeHelp@hq.doe.gov) (with FOA name and number in subject line).

reporting cooling efficiencies approaching optimal values. Due, in part, to the existing strong level of investments in the infrastructure components, these elements are not considered under this FOA.

It is anticipated that future datacenter performance limits will stem from the inability of the datacenter network to keep pace with increased data loads to/from future server chip technology. Therefore, one opportunity for transformative improvement comes from enabling new network topologies and data management protocols through advanced integrated photonics systems. **ENLITENED** is targeting the efficiency of the IT elements of datacenters – and specifically the networking elements (interconnects and switching elements) of the datacenter.

A commonly-used measure of datacenter efficiency is PUE (Power Usage Effectiveness). PUE is defined as the ratio of total energy consumed by the datacenter ( $E_{total}$ ) to that consumed by the IT equipment ( $E_{IT}$ ). The total energy used by a datacenter can therefore be expressed as:

$$E_{total} = PUE \cdot E_{IT}$$

Often, the “PUE” factor lumps in all other factors such as cooling, power conditioning and delivery. Other smaller facilities-related consumption, such as lighting, is also added in certain estimations. Many companies report decreasing PUE values, yet this number does not reveal the amount of energy consumed. In most cases, the majority of the energy is consumed by IT equipment and the proportion is growing, due in part, to lower PUE achievements. It is also true that if IT energy consumption is reduced, this results in less energy consumed by cooling and power delivery in roughly the same proportion, because both are directly driven by IT energy use. It is this IT energy that is the target of the **ENLITENED** program.

A number of studies suggest that the IT network is an increasing fraction of the total IT power, in some case over 50% [12, 15, 18, 19]. Innovation in networking components and topologies can reduce the power consumed by the IT network, and further increase system efficiency in other ways, such as enabling a reduced percent of idle time of processor chips that consume significant energy while not being utilized [8,13] via higher overall network bandwidth and lower network latency. For example, for the datacenter schematic depicted in the bottom portion of Figure 2, higher bandwidth components could enable fewer switch nodes with higher port count per switch, in turn reducing the number of “hops” and idle time between servers, resulting in less energy consumed for the same transaction.

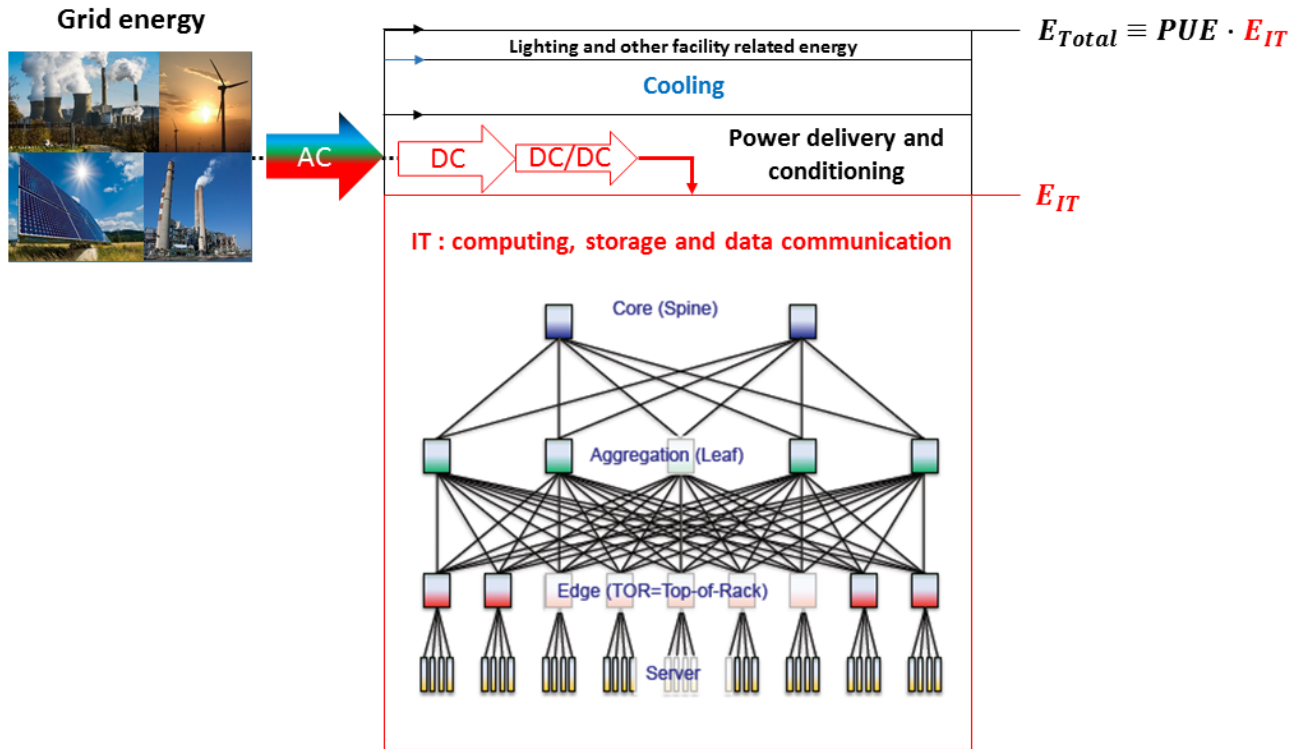

Figure 2. Schematic depiction of a datacenter and sources of energy consumption, the primary being IT, followed by cooling and power delivery and conditioning. The schematic at the bottom represents a datacenter network with servers as the bottom thin yellow boxes and switches as red, green and blue boxes.

The datacenter depicted in Figure 2 is one with a “Fat-Tree” network topology, with lines representing data interconnects between switches and servers – the lines and nodes in the diagram are “the network.” Typically, switches receive, store and forward data, and play a role in data routing decisions. Within each server are central processor and memory chips mounted on printed circuit boards that perform the majority of calculations and data storage. The first level of hierarchy for data communications outside of the server is called the “Top-of-Rack” (TOR) switch, which usually has the largest number of connections compared to all other network switches. Data communication at the level of the TOR and above is commonly referred to as “east-west” and from the TOR to the processor and memory chips within server boards as “north-south.” Although the “network” is often considered to be all data transactions outside of a server, in fact a large amount of data communication occurs “on-board”, right up to the edge of the memory and processor chips inside server boards. **ENLITENED** seeks to invest in technologies that can be integrated right up to the edge of the chip (i.e., integrated directly with the chip carrier) to enable both increased performance as well as transformative gains in energy efficiency.

Questions about this FOA? Check the Frequently Asked Questions available at <http://arpa-e.energy.gov/faq>. For questions that have not already been answered, email [ARPA-E-CO@hq.doe.gov](mailto:ARPA-E-CO@hq.doe.gov) (with FOA name and number in subject line); see FOA Sec. VII.A. Problems with ARPA-E eXCHANGE? Email [ExchangeHelp@hq.doe.gov](mailto:ExchangeHelp@hq.doe.gov) (with FOA name and number in subject line).



## Meeting Future Datacenter Needs: Overcoming the Bandwidth Bottleneck

There are two areas of concern that will limit future datacenter system performance. Chip-scale metal interconnects limit the scalability of silicon-chip-based electrical switches and therefore, are a fundamental source of future datacenter inefficiency [15]. Similarly, the metal interconnects connecting server chips and memory units to each other and the network interface will not be able to keep pace in an energy-efficient way with the bandwidth demands [14]. As bandwidth and capacity requirements of datacenters grow, the limitations of electrical interconnects will become further exaggerated when compared to integrated photonics technologies that are inherently more energy-efficient and capable of having far greater bandwidth-per-channel and bandwidth density at the chip scale [14]. There is an ever-increasing fraction of datacenter power requirements and costs dedicated to the intra-datacenter network, with projections suggesting further increases [12, 13].

Although integrated photonics technologies have been shown to achieve much lower link and switch energies than metal and electronic technologies, wide-spread deployment (such as in future datacenters) must overcome significant fabrication cost barriers to replace metal interconnects on server boards and to switching elements. Consequently, **ENLITENED** specifically targets the development of fabrication/manufacturing techniques that address the integration and packaging of photonic data-com technologies within server environments and the development of novel networking architectures that take advantage of these photonic technologies.

Figure 3 is a comparative schematic depiction of chip-scale integrated electronic and photonic interconnects which highlights the key issues for metallic interconnects and the key challenges that must be overcome in next-generation integrated photonics technologies. State-of-the-art server or switch chips (depicted as orange squares) are mounted on chip-carriers (depicted as blue squares with black dots indicating metal connection points to the underlying board) that provide the metal trace interface to the underlying circuit board. Two key attributes determine the I/O capability of the system: the “escape bandwidth density” for the chip package and the energy-per-bit (E/b) consumed for each link. The escape bandwidth density is defined as the linear bandwidth density around the periphery of the chip or chip package and is limited by the geometric and physical constraints of the chip-carrier on pin density, number of wiring layers, cross-talk, line termination requirements, etc. Traditional multi-layer chip-carrier techniques approaches are limited to approximately 1 Tb/s/cm in escape bandwidth density [20]. Furthermore, due to the fundamental loss mechanisms in high-bandwidth electrical transport, energy requirements for high-density integrated metallic links are approximately proportional to the length of the link. State-of-the-art metal links can achieve approximately 0.5 pJ/b/cm and therefore the length of required inter-chip links is a critical concern. As server and switch chip technology continues to scale, the ability of metal interconnects to keep pace is projected to be limited [14].

In contrast to integrated metallic interconnects, integrated photonic interconnects offer the potential to provide much higher escape bandwidth and E/b performance that is essentially

independent of the chip-scale interconnect distance, as depicted in the lower half of Figure 3. At the inter-chip distances considered here, waveguide and fiber transport is essentially lossless. E/b performance for optical links have been demonstrated at approximately 1 pJ/b [14] and projected performance for integrated photonic links may achieve even much lower levels of E/b [14]. What's more, due to the ability of waveguides to carry highly multiplexed signals, and be packed in high density with little crosstalk, the potential escape bandwidth of integrated photonic interconnects far exceeds that of metal interconnects.

As depicted in Figure 3, the critical implementation challenge for integrated photonic links is the transduction from the electronic to optical domains (E→O) at the transmitter and the inverse (O→E) at the receiver. Integrated photonic technologies may achieve this through direct modulation of a laser diode (LD) and then detection of the photonic signal with a photodiode (PD) at the receiving end, as depicted, or other types of photonic modulation and detection of laser signals may be employed. In any integrated photonic scheme, the electronic/photonic transductions present the critical integration and packaging challenges for efficiently interfacing to the server or switch chip and the waveguide structure that comprises to actual interconnect fabric.

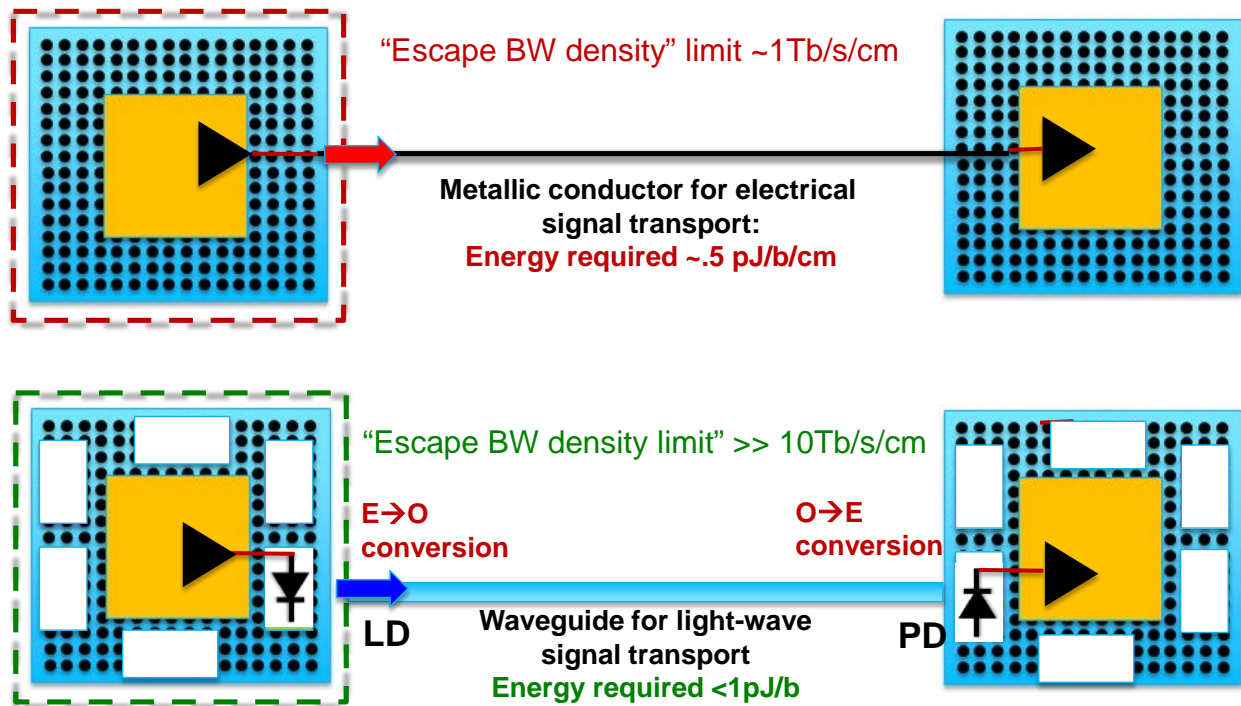

Figure 3. Schematic demonstrating an “interconnect” between processor chips and limitations using electrical metal links (above) and optical waveguide (below) interconnection technologies. Due to practical and dimensional design limitations of about ~200 W/processor chip and other physical constraints of metal wires [14], data transfer rates into and out of processor chips are limited and distances over which electrical signals can travel are limited due to signal loss (~0.5

pJ/b/cm). Optical interconnects are virtually lossless as a function of distance and enable a much greater “escape bandwidth” to increase the chip input/output data rates, however, E/O and O/E (O= optical, E = electrical) conversion steps must be efficient to minimize heating and achieve higher overall efficiency.

### C. PROGRAM OBJECTIVES

The overall objective of the **ENLITENED** Program is to create new technology platforms, components, and evaluation methods to enable a > 2-fold improvement in the energy efficiency of datacenter ICT infrastructure.

Although the energy needs and functions of datacenters vary, ARPA-E posits that efficiency can be improved across all datacenter applications via the incorporation of advanced integrated chip-scale photonic interconnects and switching technologies. Although no one universal metric for datacenter efficiency may be applied to all cases, ARPA-E considers a doubling of the average “Transactions/Joule” (interpreted as a “wall-plug” efficiency for the entire ICT system of the datacenter) to be a plausible general target. One objective of **ENLITENED** is to tie different use-cases and data loads to a standard system-level metric: “Transactions” in the numerator and energy consumed by the entire datacenter ( $E_{IT}$  in Figure 2) during those transactions in the denominator. This would enable greater clarity for innovation to optimize for energy at the system level and evaluate other performance trade-offs. Examples of intermediate system-level metrics from which “Transaction” units can be derived could be measures such as FLOPS/Joule and bytes/FLOP for a series of queries, the number of intermediate switch hops and overall time for a given byte or data packet to travel between servers, and so forth. Such analysis will enable objective measures of datacenter energy-efficiency and easier comparison across computational models and hardware sub-systems.

ARPA-E anticipates that this level of datacenter system efficiency improvement will stem in part from the fundamentally lower energy-per-bit achievable with integrated photonic links. The remaining significant efficiency improvements will stem from changes in network architecture enabled by the ultra-high bandwidth density of photonics and low latency photonic switch fabrics. The closer integration of switching and computational elements that will emerge from **ENLITENED** will potentially blur the distinctions now made in techno-economic analyses of server, switch, and transceiver costs for datacenters. Nevertheless, ARPA-E estimates that an effective cost structure is needed to bring **ENLITENED** technologies to market by putting packaged technologies on a path to < 10 cents/Gb/s for integrated transceivers and aggregate switch bandwidths > 50 Tb/s, capable of radix > 128 [18]. Early market insertion opportunities may be possible in other areas such as high-performance computing (HPC), where performance and energy efficiency are prioritized over market cost metrics.

At the end of the program, ARPA-E expects datacenter sub-systems and architectures, supported by detailed modeling and simulation that achieve a 2-fold or greater average improvement in energy efficiency as well as a path to commercialization.

Questions about this FOA? Check the Frequently Asked Questions available at <http://arpa-e.energy.gov/faq>. For questions that have not already been answered, email [ARPA-E-CO@hq.doe.gov](mailto:ARPA-E-CO@hq.doe.gov) (with FOA name and number in subject line); see FOA Sec. VII.A. Problems with ARPA-E eXCHANGE? Email [ExchangeHelp@hq.doe.gov](mailto:ExchangeHelp@hq.doe.gov) (with FOA name and number in subject line).

#### D. **PROGRAM STRUCTURE AND TECHNICAL CATEGORIES OF INTEREST**

ARPA-E anticipates a 2-phase, 4-year program for **ENLITENED**, however *the initial period of performance for awards resulting from this FOA will be for Phase 1 and will not exceed two years. Phase 2, also a maximum of 2 years, may only be awarded contingent upon successful completion of Phase 1 and will be subject to the availability of appropriated funds. All Applicants must provide budgets and task descriptions that cover both Phase 1 and Phase 2 (a maximum of 4 years total).* Details are described below. The program objective is a packaged hardware solution consistent with a computational datacenter model and/or calculations that demonstrate the potential to achieve an average 2-fold improvement in energy efficiency for a broad range of use cases.

Applicants are encouraged to have vertically-integrated teams that bring together technology, packaging and integration, and network architecture expertise. ARPA-E may also consider **partial solutions**, for example, of a **component that has a critical path to being packaged and integrated into datacenter sub-systems, a new integration and packaging approach that could have broad impact, or a computational modeling approach** that can be used, together with realistic hardware specifications and datacenter constraints, to design solutions that meet the program metrics.

##### **Full Solutions**

Vertically-integrated teams are expected to develop the integration and packaging concepts needed to enable chip-scale ultra-high-density photonic link and switching technologies within future datacenters. It is anticipated that, depending on the integrated photonic technologies proposed, potential solutions will have differing levels of hybridization/integration between electronic and photonic elements. Applicants must propose, and articulate a rationale for, an integrated technology platform (that includes links, transceivers, switching elements, control strategies, and all interfacing technologies and techniques) needed to couple the photonic elements to the anticipated electronic computing elements at the chip, chip package, board and intra-rack-levels, as appropriate in future datacenters. Applicants must present a network structure enabled by the integrated technologies that would lead to transformative energy-efficiency improvements.

Implementation of Phase 2 for the **ENLITENED** program will depend on satisfactory progress across the program during Phase 1, subject to the availability of appropriated funds and other factors. Project teams will be expected to deliver analyses, perform sub-system experiments (as detailed below), and refine a Phase 2 project plan that will enable ARPA-E to make informed selections for the second phase. If ARPA-E selects a project to continue to Phase 2, the team will develop more significant experimental validations of their concept that culminates with critical analyses, simulation, and hardware-in-the-loop experiments that will enable valid assessment of the technologies and progress towards commercialization.

Questions about this FOA? Check the Frequently Asked Questions available at <http://arpa-e.energy.gov/faq>. For questions that have not already been answered, email [ARPA-E-CO@hq.doe.gov](mailto:ARPA-E-CO@hq.doe.gov) (with FOA name and number in subject line); see FOA Sec. VII.A. Problems with ARPA-E eXCHANGE? Email [ExchangeHelp@hq.doe.gov](mailto:ExchangeHelp@hq.doe.gov) (with FOA name and number in subject line).

An expectation of Phase 2 success is demonstration of the concept at a minimal system level. For example, a new transceiver or switch architecture must take into account all system elements that consume energy such as clock and data recovery, re-timing circuitry, and other system level inefficiencies. Applicants pursuing full solutions should propose goals that are ambitious and exceed the current goals of other commercial efforts in terms of energy efficiency, such as those of the Consortium of On-Board Optics (COBO) [11].

### **Partial Solutions**

ARPA-E anticipates that some teams may not be fully “vertically integrated” or “full solution” as described above, but may provide a valuable partial solution that could contribute significantly to achieving the program objectives. Such projects may have a hardware solution that is significantly less than a full system, for example a laser or modulator array that is to be packaged into a transceiver or switch. Others may have novel datacenter network architectural notions that promise to take full advantage of emerging photonics technologies in future datacenters using realistic components and show a clear commercial path to achieving the program metrics, yet not currently be part of a team that has the matching hardware solutions.

ARPA-E anticipates that partial solutions may be more suited to Phase 1, but a Phase 2 path must at least be addressed, albeit in less detail than vertically integrated teams. As listed in Section IV.C “Content and Form of Concept Papers,” and in the Concept Paper template document, teams pursuing partial solutions are expected to submit Concept Papers of no more than 4 pages in length. For certain common components that have well-demonstrated performance, for example, high efficiency/bandwidth lasers, modulators, couplers, etc.; a two-year window may be critical for integration and packaging into existing product lines.

For teams pursuing partial solutions to design and simulate novel network architectures only, **Submissions Concept Papers** must explain how their proposed network design will leverage projected performance advantages of photonics-enabled sub-systems. Teams must use realistic [10] component technology specifications and techno-economic analyses and address all technical performance targets, even though they may not have experimental measurements as part of their Phase 1 project plan.

## **E. TECHNICAL PERFORMANCE TARGETS AND DELIVERABLES**

The **ENLITENED** technical performance targets are designed to demonstrate the ability of any proposed solution to meet the transformative energy efficiency objective described in this FOA when compared to *anticipated* state-of-the-art electrical interconnect and networking technologies. In other words, the benefits of the proposed solution must be in addition to any future improvements in CPU, memory, or other datacenter electrical components or

architectural efficiency enhancements (e.g., anticipated silicon CMOS scaling, or energy-proportional computing strategies).<sup>4</sup>

Applicants must address the overall 2x average system efficiency improvement target in the context of datacenters at all scales (large, small, multi-tenant etc.), and diverse distributions of data loads. The justification of the efficiency improvement should include, in addition to datacenter diversity and data loads, the effects of format conversion between single-mode and multi-mode for North-South and East-West communications, number of E-O-E (or O-E-O) conversions, etc., if appropriate. Table 1 provides targets for Program Metrics. **The target in Metric 1.1 is the overall program objective and must be addressed in all submissions. If an Applicant proposes a concept to meet the target in Metric 1.1 without meeting the targets in Metrics 1.2-1.5, the Applicant must provide alternative targets for Metrics 1.2-1.5 and still provide a rationale showing how the target in Metric 1.1 will nevertheless be met.**

Comprehensive simulation results are not expected in concept papers, but a quantifiable argument for how the 2x efficiency improvement (excluding cooling and power down conversion effects) will be reached must be presented. Metric 1.6 refers to the technology economic assessment. **For Full Applications, a more comprehensive justification for achieving Metric 1.1 is expected. Applicants should provide a detailed energy and bandwidth budget table(s) in the Technical Volume that include all energies for each subsystem required to evaluate the transaction per Joule figure of merit.** Example computational parameters and types of analyses that may be appropriate to include as part of energy budget and impact projection calculations detailed in Full Applications include:

- Definition of a transaction or types of transactions(e.g., search, image analysis);
- Size of, and/or range of sizes and size distributions of, transactions – in, e.g., bytes or other appropriate measures;
- Number of operations per transaction and transaction time;
- Energy consumed during a transaction (referenced to “wall plug” energy, with assumptions provided);
- A simulation and/or modeling analysis, based on the above parameters, or other appropriate measures, that compares transaction processing performance in current data center networking architectures with the proposed future datacenter network architecture enabled by the proposed integrated photonic platform, with reasonable assumptions about other future datacenter components, such as Moore’s law-type CPU scaling. This analysis could specify and include, as appropriate, key datacenter network properties, such as: topology and number of nodes; number of servers; types of CPU chips in servers; memory; number of switches and their aggregate bandwidth and port-count (radix); description of photonic links and their length and bandwidth; description of any required copper links and their lengths and bandwidths; total hops per bit and latency across the datacenter; etc.

---

<sup>4</sup> For example the system efficiency improvement could be shown by exhibiting simulations with and without the photonic technologies but both including other future improvements

- Comparative analyses that estimate/project the performance enhancements provided by integrated photonics across a range of important data center service types and data center sizes.
- Comparative analyses that estimate/project energy consumption as a function of work load – to highlight, e.g., the energy-consumption benefits of the proposed architecture under quiescent and reduced traffic conditions.
- Comparative analyses, that, to the extent possible, project impact at a national level, under the assumption of wide-scale deployment of the proposed technology

In general, any provided energy and bandwidth budget tables should inform and illustrate how Metric 1.1 could be met with the proposed concept, and how well the projections can be generalized to other datacenter types to understand the breadth of the impact. There may be components of full solution concepts that are required for operation, but are not specifically addressed such as energy required for clock and data recovery (CDR), or memory refresh. Although the task descriptions may not address elements such as these explicitly, the energy budget estimates should take into account how the overall datacenter architecture will be affected by other critical elements, or how these may be bypassed.

Applicants should identify the specific datacenter structures targeted for innovation. Examples of this would be creating a switch architecture that combines many top of rack and core switches into one and meeting the FOA metrics by reducing the number of “hops” for the majority of data packets, while increasing bandwidth and processor utilization. This example may include both “short” and “long reach” hardware elements that could be addressed by both VCSELs over multi-mode fiber as well as Silicon photonics, for example. Another example would be targeting the infrastructure “below the Top of Rack”, which would likely be dealing with mostly “short reach” communications that take place between CPUs and memory elements inside the “server unit” of current datacenter designs. Of interest are approaches that aim to disaggregate datacenter elements and blur boundaries between servers, as such architectures are predicted to have advantages in performance and energy efficiency and potentially maintenance and reliability.

Table 1: Program Metrics

ID	Metric	Target	Description
1.1	System Energy Efficiency	>2x “Transactions /Joule”	• Applicants must show how their proposed integrated photonics and new switch network provides a credible path to >2x efficiency.
1.2	Link Demo	< 2 pJ/bit	• Must show a path to <1 pJ/bit for inter-chip board-level links of length 1 to 100 cm.
1.3	BW Density Demo: Chip or Chip carrier I/O	> 1Tb/s/cm	• The proposed packaging approach should enables aggregate bandwidths of 10 Tb/s or greater for future server or switch chips.

Questions about this FOA? Check the Frequently Asked Questions available at <http://arpa-e.energy.gov/faq>. For questions that have not already been answered, email [ARPA-E-CO@hq.doe.gov](mailto:ARPA-E-CO@hq.doe.gov) (with FOA name and number in subject line); see FOA Sec. VII.A. Problems with ARPA-E eXCHANGE? Email [ExchangeHelp@hq.doe.gov](mailto:ExchangeHelp@hq.doe.gov) (with FOA name and number in subject line).

1.4	Board Level I/O	Applicant-provided	<ul style="list-style-type: none"> <li>Board-level I/O will be determined by specifics of proposed network architecture.</li> </ul>
1.5	Switch Concept	Applicant-provided	<ul style="list-style-type: none"> <li>Must show how integrated photonics enables an efficient architecture ( &gt; 2x efficiency from item 1)</li> <li>Specify required switch metrics (e.g., radix &gt; 128, end-to-end Energy/bit, etc.)</li> <li>Define how store and forward steps, latency affect overall system performance and energy</li> <li>Switch concepts must show path to &gt; 50 Tb/s aggregate bandwidth per switch</li> </ul>
1.6	Technology Economic Assessment	Applicant-provided	<ul style="list-style-type: none"> <li>Show cost effective packaging compatible with server/communication equipment</li> <li>IP enables path to &lt; \$0.10/Gb/s at inter board level</li> <li>Network cost: Applicants must provide TEA to eventual wide scale deployment of the proposed IP –architecture</li> </ul>

**Deliverables**

“Full solutions” applicants must experimentally validate the listed program metrics in Table 1. These deliverables must make a convincing case for commercial transition. Applicants must provide a technical approach and milestone plan for achieving the deliverables. Full solution Applicants must propose the following five deliverables for Phase 1:

1. Laboratory demonstration of a chip-level integrated photonic link with a clear path to < 1 pJ/b for 1-100 cm link lengths and an integrated interconnect demonstration that shows a path to 10 Tb/s for future server and switch chips.
2. Laboratory demonstration of an integrated switching concept that exploits the proposed photonic link concept and enables the proposed networking architecture.
3. Network architecture and datacenter simulations that are consistent with the experimentally-measured results from 1 and 2 and show a path to at least a 2-fold improvement in average energy efficiency.
4. A technical plan for the packaging and integration of all system components considered and methods of manufacturing identified with accompanying techno-economic analysis.
5. Submission, at the end of Phase 1, of an **updated**, detailed Phase 2 plan that builds upon the Phase I deliverables and refined simulations and proposes prototype integrated packaged sub-systems with sufficient numbers of links and switching elements to validate the proposed concept.

Questions about this FOA? Check the Frequently Asked Questions available at <http://arpa-e.energy.gov/faq>. For questions that have not already been answered, email [ARPA-E-CO@hq.doe.gov](mailto:ARPA-E-CO@hq.doe.gov) (with FOA name and number in subject line); see FOA Sec. VII.A. Problems with ARPA-E eXCHANGE? Email [ExchangeHelp@hq.doe.gov](mailto:ExchangeHelp@hq.doe.gov) (with FOA name and number in subject line).



“Partial solutions” applicants must specify their own quantifiable milestones and deliverables as appropriate, but consistent with showing well-defined paths to the overall program objective via detailed simulations.

### **Additional Clarifications for Partial Solutions**

Applicants developing partial hardware solutions must address all of the above metrics during the **ENLITENED** program, even though the metrics may not be directly measured as part of proposed project plans. Applicants must provide intermediate metrics and relate those to system level performance. For example, if a partial solution that involves the packaging and integration of a laser array into an existing product line were proposed, other metrics would be expected such as modulation rate, total wall-plug power per port, coupling efficiency, error-free bit-rate per port, inside of a prototype packaged system.

Similarly, for partial solutions consisting of modeling and simulation (not experimental work) , teams must demonstrate the ability to communicate and understand what industry customers require, as well as the inner workings of both enterprise scale and hyper-scale cloud datacenters. Teams must be technically competent to perform state-of-the-art simulations to evaluate experimental results from hardware developers and simulate datacenter operation by varying the size of the datacenter (number of servers and switches), the topology of the datacenter (Clos-type, HyperX, All-to-All, Fat-Tree, etc.) and software-defined datacenter algorithms.

### **Additional Clarifications for Computational Modeling**

All **Submissions** **Concept Papers** that include network architecture/system modeling, whether vertically integrated teams, or partial solutions (without experiments), must:

- Develop models that show innovative ways to reach a global energy efficiency improvement  $> 2 \times$  Transactions/Joule. This universal metric must be related across datacenter sizes, with different data load size distributions, activity patterns and computational metrics. Other measures such as FLOPS/Watt, FLOPS/Joule, bytes/FLOP must be related to expected global gains.
- Specify topologies and compare to the state-of-the-art.
- Specify data loads, where the data will be obtained and how relevant these data sets and traffic patterns are to evolving datacenter trends.
- Have models that use realistic system components, including the most advanced and anticipated integrated photonics capabilities being developed by other teams in the **ENLITENED** program and enable modularity to evaluate how the global metric is affected by changes in components and topologies. Physics-based constraints must be taken into account as well, such as the trade-offs in bandwidth density per area, heat generated per area, etc.
- Provide a techno-economic justification for the computational model to evaluate the feasibility of adoption. This must take into account realistic models of CAPEX and OPEX

Questions about this FOA? Check the Frequently Asked Questions available at <http://arpa-e.energy.gov/faq>. For questions that have not already been answered, email [ARPA-E-CO@hq.doe.gov](mailto:ARPA-E-CO@hq.doe.gov) (with FOA name and number in subject line); see FOA Sec. VII.A. Problems with ARPA-E eXCHANGE? Email [ExchangeHelp@hq.doe.gov](mailto:ExchangeHelp@hq.doe.gov) (with FOA name and number in subject line).

and creative ways of how new datacenters could be manufactured or retrofit with emerging technologies in a cost effective way. Thought leadership for creative ways that industry can adapt to limitations of power, real-estate and other constraints are welcome.

## II. AWARD INFORMATION

### A. AWARD OVERVIEW

ARPA-E expects to make approximately \$25 million available for **new Phase 1 (as described below)** awards under this FOA, subject to the availability of appropriated funds. ARPA-E anticipates making **approximately 12-15 8-15** awards under this FOA. ARPA-E may, at its discretion, issue one, multiple, or no awards.

Individual awards **for both Phase 1 and Phase 2 (if a Phase 1 project is chosen to progress to Phase 2) combined** may vary between \$250,000 and \$10 million.

~~The period of performance for funding agreements may not exceed 24 months.~~ ARPA-E anticipates a 2-phase, 4-year program for **ENLITENED**, however the **initial** period of performance for awards resulting from this FOA will be for Phase I **only** and will not exceed 24 months. Phase 2, also a maximum of 2 years, may **only** be awarded **to selected projects** contingent upon successful completion of Phase 1 and will be subject to the availability of appropriated funds. ARPA-E expects the start date for funding agreements to be June 2017, or as negotiated.

ARPA-E encourages submissions stemming from ideas that still require proof-of-concept R&D efforts as well as those for which some proof-of-concept demonstration already exists.

Submissions requiring proof-of-concept R&D can propose a project with the goal of delivering on the program metric at the conclusion of the period of performance. These submissions must contain an appropriate cost and project duration plan that is described in sufficient technical detail to allow reviewers to meaningfully evaluate the proposed project. If awarded, such projects should expect a rigorous go/no-go milestone early in the project associated with the proof-of-concept demonstration. Alternatively, submissions requiring proof-of-concept R&D can propose a project with the project end deliverable being an extremely creative, but partial solution. However, the Applicants are required to provide a convincing vision how these partial solutions can enable the realization of the program metrics with further development.

Applicants proposing projects for which some initial proof-of-concept demonstration already exists should submit concrete data that supports the probability of success of the proposed project.

ARPA-E will provide support at the highest funding level only for submissions with significant technology risk, aggressive timetables, and careful management and mitigation of the associated risks.

ARPA-E will accept only new submissions under this FOA. Applicants may not seek renewal or supplementation of their existing awards through this FOA.

ARPA-E plans to fully fund your negotiated Phase 1 budget at the time of award.

## **B. ARPA-E FUNDING AGREEMENTS**

Through Cooperative Agreements, Technology Investment Agreements, and similar agreements, ARPA-E provides financial and other support to projects that have the potential to realize ARPA-E's statutory mission. ARPA-E does not use such agreements to acquire property or services for the direct benefit or use of the U.S. Government.

Congress directed ARPA-E to "establish and monitor project milestones, initiate research projects quickly, and just as quickly terminate or restructure projects if such milestones are not achieved."<sup>5</sup> Accordingly, ARPA-E has substantial involvement in the direction of every Cooperative Agreement, as described in Section II.C below.

### **1. COOPERATIVE AGREEMENTS**

ARPA-E generally uses Cooperative Agreements to provide financial and other support to Prime Recipients.<sup>6</sup>

Cooperative Agreements involve the provision of financial or other support to accomplish a public purpose of support or stimulation authorized by Federal statute. Under Cooperative Agreements, the Government and Prime Recipients share responsibility for the direction of projects.

ARPA-E encourages Prime Recipients to review the Model Cooperative Agreement, which is available at <http://arpa-e.energy.gov/arpa-e-site-page/award-guidance>.

### **2. FUNDING AGREEMENTS WITH FFRDCs/DOE LABS, GOGOs, AND FEDERAL INSTRUMENTALITIES**

Any Federally Funded Research and Development Centers (FFRDC) involved as a member of a Project Team must provide the information requested in the "FFRDC Lab Authorization" and

---

<sup>5</sup> U.S. Congress, Conference Report to accompany the 21<sup>st</sup> Century Competitiveness Act of 2007, H. Rpt. 110-289 at 171-172 (Aug. 1, 2007).

<sup>6</sup> The Prime Recipient is the signatory to the funding agreement with ARPA-E.

“Field Work Proposal” section of the Business Assurances & Disclosures Form, which is submitted with the Applicant’s Full Application.

When a FFRDC/DOE Lab (including the National Energy Technology Laboratory or NETL) is the *lead organization* for a Project Team, ARPA-E executes a funding agreement directly with the FFRDC/DOE Lab and a single, separate Cooperative Agreement with the rest of the Project Team. Notwithstanding the use of multiple agreements, the FFRDC/DOE Lab is the lead organization for the entire project, including all work performed by the FFRDC/DOE Lab and the rest of the Project Team.

When a FFRDC/DOE Lab is a *member* of a Project Team, ARPA-E executes a funding agreement directly with the FFRDC/DOE Lab and a single, separate Cooperative Agreement with the rest of the Project Team. Notwithstanding the use of multiple agreements, the Prime Recipient under the Cooperative Agreement is the lead organization for the entire project, including all work performed by the FFRDC/DOE Lab and the rest of the Project Team.

Funding agreements with DOE/NNSA FFRDCs take the form of Work Authorizations issued to DOE/NNSA FFRDCs through the DOE/NNSA Field Work Proposal system for work performed under Department of Energy Management & Operation Contracts. Funding agreements with non-DOE/NNSA FFRDCs, GOGOs (including NETL), and Federal instrumentalities (e.g., Tennessee Valley Authority) will be consistent with the sponsoring agreement between the U.S. Government and the Laboratory. Any funding agreement with a FFRDC or GOGO will have similar terms and conditions as ARPA-E’s Model Cooperative Agreement (<http://arpa-e.energy.gov/arpa-e-site-page/award-guidance>).

Non-DOE GOGOs and Federal agencies may be proposed to provide support to the project team members on an applicant’s project, through a Cooperative Research and Development Agreement (CRADA) or similar agreement.

### **3. TECHNOLOGY INVESTMENT AGREEMENTS**

ARPA-E may use its “other transactions” authority under the America COMPETES Reauthorization Act of 2010 or DOE’s “other transactions” authority under the Energy Policy Act of 2005 to enter into Technology Investment Agreements (TIAs) with Prime Recipients. ARPA-E may negotiate a TIA when it determines that the use of a standard cooperative agreement, grant, or contract is not feasible or appropriate for a project.

A TIA is more flexible than a traditional financial assistance agreement. In using a TIA, ARPA-E may modify standard Government terms and conditions. See 10 C.F.R. § 603.105 for a description of a TIA.

In general, TIAs require a cost share of 50%. See Section III.B.2 of the FOA.

Questions about this FOA? Check the Frequently Asked Questions available at <http://arpa-e.energy.gov/faq>. For questions that have not already been answered, email [ARPA-E-CO@hq.doe.gov](mailto:ARPA-E-CO@hq.doe.gov) (with FOA name and number in subject line); see FOA Sec. VII.A. Problems with ARPA-E eXCHANGE? Email [ExchangeHelp@hq.doe.gov](mailto:ExchangeHelp@hq.doe.gov) (with FOA name and number in subject line).

### **C. STATEMENT OF SUBSTANTIAL INVOLVEMENT**

ARPA-E is substantially involved in the direction of projects from inception to completion. For the purposes of an ARPA-E project, substantial involvement means:

- Project Teams must adhere to ARPA-E’s agency-specific and programmatic requirements.
- ARPA-E may intervene at any time in the conduct or performance of work under an award.
- ARPA-E does not limit its involvement to the administrative requirements of an award. Instead, ARPA-E has substantial involvement in the direction and redirection of the technical aspects of the project as a whole.
- During award negotiations, ARPA-E Program Directors and Prime Recipients mutually establish an aggressive schedule of quantitative milestones and deliverables that must be met every quarter. In addition, ARPA-E will negotiate and establish “Go/No-Go” milestones for each project. If the Prime Recipient fails to achieve any of the “Go/No-Go” milestones or technical milestones and deliverables as determined by the ARPA-E Contracting Officer, ARPA-E may – at its discretion - renegotiate the statement of project objectives or schedule of technical milestones and deliverables for the project. In the alternative, ARPA-E may suspend or terminate the award in accordance with 2 C.F.R. §§ 200.338 and 200.339.
- ARPA-E may provide guidance and/or assistance to the Prime Recipient to accelerate the commercial deployment of ARPA-E-funded technologies. Guidance and assistance provided by ARPA-E may include coordination with other Government agencies and nonprofits to provide mentoring and networking opportunities for Prime Recipients. ARPA-E may also organize and sponsor events to educate Prime Recipients about key barriers to the deployment of their ARPA-E-funded technologies. In addition, ARPA-E may establish collaborations with private and public entities to provide continued support for the development and deployment of ARPA-E-funded technologies.

Questions about this FOA? Check the Frequently Asked Questions available at <http://arpa-e.energy.gov/faq>. For questions that have not already been answered, email [ARPA-E-CO@hq.doe.gov](mailto:ARPA-E-CO@hq.doe.gov) (with FOA name and number in subject line); see FOA Sec. VII.A. Problems with ARPA-E eXCHANGE? Email [ExchangeHelp@hq.doe.gov](mailto:ExchangeHelp@hq.doe.gov) (with FOA name and number in subject line).

### **III. ELIGIBILITY INFORMATION**

#### **A. ELIGIBLE APPLICANTS**

##### **1. INDIVIDUALS**

U.S. citizens or permanent residents may apply for funding in their individual capacity as a Standalone Applicant,<sup>7</sup> as the lead for a Project Team,<sup>8</sup> or as a member of a Project Team. However, ARPA-E will only award funding to an entity formed by the Applicant.

##### **2. DOMESTIC ENTITIES**

For-profit entities, educational institutions, and nonprofits<sup>9</sup> that are incorporated in the United States, including U.S. territories, are eligible to apply for funding as a Standalone Applicant, as the lead organization for a Project Team, or as a member of a Project Team.

FFRDCs/DOE Labs are eligible to apply for funding as the lead organization for a Project Team or as a member of a Project Team that includes institutions of higher education, companies, research foundations, or trade and industry research collaborations, but not as a Standalone Applicant.

State, local, and tribal government entities are eligible to apply for funding as a member of a Project Team, but not as a Standalone Applicant or as the lead organization for a Project Team.

Federal agencies and instrumentalities (other than DOE) are eligible to apply for funding as a member of a Project Team, but not as a Standalone Applicant or as the lead organization for a Project Team.

##### **3. FOREIGN ENTITIES**

Foreign entities, whether for-profit or otherwise, are eligible to apply for funding as Standalone Applicants, as the lead organization for a Project Team, or as a member of a Project Team. Foreign entities must designate in the Full Application a subsidiary or affiliate incorporated (or otherwise formed or to be formed) under the laws of a State or territory of the United States to

---

<sup>7</sup> A Standalone Applicant is an Applicant that applies for funding on its own, not as part of a Project Team.

<sup>8</sup> The term "Project Team" is used to mean any entity with multiple players working collaboratively and could encompass anything from an existing organization to an ad hoc teaming arrangement. A Project Team consists of the Prime Recipient, Subrecipients, and others performing or otherwise supporting work under an ARPA-E funding agreement.

<sup>9</sup> Nonprofit organizations described in section 501(c)(4) of the Internal Revenue Code of 1986 that engaged in lobbying activities after December 31, 1995 are not eligible to apply for funding as a Prime Recipient or Subrecipient.

receive funding. The Full Application must state the nature of the corporate relationship between the foreign entity and domestic subsidiary or affiliate. The Applicant may request a waiver of this requirement in the Business Assurances & Disclosures Form, which is submitted with the Full Application and can be found at <https://arpa-e-foa.energy.gov/>. Please refer to the Business Assurances & Disclosures Form for guidance on the content and form of the request.

#### **4. CONSORTIUM ENTITIES**

Consortia, which may include domestic and foreign entities, must designate one member of the consortium as the consortium representative to the Project Team. The consortium representative must be incorporated in the United States. The eligibility of the consortium will be determined by reference to the eligibility of the consortium representative under Section III.A of the FOA. Each consortium must have an internal governance structure and a written set of internal rules. Upon request, the consortium entity must provide a written description of its internal governance structure and its internal rules to the Contracting Officer ([ARPA-E-CO@hq.doe.gov](mailto:ARPA-E-CO@hq.doe.gov)).

Unincorporated consortia must provide the Contracting Officer with a collaboration agreement, commonly referred to as the articles of collaboration, which sets out the rights and responsibilities of each consortium member. This collaboration agreement binds the individual consortium members together and shall include the consortium's:

- Management structure;
- Method of making payments to consortium members;
- Means of ensuring and overseeing members' efforts on the project;
- Provisions for members' cost sharing contributions; and
- Provisions for ownership and rights in intellectual property developed previously or under the agreement.

#### **B. COST SHARING<sup>10</sup>**

Applicants are bound by the cost share proposed in their Full Applications.

---

<sup>10</sup> Please refer to Section VI.B.3-4 of the FOA for guidance on cost share payments and reporting.

## 1. BASE COST SHARE REQUIREMENT

ARPA-E generally uses Cooperative Agreements to provide financial and other support to Prime Recipients (see Section II.B.1 of the FOA). Under a Cooperative Agreement or Grant, the Prime Recipient must provide at least 20% of the Total Project Cost<sup>11</sup> as cost share, except as provided in Sections III.B.2 or III.B.3 below.<sup>12</sup>

## 2. INCREASED COST SHARE REQUIREMENT

Large businesses are strongly encouraged to provide more than 20% of the Total Project Cost as cost share. ARPA-E may consider the amount of cost share proposed when selecting applications for award negotiations (see Section V.B.1 of the FOA).

Under a Technology Investment Agreement, the Prime Recipient must provide at least 50% of the Total Project Cost as cost share. ARPA-E may reduce this minimum cost share requirement, as appropriate.

## 3. REDUCED COST SHARE REQUIREMENT

ARPA-E has reduced the minimum cost share requirement for the following types of projects:

- A domestic educational institution or domestic nonprofit applying as a Standalone Applicant is required to provide at least 5% of the Total Project Cost as cost share.
- Small businesses – or consortia of small businesses - will provide 0% cost share from the outset of the project through the first 12 months of the project (hereinafter the “Cost Share Grace Period”).<sup>13</sup> If the project is continued beyond the Cost Share Grace Period, then at least 10% of the Total Project Cost (including the costs incurred during the Cost Share Grace Period) will be required as cost share over the remaining period of performance.
- Project Teams where a small business is the lead organization and small businesses perform greater than or equal to 80%, but less than 100%, of the total work under

---

<sup>11</sup> The Total Project Cost is the sum of the Prime Recipient share and the Federal Government share of total allowable costs. The Federal Government share generally includes costs incurred by GOGOs and FFRDCs.

<sup>12</sup> Energy Policy Act of 2005, Pub.L. 109-58, sec. 988.

<sup>13</sup> Small businesses are generally defined as domestically incorporated entities that meet the criteria established by the U.S. Small Business Administration’s (SBA) “Table of Small Business Size Standards Matched to North American Industry Classification System Codes” (NAICS) (<http://www.sba.gov/content/small-business-size-standards>). Applicants that are small businesses will be required to certify in the Business Assurances & Disclosures Form that their organization meets the SBA’s definition of a small business under at least one NAICS code.



the funding agreement (as measured by the Total Project Cost) the Project Team are entitled to the same cost share reduction and Cost Share Grace Period as provided above to Standalone small businesses or consortia of small businesses.<sup>14</sup>

- Project Teams composed exclusively of domestic educational institutions, domestic nonprofits, and/or FFRDCs are required to provide at least 5% of the Total Project Cost as cost share.
- Project Teams where domestic educational institutions, domestic nonprofits, small businesses, and/or FFRDCs perform greater than or equal to 80%, of the total work under the funding agreement (as measured by the Total Project Cost) are required to provide at least 10% of the Total Project Cost as cost share. However, any entity (such as a large business) receiving patent rights under a class waiver, or other patent waiver, that is part of a Project Team receiving this reduction must continue to meet the statutory minimum cost share requirement (20%) for its portion of the Total Project Cost.
- Projects that do not meet any of the above criteria are subject to the minimum cost share requirements described in Sections III.B.1 and III.B.2 of the FOA.

#### **4. LEGAL RESPONSIBILITY**

Although the cost share requirement applies to the Project Team as a whole, the funding agreement makes the Prime Recipient legally responsible for paying the entire cost share. The Prime Recipient's cost share obligation is expressed in the funding agreement as a static amount in U.S. dollars (cost share amount) and as a percentage of the Total Project Cost (cost share percentage). If the funding agreement is terminated prior to the end of the period of performance, the Prime Recipient is required to contribute at least the cost share percentage of total expenditures incurred through the date of termination.

The Prime Recipient is solely responsible for managing cost share contributions by the Project Team and enforcing cost share obligations assumed by Project Team members in subawards or related agreements.

#### **5. COST SHARE ALLOCATION**

Each Project Team is free to determine how much each Project Team member will contribute towards the cost share requirement. The amount contributed by individual Project Team members may vary, as long as the cost share requirement for the project as a whole is met.

---

<sup>14</sup> See the information provided in previous footnote.

## 6. COST SHARE TYPES AND ALLOWABILITY

Every cost share contribution must be allowable under the applicable Federal cost principles, as described in Section IV.G.1 of the FOA.

Project Teams may provide cost share in the form of cash or in-kind contributions. Cash contributions may be provided by the Prime Recipient or Subrecipients. Allowable in-kind contributions include but are not limited to personnel costs, indirect costs, facilities and administrative costs, rental value of buildings or equipment, and the value of a service, other resource, or third party in-kind contribution. Project Teams may use funding or property received from state or local governments to meet the cost share requirement, so long as the funding or property was not provided to the state or local government by the Federal Government.

The Prime Recipient may not use the following sources to meet its cost share obligations:

- Revenues or royalties from the prospective operation of an activity beyond the period of performance;
- Proceeds from the prospective sale of an asset of an activity;
- Federal funding or property (e.g., Federal grants, equipment owned by the Federal Government); or
- Expenditures that were reimbursed under a separate Federal program.

In addition, Project Teams may not use independent research and development (IR&D) funds<sup>15</sup> to meet their cost share obligations under cooperative agreements. However, Project Teams may use IR&D funds to meet their cost share obligations under Technology investment Agreements.

Project Teams may not use the same cash or in-kind contributions to meet cost share requirements for more than one project or program.

Cost share contributions must be specified in the project budget, verifiable from the Prime Recipient's records, and necessary and reasonable for proper and efficient accomplishment of the project. Every cost share contribution must be reviewed and approved in advance by the Contracting Officer and incorporated into the project budget before the expenditures are incurred.

---

<sup>15</sup> As defined in Federal Acquisition Regulation Subsection 31.205-18.

Applicants may wish to refer to 2 C.F.R. Parts 200 and 910, and 10 C.F.R Part 603 for additional guidance on cost sharing, specifically 2 C.F.R. §§ 200.306 and 910.130, and 10 C.F.R. §§ 603.525-555.

## **7. COST SHARE CONTRIBUTIONS BY FFRDCs AND GOGOs**

Because FFRDCs are funded by the Federal Government, costs incurred by FFRDCs generally may not be used to meet the cost share requirement. FFRDCs may contribute cost share only if the contributions are paid directly from the contractor's Management Fee or a non-Federal source.

Because GOGOs/Federal Agencies are funded by the Federal Government, GOGOs/Federal Agencies may not provide cost share for the proposed project. However, the GOGO/Agency costs would be included in Total Project Costs for purposes of calculating the cost-sharing requirements of the applicant.

## **8. COST SHARE VERIFICATION**

Upon selection for award negotiations, Applicants are required to provide information and documentation regarding their cost share contributions. Please refer to Section VI.B.3 of the FOA for guidance on the requisite cost share information and documentation.

### **C. OTHER**

#### **1. COMPLIANT CRITERIA**

Concept Papers are deemed compliant if:

- The Applicant meets the eligibility requirements in Section III.A of the FOA;
- The Concept Paper complies with the content and form requirements in Section IV.C of the FOA; and
- The Applicant entered all required information, successfully uploaded all required documents, and clicked the "Submit" button in ARPA-E eXCHANGE by the deadline stated in the FOA.

Concept Papers found to be noncompliant may not be merit reviewed or considered for award. ARPA-E will not review or consider noncompliant Concept Papers, including Concept Papers submitted through other means, Concept Papers submitted after the applicable deadline, and incomplete Concept Papers. A Concept Paper is incomplete if it does not include required

information. ARPA-E will not extend the submission deadline for Applicants that fail to submit required information and documents due to server/connection congestion.

Full Applications are deemed compliant if:

- The Applicant submitted a compliant and responsive Concept Paper;
- The Applicant meets the eligibility requirements in Section III.A of the FOA;
- The Full Application complies with the content and form requirements in Section IV.D of the FOA; and
- The Applicant entered all required information, successfully uploaded all required documents, and clicked the “Submit” button in ARPA-E eXCHANGE by the deadline stated in the FOA.

Full Applications found to be noncompliant may not be merit reviewed or considered for award. ARPA-E will not review or consider noncompliant Full Applications, including Full Applications submitted through other means, Full Applications submitted after the applicable deadline, and incomplete Full Applications. A Full Application is incomplete if it does not include required information and documents, such as Forms SF-424 and SF-424A. ARPA-E will not extend the submission deadline for Applicants that fail to submit required information and documents due to server/connection congestion.

Replies to Reviewer Comments are deemed compliant if:

- The Applicant successfully uploads its response to ARPA-E eXCHANGE by the deadline stated in the FOA.
- The Replies to Reviewer Comments comply with the content and form requirements of Section IV.E of the FOA.

ARPA-E will not review or consider noncompliant Replies to Reviewer Comments, including Replies submitted through other means and Replies submitted after the applicable deadline. ARPA-E will not extend the submission deadline for Applicants that fail to submit required information due to server/connection congestion. ARPA-E will review and consider each compliant and responsive Full Application, even if no Reply is submitted or if the Reply is found to be noncompliant.

## **2. RESPONSIVENESS CRITERIA**

ARPA-E performs a preliminary technical review of Concept Papers and Full Applications.

*Questions about this FOA? Check the Frequently Asked Questions available at <http://arpa-e.energy.gov/faq>. For questions that have not already been answered, email [ARPA-E-CO@hq.doe.gov](mailto:ARPA-E-CO@hq.doe.gov) (with FOA name and number in subject line); see FOA Sec. VII.A. Problems with ARPA-E eXCHANGE? Email [ExchangeHelp@hq.doe.gov](mailto:ExchangeHelp@hq.doe.gov) (with FOA name and number in subject line).*

The following types of submissions may be deemed nonresponsive and may not be reviewed or considered:

- Submissions that fall outside the technical parameters specified in this FOA.
- Submissions that do not address the required technical information (i.e. information that “must” be included), as specified in Sections I.D and I.E of the FOA.
- Submissions that have been submitted in response to other currently issued ARPA-E FOAs.
- Submissions that are not scientifically distinct from applications submitted in response to other currently issued ARPA-E FOAs.
- Submissions for basic research aimed solely at discovery and/or fundamental knowledge generation.
- Submissions for large-scale demonstration projects of existing technologies.
- Submissions for proposed technologies that represent incremental improvements to existing technologies.
- Submissions for proposed technologies that are not based on sound scientific principles (e.g., violates a law of thermodynamics).
- Submissions for proposed technologies that are not transformational, as described in Section I.A of the FOA.
- Submissions for proposed technologies that do not have the potential to become disruptive in nature, as described in Section I.A of the FOA. Technologies must be scalable such that they could be disruptive with sufficient technical progress.
- Submissions that are not scientifically distinct from existing funded activities supported elsewhere, including within the Department of Energy. Submissions that describe a technology but do not propose a R&D plan that allows ARPA-E to evaluate the submission under the applicable merit review criteria provided in Section V.A of the FOA.

### **3. SUBMISSIONS SPECIFICALLY NOT OF INTEREST**

Submissions that propose the following will be deemed nonresponsive and will not be merit reviewed or considered:

- Solutions that address thermal management issues in datacenters.
- Solutions to electrical energy conditioning distribution within datacenters.
- Solutions that address power delivery to datacenters.
- Electronic logic gate advances.
- Integrated circuit (server, switching, memory) advances.
- Datacenter networking or network element advances not directly related to the incorporation of integrated photonic interconnects and switching technologies.
- Submissions that do not explain how the proposed network design will leverage projected performance advantages of photonics-enabled sub-systems.
- Submissions for which the efficiency gains derive solely from future improvements in CPU, memory, or other datacenter electrical components or architectural efficiency

*Questions about this FOA? Check the Frequently Asked Questions available at <http://arpa-e.energy.gov/faq>. For questions that have not already been answered, email [ARPA-E-CO@hq.doe.gov](mailto:ARPA-E-CO@hq.doe.gov) (with FOA name and number in subject line); see FOA Sec. VII.A. Problems with ARPA-E eXCHANGE? Email [ExchangeHelp@hq.doe.gov](mailto:ExchangeHelp@hq.doe.gov) (with FOA name and number in subject line).*

enhancements (e.g., anticipated silicon CMOS scaling, or energy-proportional computing strategies).

- Optical computing concepts.

#### **4. LIMITATION ON NUMBER OF SUBMISSIONS**

ARPA-E is not limiting the number of submissions from Applicants. Applicants may submit more than one application to this FOA, provided that each application is scientifically distinct.

### **IV. APPLICATION AND SUBMISSION INFORMATION**

#### **A. APPLICATION PROCESS OVERVIEW**

##### **1. REGISTRATION IN ARPA-E eXCHANGE**

The first step in applying to this FOA is registration in ARPA-E eXCHANGE, ARPA-E's online application portal. For detailed guidance on using ARPA-E eXCHANGE, please refer to Section IV.H.1 of the FOA and the "ARPA-E eXCHANGE User Guide" (<https://arpa-e-foa.energy.gov/Manuals.aspx>).

##### **2. CONCEPT PAPERS**

Applicants must submit a Concept Paper by the deadline stated in the FOA. Section IV.C of the FOA provides instructions on submitting a Concept Paper.

ARPA-E performs a preliminary review of Concept Papers to determine whether they are compliant and responsive, as described in Section III.C of the FOA. Concept Papers found to be noncompliant or nonresponsive may not be merit reviewed or considered for award. ARPA-E makes an independent assessment of each compliant and responsive Concept Paper based on the criteria in Section V.A.1 of the FOA.

ARPA-E will encourage a subset of Applicants to submit Full Applications. Other Applicants will be discouraged from submitting a Full Application in order to save them the time and expense of preparing an application submission that is unlikely to be selected for award negotiations. By discouraging the submission of a Full Application, ARPA-E intends to convey its lack of programmatic interest in the proposed project. Such assessments do not necessarily reflect judgments on the merits of the proposed project. Unsuccessful Applicants should continue to submit innovative ideas and concepts to future FOAs.

*Questions about this FOA? Check the Frequently Asked Questions available at <http://arpa-e.energy.gov/faq>. For questions that have not already been answered, email [ARPA-E-CO@hq.doe.gov](mailto:ARPA-E-CO@hq.doe.gov) (with FOA name and number in subject line); see FOA Sec. VII.A. Problems with ARPA-E eXCHANGE? Email [ExchangeHelp@hq.doe.gov](mailto:ExchangeHelp@hq.doe.gov) (with FOA name and number in subject line).*

### **3. FULL APPLICATIONS**

Applicants must submit a Full Application by the deadline stated in the FOA. Applicants will have approximately ~~30~~ 45 days from receipt of the Encourage/Discourage notification to prepare and submit a Full Application. Section IV.D of the FOA provides instructions on submitting a Full Application.

ARPA-E performs a preliminary review of Full Applications to determine whether they are compliant and responsive, as described in Section III.C of the FOA. Full Applications found to be noncompliant or nonresponsive may not be merit reviewed or considered for award. ARPA-E makes an independent assessment of each compliant and responsive Full Application based on the criteria in Section V.A.2 of the FOA.

### **4. REPLY TO REVIEWER COMMENTS**

Once ARPA-E has completed its review of Full Applications, reviewer comments on compliant and responsive Full Applications are made available to Applicants via ARPA-E eXCHANGE. Applicants may submit an optional Reply to Reviewer Comments, which must be submitted by the deadline stated in the FOA. Section IV.E of the FOA provides instructions on submitting a Reply to Reviewer Comments.

ARPA-E performs a preliminary review of Replies to determine whether they are compliant, as described in Section III.C.1 of the FOA. ARPA-E will review and consider compliant Replies only. ARPA-E will review and consider each compliant and responsive Full Application, even if no Reply is submitted or if the Reply is found to be non-compliant.

### **5. PRE-SELECTION CLARIFICATIONS AND “DOWN-SELECT” PROCESS**

Once ARPA-E completes its review of Full Applications and Replies to Reviewer Comments, it may, at the Contracting Officer’s discretion, conduct a pre-selection clarification process and/or perform a “down-select” of Full Applications. Through the pre-selection clarification process or down-select process, ARPA-E may obtain additional information from select Applicants through pre-selection meetings, webinars, videoconferences, conference calls, written correspondence, or site visits that can be used to make a final selection determination. ARPA-E will not reimburse Applicants for travel and other expenses relating to pre-selection meetings and site visits, nor will these costs be eligible for reimbursement as pre-award costs.

ARPA-E may select applications for funding and make awards without pre-selection meetings and site visits. Participation in a pre-selection meeting or site visit with ARPA-E does not signify that Applicants have been selected for award negotiations.

### **6. SELECTION FOR AWARD NEGOTIATIONS**

Questions about this FOA? Check the Frequently Asked Questions available at <http://arpa-e.energy.gov/faq>. For questions that have not already been answered, email [ARPA-E-CO@hq.doe.gov](mailto:ARPA-E-CO@hq.doe.gov) (with FOA name and number in subject line); see FOA Sec. VII.A. Problems with ARPA-E eXCHANGE? Email [ExchangeHelp@hq.doe.gov](mailto:ExchangeHelp@hq.doe.gov) (with FOA name and number in subject line).

ARPA-E carefully considers all of the information obtained through the application process and makes an independent assessment of each compliant and responsive Full Application based on the criteria and program policy factors in Sections V.A.2 and V.B.1 of the FOA. The Selection Official may select all or part of a Full Application for award negotiations. The Selection Official may also postpone a final selection determination on one or more Full Applications until a later date, subject to availability of funds and other factors. ARPA-E will enter into award negotiations only with selected Applicants.

Applicants are promptly notified of ARPA-E's selection determination. ARPA-E may stagger its selection determinations. As a result, some Applicants may receive their notification letter in advance of other Applicants. Please refer to Section VI.A of the FOA for guidance on award notifications.

## **7. MANDATORY WEBINAR**

All selected Applicants, including the Principal Investigator and the financial manager for the project, are required to participate in a webinar that is held within approximately one week of the selection notification. During the webinar, ARPA-E officials present important information on the award negotiation process, including deadlines for the completion of certain actions.

### **B. APPLICATION FORMS**

Required forms for Full Applications are available on ARPA-E eXCHANGE (<https://arpa-e-foa.energy.gov>), including the SF-424 and Budget Justification Workbook/SF-424A. A sample Summary Slide is available on ARPA-E eXCHANGE. Applicants may use the templates available on ARPA-E eXCHANGE, including the template for the Concept Paper, the template for the Technical Volume of the Full Application, the template for the Summary Slide, the template for the Summary for Public Release, the template for the Reply to Reviewer Comments, and the template for the Business Assurances & Disclosures Form. A sample response to the Business Assurances & Disclosures Form is available on ARPA-E eXCHANGE.

### **C. CONTENT AND FORM OF CONCEPT PAPERS**

**The Concept Paper is mandatory** (i.e. in order to submit a Full Application, a compliant and responsive Concept Paper must have been submitted) and must conform to the following formatting requirements:

- The Concept Paper must not exceed 4 pages in length for partial solutions, or 6 pages in length for full solutions, including graphics, figures, tables, and/or references.
- The Concept Paper must be submitted in Adobe PDF format.



- The Concept Paper must be written in English.
- All pages must be formatted to fit on 8-1/2 by 11 inch paper with margins not less than one inch on every side. Single space all text and use Times New Roman typeface, a black font color, and a font size of 12 point or larger (except in figures and tables).
- The ARPA-E assigned Control Number, the Lead Organization Name, and the Principal Investigator's Last Name must be prominently displayed on the upper right corner of the header of every page. Page numbers must be included in the footer of every page.
- The first paragraph must include the Lead Organization's Name and Location, Principal Investigator's Name, Technical Category, Proposed Funding Requested (Federal and Cost Share), and Project Duration.

Concept Papers found to be noncompliant or nonresponsive may not be merit reviewed or considered for award (see Section III.C of the FOA).

Each Concept Paper must be limited to a single concept or technology. Unrelated concepts and technologies must not be consolidated into a single Concept Paper.

A fillable Concept Paper template is available on ARPA-E eXCHANGE at <https://arpa-e-foa.energy.gov>.

Concept Papers must conform to the content requirements described below. If Applicants exceed the maximum page length indicated above, ARPA-E will review only the authorized number of pages and disregard any additional pages:

## **1. CONCEPT PAPER**

### **a. CONCEPT SUMMARY**

- Describe the proposed concept with minimal jargon, and explain how it addresses the Program Objectives of the FOA.
- Specify if you are submitting a full solution or partial solution.
- Partial solutions are limited to 4 pages, full solutions are limited to 6 pages.
- All Concept Papers must describe Phase 1 and Phase 2 work, with Phase 1 in more detail.

Questions about this FOA? Check the Frequently Asked Questions available at <http://arpa-e.energy.gov/faq>. For questions that have not already been answered, email [ARPA-E-CO@hq.doe.gov](mailto:ARPA-E-CO@hq.doe.gov) (with FOA name and number in subject line); see FOA Sec. VII.A. Problems with ARPA-E eXCHANGE? Email [ExchangeHelp@hq.doe.gov](mailto:ExchangeHelp@hq.doe.gov) (with FOA name and number in subject line).

**b. INNOVATION AND IMPACT**

- Clearly identify the problem to be solved with the proposed technology concept.
- Describe how the proposed effort represents an innovative and potentially transformational solution to the technical challenges posed by the FOA.
- Explain the concept's potential to be disruptive compared to existing or emerging technologies.
- To the extent possible, provide quantitative metrics in a table that compares the proposed technology concept to current and emerging technologies and to the Technical Performance Targets in Section I.E of the FOA for the appropriate Technology Category in Section I.D of the FOA.

**c. PROPOSED WORK**

- Describe the final deliverable(s) for the project and the overall technical approach used to achieve project objectives. Applicants must address the deliverables listed in Section I.E of the FOA.
- Discuss alternative approaches considered, if any, and why the proposed approach is most appropriate for the project objectives.
- Describe the background, theory, simulation, modeling, experimental data, or other sound engineering and scientific practices or principles that support the proposed approach. Provide specific examples of supporting data and/or appropriate citations to the scientific and technical literature.
- Describe why the proposed effort is a significant technical challenge and the key technical risks to the project. Does the approach require one or more entirely new technical developments to succeed? How will technical risk be mitigated?
- Identify techno-economic challenges to be overcome for the proposed technology to be commercially relevant.

**d. TEAM ORGANIZATION AND CAPABILITIES**

- Indicate the roles and responsibilities of the organizations and key personnel that comprise the Project Team.

- Provide the name, position, and institution of each key team member and describe in 1-2 sentences the skills and experience that he/she brings to the team.
- Identify key capabilities provided by the organizations comprising the Project Team and how those key capabilities will be used in the proposed effort.
- Identify (if applicable) previous collaborative efforts among team members relevant to the proposed effort.

**D. CONTENT AND FORM OF FULL APPLICATIONS**

~~[TO BE INSERTED BY FOA MODIFICATION IN SEPTEMBER 2016]~~

Full Applications must conform to the following formatting requirements:

- Each document must be submitted in the file format prescribed below.
- The Full Application must be written in English.
- All pages must be formatted to fit on 8-1/2 by 11 inch paper with margins not less than one inch on every side. Single space all text and use Times New Roman typeface, a black font color, and a font size of 12 point or larger (except in figures and tables).
- The ARPA-E assigned Control Number, the Lead Organization Name, and the Principal Investigator's Last Name must be prominently displayed on the upper right corner of the header of every page. Page numbers must be included in the footer of every page.

Full Applications found to be noncompliant or nonresponsivemay not be merit reviewed or considered for award (see Section III.C of the FOA).

Each Full Application should be limited to a single concept or technology. Unrelated concepts and technologies should not be consolidated in a single Full Application.

Fillable Full Application template documents are available on ARPA-E eXCHANGE at <https://arpa-e-foa.energy.gov>.

Full Applications must conform to the content requirements described below.

Component	Required Format	Description and Information
-----------	-----------------	-----------------------------

Questions about this FOA? Check the Frequently Asked Questions available at <http://arpa-e.energy.gov/faq>. For questions that have not already been answered, email [ARPA-E-CO@hq.doe.gov](mailto:ARPA-E-CO@hq.doe.gov) (with FOA name and number in subject line); see FOA Sec. VII.A. Problems with ARPA-E eXCHANGE? Email [ExchangeHelp@hq.doe.gov](mailto:ExchangeHelp@hq.doe.gov) (with FOA name and number in subject line).

<b>Technical Volume</b>	PDF	The centerpiece of the Full Application. Provides a detailed description of the proposed R&D project and Project Team. A Technical Volume template is available on ARPA-E eXCHANGE ( <a href="https://arpa-e-foa.energy.gov">https://arpa-e-foa.energy.gov</a> ).
<b>SF-424</b>	PDF	Application for Federal Assistance ( <a href="https://arpa-e-foa.energy.gov">https://arpa-e-foa.energy.gov</a> ). Applicants are responsible for ensuring that the proposed costs listed in eXCHANGE match those listed on forms SF-424 and SF-424A. Inconsistent submissions may impact ARPA-E's final award determination.
<b>Budget Justification Workbook/SF-424A</b>	XLS	Budget Information – Non-Construction Programs ( <a href="https://arpa-e-foa.energy.gov">https://arpa-e-foa.energy.gov</a> )
<b>Summary for Public Release</b>	PDF	Short summary of the proposed R&D project. Intended for public release. A Summary for Public Release template is available on ARPA-E eXCHANGE ( <a href="https://arpa-e-foa.energy.gov">https://arpa-e-foa.energy.gov</a> ).
<b>Summary Slide</b>	PPT	A four-panel project slide summarizing different aspects of the proposed R&D project. A Summary Slide template is available on ARPA-E eXCHANGE ( <a href="https://arpa-e-foa.energy.gov">https://arpa-e-foa.energy.gov</a> ).
<b>Business Assurances &amp; Disclosures Form</b>	PDF	Requires the Applicant to make responsibility disclosures and disclose potential conflicts of interest within the Project Team. Requires the Applicant to describe the additionality and risks associated with the proposed project, disclose applications for funding currently pending with Federal and non-Federal entities, and disclose funding from Federal and non-Federal entities for work in the same technology area as the proposed R&D project. If the Applicant is a FFRDC/DOE Lab, requires the Applicant to provide written authorization from the cognizant Federal agency and, if a DOE/NNSA FFRDC/DOE Lab, a Field Work Proposal. Allows the Applicant to request a waiver or modification of the Performance of Work in the United States requirement and/or the Technology Transfer & Outreach (TT&O) spending requirement. This form is available on ARPA-E eXCHANGE at <a href="https://arpa-e-foa.energy.gov">https://arpa-e-foa.energy.gov</a> . A sample response to the Business Assurances & Disclosures Form is also available on ARPA-E eXCHANGE.
<b>U.S. Manufacturing Plan</b>	PDF	As part of the application, Applicants are required to submit a U.S. Manufacturing Plan. The U.S. Manufacturing Plan represents the Applicant's measurable commitment to support U.S. manufacturing as a result of its award. See detailed U.S. Manufacturing Plan instructions and examples in the Seventh Component description below.

ARPA-E provides detailed guidance on the content and form of each component below.

## 1. FIRST COMPONENT: TECHNICAL VOLUME

The Technical Volume must be submitted in Adobe PDF format. A Technical Volume template is available at <https://arpa-e-foa.energy.gov>. The Technical Volume must conform to the following content and form requirements, including maximum page lengths specified below. If Applicants exceed the maximum page lengths specified for each section indicated below, ARPA-E will review only the authorized number of pages and disregard any additional pages.

Questions about this FOA? Check the Frequently Asked Questions available at <http://arpa-e.energy.gov/faq>. For questions that have not already been answered, email [ARPA-E-CO@hq.doe.gov](mailto:ARPA-E-CO@hq.doe.gov) (with FOA name and number in subject line); see FOA Sec. VII.A. Problems with ARPA-E eXCHANGE? Email [ExchangeHelp@hq.doe.gov](mailto:ExchangeHelp@hq.doe.gov) (with FOA name and number in subject line).

Applicants must provide sufficient citations and references to the primary research literature to justify the claims and approaches made in the Technical Volume. ARPA-E and reviewers may review primary research literature in order to evaluate applications. However, ARPA-E and reviewers are under no obligation to review cited sources (e.g., Internet websites).

PAGE LIMIT	SECTION	DESCRIPTION
1 page max.	EXECUTIVE SUMMARY	<p>Summarize the objective(s) and technical approach of the proposed effort at a technical level appropriate for scientific and engineering peers.</p> <p><b>INSTRUCTIONS:</b></p> <ol style="list-style-type: none"> <li>(1) The Project Title should be brief and descriptive of the proposed technology.</li> <li>(2) Identify the most relevant Technical Category for the proposed technology from the “Technical Categories of Interest” in Section I.D of the FOA. Select only one Technical Category unless the FOA specifically allows applications to name multiple categories.</li> <li>(3) Enter the estimated Total Project Cost in U.S. dollars and percentage cost share in parentheses.</li> <li>(4) Enter the Project Duration in months.</li> <li>(5) The Executive Summary shall not exceed 1 page in length</li> <li>(6) The Executive Summary may contain graphics, figures, or tables as needed to summarize the technical concept.</li> </ol>
Sections 1-5 30 pages max.	Section 1 INNOVATION AND IMPACT	<p>Describe how the proposed work offers an innovative approach to achieve the program objectives of the FOA and how it will impact the mission areas of ARPA-E.</p> <p><b>1.1 Overall Description.</b></p> <ul style="list-style-type: none"> <li>• Describe the conceptual basis for the project and how the proposed technology works with minimal jargon.</li> <li>• Explain the objective(s) and performance characteristics of the proposed effort.</li> </ul> <p><b>1.2 Potential Impact.</b></p> <ul style="list-style-type: none"> <li>• Clearly identify the problem that is being solved with the proposed technology.</li> <li>• Describe how the proposed effort addresses one of the “Technical Categories of Interest” from Section I.D of the FOA.</li> <li>• Explain the project’s potential to be disruptive relative to the existing technology or how the project establishes a basis for new innovations.</li> </ul> <p><b>1.3 Innovativeness.</b></p> <ul style="list-style-type: none"> <li>• Describe how the proposed effort represents a new and innovative solution to the overall program challenge described in the FOA.</li> <li>• Indicate the technical goals and anticipated results, using appropriate metrics, for the project. Provide a description of how the metrics were derived, citing key previous results and/or assumptions.</li> <li>• Include and discuss, as appropriate, a table in which the targeted performance of the proposed technology is compared with the</li> </ul>

Questions about this FOA? Check the Frequently Asked Questions available at <http://arpa-e.energy.gov/faq>. For questions that have not already been answered, email [ARPA-E-CO@hq.doe.gov](mailto:ARPA-E-CO@hq.doe.gov) (with FOA name and number in subject line); see FOA Sec. VII.A. Problems with ARPA-E eXCHANGE? Email [ExchangeHelp@hq.doe.gov](mailto:ExchangeHelp@hq.doe.gov) (with FOA name and number in subject line).

		<p>“Technical Performance Targets” in Section I.E of the FOA and with other competing or emerging technologies that might achieve the FOA Technical Performance Targets.</p> <p><b>INSTRUCTIONS:</b></p> <p>(1) The Innovation and Impact Section may include figures, tables, and graphics.</p> <p>(2) The suggested length of the Innovation and Impact Section is 4 pages.</p>
	<p><b>Section 2 PROPOSED WORK</b></p>	<p>Describe and discuss for the proposed effort the technical background and approach, the R&amp;D tasks, and the key technical risks. This Section must justify the proposed approach as being appropriate to achieve the project’s objective(s).</p> <p><b>2.1 Approach.</b></p> <ul style="list-style-type: none"> <li>• Describe the technical approach and how this approach will achieve the proposed project objective(s).</li> <li>• Discuss alternative approaches considered, if any, and why the selected approach is most appropriate for the identified objective(s).</li> <li>• Describe the background, theory, simulation, modeling, experimental data, or other sound engineering and scientific practices or principles that support achieving the project objective(s). Provide specific examples of supporting data and/or appropriate citations to the scientific and technical literature.</li> </ul> <p><b>2.2 Technical Risk.</b></p> <ul style="list-style-type: none"> <li>• Identify potential technical issues and risks, e.g., the approach requires a never-before-demonstrated fabrication technique or greater-than-previously-demonstrated sub-component performance, etc.</li> <li>• Describe appropriate mitigation techniques and plans, if any, for each identified issue and risk.</li> </ul> <p><b>2.3 Schedule.</b></p> <ul style="list-style-type: none"> <li>• Provide a schedule for the proposed effort by major tasks, including major milestones or Go/No-Go decision points as appropriate. (<b><u>A Gantt chart is recommended.</u></b>)</li> </ul> <p><b>2.4 Task Descriptions for Phase 1 and Phase 2.</b></p> <ul style="list-style-type: none"> <li>• Identify and provide a full technical description for each main task in the proposed effort.</li> <li>• Discuss the reason the identified tasks are appropriate and sufficient for the identified approach.</li> <li>• Describe the key technical milestones and how these define the critical path for successful completion of the task.</li> </ul>

Questions about this FOA? Check the Frequently Asked Questions available at <http://arpa-e.energy.gov/faq>. For questions that have not already been answered, email [ARPA-E-CO@hq.doe.gov](mailto:ARPA-E-CO@hq.doe.gov) (with FOA name and number in subject line); see FOA Sec. VII.A. Problems with ARPA-E eXCHANGE? Email [ExchangeHelp@hq.doe.gov](mailto:ExchangeHelp@hq.doe.gov) (with FOA name and number in subject line).

		<ul style="list-style-type: none"> <li>Indicate how completion of each task relates to reducing technological uncertainty and achieving the overall project objective(s).</li> </ul> <p><b>INSTRUCTIONS:</b></p> <p>(1) The Proposed Work Section may include figures, tables, and graphics.  (2) The suggested length of the Proposed Work Section is 12 pages.</p>
	<p><b>Section 3 TEAM ORGANIZATION AND CAPABILITIES</b></p>	<p>Describe and discuss the, organization, capabilities, and management of the team and how these enable successful execution of the proposed effort.</p> <p><b>3.1 Organization.</b></p> <ul style="list-style-type: none"> <li>Indicate roles and responsibilities of the organizations on the proposed Project Team, e.g., subrecipient, consultant, subcontractor, or lead organization for each of the project tasks. Include relevant organization charts and teaming organization charts, as applicable.</li> <li>Identify Key Personnel, describe how their qualifications relate to the proposed effort, and indicate their roles and responsibilities for each of the project tasks.</li> <li>Identify previous collaborative efforts among team members if relevant to the proposed effort.</li> </ul> <p><b>3.2 Capabilities, Facilities, Equipment, and Information.</b></p> <ul style="list-style-type: none"> <li>Identify capabilities of the Applicant or proposed Project Team, e.g., relevant experience, previous or current R&amp;D efforts, or related government or commercial projects, that support the proposed effort.</li> <li>Identify all required facilities, equipment, and information for the proposed effort and discuss their adequacy and availability.</li> <li>Indicate any key equipment that must be fabricated or purchased.</li> </ul> <p><b>INSTRUCTIONS:</b></p> <p>(1) This Section may include figures, tables, and graphics.  (2) The suggested length of the Team Section is 4 pages.</p>
	<p><b>Section 4 TECHNOLOGY TO MARKET</b></p>	<p>The significant impact sought by ARPA-E depends upon successful projects finding a path to large-scale adoption. ARPA-E projects are not required to achieve commercial deployment by the end of the period of performance, but the agency asks the Applicant to define a reasonable path for the proposed technology toward commercial adoption.</p> <p><b>4.1 Technology to Market Strategy.</b></p> <ul style="list-style-type: none"> <li>Describe how the proposed technology is expected to transition from the lab to commercial deployment, including a description of the eventual product, potential near- and long-term market entries, likely commercialization approach (startup, license, etc.), specific organizations expected to be involved in the transition (partners, customers, etc.), and the commercialization timeline.</li> </ul>

Questions about this FOA? Check the Frequently Asked Questions available at <http://arpa-e.energy.gov/faq>. For questions that have not already been answered, email [ARPA-E-CO@hq.doe.gov](mailto:ARPA-E-CO@hq.doe.gov) (with FOA name and number in subject line); see FOA Sec. VII.A. Problems with ARPA-E eXCHANGE? Email [ExchangeHelp@hq.doe.gov](mailto:ExchangeHelp@hq.doe.gov) (with FOA name and number in subject line).



		<ul style="list-style-type: none"> <li>• Discuss manufacturing, cost, and scalability risks associated with the technology.</li> <li>• Describe anticipated resource needs for the next phase of development following the end of the ARPA-E project.</li> <li>• Explain why the proposed research is not being pursued by industry today.</li> <li>• Discuss the anticipated roles for the proposed research team in the commercialization of the technology.</li> </ul> <p><b>4.2 Intellectual Property.</b></p> <ul style="list-style-type: none"> <li>• Describe existing intellectual property, if any, that will be used to develop the new intellectual property; and</li> <li>• Discuss new intellectual property and data that is anticipated to be created as part of this effort, if any.</li> </ul> <p><b>INSTRUCTIONS:</b></p> <p>(1) The Technology to Market Section may include figures, tables, and graphics.</p> <p>(2) The suggested length of the Technology to Market Section is 4 pages.</p>																																										
	<p><b>Section 5 BUDGET</b></p>	<p>Indicate the budget, in US dollars, and provide a high-level budget summary, demonstrating that the budget is reasonable and appropriate for the proposed effort.</p> <p><b>5.1 Budget Breakdown for Phase 1 and Phase 2.</b></p> <p>Provide in tabular form following the template give below, a breakdown of the project budget by entity and major task in US dollars.</p> <table border="1" data-bbox="636 1253 1511 1566"> <thead> <tr> <th>Task Name</th> <th>[Prime]</th> <th>[Sub #1]</th> <th>[Sub #2]</th> <th>[Sub #3]</th> <th>[Sub #4]</th> <th>Total</th> </tr> </thead> <tbody> <tr> <td>[Task #1]</td> <td></td> <td></td> <td></td> <td></td> <td></td> <td></td> </tr> <tr> <td>[Task #2]</td> <td></td> <td></td> <td></td> <td></td> <td></td> <td></td> </tr> <tr> <td>[Task #3]</td> <td></td> <td></td> <td></td> <td></td> <td></td> <td></td> </tr> <tr> <td>Technology-to-Market</td> <td></td> <td></td> <td></td> <td></td> <td></td> <td></td> </tr> <tr> <td><b>Total</b></td> <td></td> <td></td> <td></td> <td></td> <td></td> <td></td> </tr> </tbody> </table> <p>Replace “Prime” with name of the primary (lead) entity and “Sub #n” with the name of the sub-recipient or sub-contractor entities, if applicable. Task names should clearly correspond to major tasks listed in Section 2.4. Expand or contract the table as needed to add/subtract entities (columns) or tasks (rows).</p> <p><b>5.2 Budget Summary.</b></p>	Task Name	[Prime]	[Sub #1]	[Sub #2]	[Sub #3]	[Sub #4]	Total	[Task #1]							[Task #2]							[Task #3]							Technology-to-Market							<b>Total</b>						
Task Name	[Prime]	[Sub #1]	[Sub #2]	[Sub #3]	[Sub #4]	Total																																						
[Task #1]																																												
[Task #2]																																												
[Task #3]																																												
Technology-to-Market																																												
<b>Total</b>																																												

Questions about this FOA? Check the Frequently Asked Questions available at <http://arpa-e.energy.gov/faq>. For questions that have not already been answered, email [ARPA-E-CO@hq.doe.gov](mailto:ARPA-E-CO@hq.doe.gov) (with FOA name and number in subject line); see FOA Sec. VII.A. Problems with ARPA-E eXCHANGE? Email [ExchangeHelp@hq.doe.gov](mailto:ExchangeHelp@hq.doe.gov) (with FOA name and number in subject line).

		<p>Provide a high-level summary for the project by major budget category, including at least these three:</p> <ul style="list-style-type: none"> <li>• Key Personnel and technical staff to be utilized (e.g., scientists, engineers, technicians, postdocs, graduate students, etc.)</li> <li>• Equipment</li> <li>• Materials and Supplies</li> </ul> <p><b>5.3 Cost Share.</b></p> <p>Provide a description of the cost share by value of the contribution (in dollars) and percentage of the Total Project Cost (TPC):</p> <ul style="list-style-type: none"> <li>• List each source of cost share, the type of contribution (cash or in-kind), the value of the contribution (in dollars), and the value as a percentage of TPC.</li> <li>• For all in-kind contributions, provide a detailed description of the contribution and its relevance to the project objectives</li> </ul> <p><b>INSTRUCTIONS:</b></p> <p>(1) The Budget Section may include figures, tables, and graphics.  (2) The suggested length of the Budget Section is 4 pages.</p>
<p><b>No page limit</b></p>	<p><b>REFERENCES</b></p>	<p>Provide a list of references appropriate to Sections 1-5.</p> <p><b>INSTRUCTIONS:</b></p> <p>(1) Only bibliographic information may be contained in the references. No additional text or commentary is allowed.  (2) There is no page limit for the Bibliographic References Section, which is outside of the overall 30-page limit for Sections 1-5.</p>
<p><b>Each PQS limited to 3 pages in length, no cumulative page limit</b></p>	<p><b>PERSONAL QUALIFICATION SUMMARIES</b></p>	<p>A Personal Qualification Summary (PQS) is required for the PI and all other Key Personnel. Each PQS must include a description of the following only:</p> <ul style="list-style-type: none"> <li>• Education and training</li> <li>• Employment history</li> <li>• Awards and honors</li> <li>• A list of no more than 10 peer-reviewed publications related to the proposed project</li> <li>• A list of no more than 10 other peer-reviewed publications demonstrating capabilities in the broad field</li> <li>• A list of no more than 10 non-peer-reviewed publications and patents demonstrating capabilities in the broad field</li> </ul> <p><b>INSTRUCTIONS:</b></p>

Questions about this FOA? Check the Frequently Asked Questions available at <http://arpa-e.energy.gov/faq>. For questions that have not already been answered, email [ARPA-E-CO@hq.doe.gov](mailto:ARPA-E-CO@hq.doe.gov) (with FOA name and number in subject line); see FOA Sec. VII.A. Problems with ARPA-E eXCHANGE? Email [ExchangeHelp@hq.doe.gov](mailto:ExchangeHelp@hq.doe.gov) (with FOA name and number in subject line).

		(1) Each Personal Qualification Summary is limited to 3 pages in length and there is no page limit for this Section, which is outside of the 30-page limit for Sections 1-5. (2) Curriculum Vitae should not be submitted.
--	--	---

## 2. SECOND COMPONENT: SF-424

The SF-424 must be submitted in Adobe PDF format. This form is available on ARPA-E eXCHANGE at <https://arpa-e-foa.energy.gov>.

The SF-424 includes instructions for completing the form. Applicants are required to complete all required fields in accordance with the instructions.

Prime Recipients and Subrecipients are required to complete SF-LLL (Disclosure of Lobbying Activities), available at <http://www.whitehouse.gov/sites/default/files/omb/grants/sflllin.pdf>, if any non-Federal funds have been paid or will be paid to any person for influencing or attempting to influence an officer or employee of any Federal agency, a Member of Congress, an officer or employee of Congress, or an employee of a Member of Congress in connection with your application or funding agreement. The completed SF-LLL must be appended to the SF-424.

ARPA-E provides the following supplemental guidance on completing the SF-424:

- Each Project Team should submit only one SF-424 (i.e., a Subrecipient should not submit a separate SF-424).
- Assume a project start date of June 2017, or as negotiated.
- The list of certifications and assurances in Block 21 can be found at <http://energy.gov/management/downloads/certifications-and-assurances-use-sf-424>.
- The dates and dollar amounts on the SF-424 are for Phase 1 and Phase 2 combined, not a portion thereof.
- Applicants are responsible for ensuring that the proposed costs listed in eXCHANGE match those listed on forms SF-424 and SF-424A. Inconsistent submissions may impact ARPA-E's final award determination.

Questions about this FOA? Check the Frequently Asked Questions available at <http://arpa-e.energy.gov/faq>. For questions that have not already been answered, email [ARPA-E-CO@hq.doe.gov](mailto:ARPA-E-CO@hq.doe.gov) (with FOA name and number in subject line); see FOA Sec. VII.A. Problems with ARPA-E eXCHANGE? Email [ExchangeHelp@hq.doe.gov](mailto:ExchangeHelp@hq.doe.gov) (with FOA name and number in subject line).

### 3. THIRD COMPONENT: BUDGET JUSTIFICATION WORKBOOK/SF-424A

Applicants are required to complete the Budget Justification Workbook/SF-424A Excel spreadsheet. This form is available on ARPA-E eXCHANGE at <https://arpa-e-foa.energy.gov>. Prime Recipients must complete each tab of the Budget Justification Workbook for Phase 1 and Phase 2, including all work to be performed by the Prime Recipient and its Subrecipients and Contractors. The SF-424A form included with the Budget Justification Workbook will “auto-populate” as the Applicant enters information into the Workbook. Applicants should carefully read the “Instructions and Summary” tab provided within the Budget Justification Workbook.

Subrecipient information must be submitted as follows:

- Each Subrecipient incurring greater than or equal to 10% of the Total Project Cost must complete a separate Budget Justification workbook to justify its proposed budget. These worksheets must be inserted as additional sheets within in the Prime Recipient’s Budget Justification.
- Subrecipients incurring less than 10% of the Total Project Cost are not required to complete a separate Budget Justification workbook. However, such Subrecipients are required to provide supporting documentation to justify their proposed budgets. At a minimum, the supporting documentation must show which tasks/subtasks are being performed, the purpose/need for the effort, and a sufficient basis for the estimated costs.

ARPA-E provides the following supplemental guidance on completing the Budget Justification Workbook/SF-424A:

- Applicants may request funds under the appropriate object class category tabs as long as the item and amount requested are necessary to perform the proposed work, meet all the criteria for allowability under the applicable Federal cost principles, and are not prohibited by the funding restrictions described herein.
- If Patent costs are requested, they must be included in the Applicant’s proposed budget (see Section IV.G.3 of the FOA for more information on Patent Costs).
- Unless a waiver is granted by ARPA-E, each Project Team must spend at least 5% of the Federal funding (i.e., the portion of the award that does not include the recipient’s cost share) on Technology Transfer & Outreach (TT&O) activities to promote and further the development and deployment of ARPA-E-funded technologies.
- All TT&O costs requested must be included in the Applicant’s proposed budget and identified as TT&O costs in the Budget Justification Workbook/SF-424A with the costs being requested under the “Other” budget category. All budgeted activities must relate

Questions about this FOA? Check the Frequently Asked Questions available at <http://arpa-e.energy.gov/faq>. For questions that have not already been answered, email [ARPA-E-CO@hq.doe.gov](mailto:ARPA-E-CO@hq.doe.gov) (with FOA name and number in subject line); see FOA Sec. VII.A. Problems with ARPA-E eXCHANGE? Email [ExchangeHelp@hq.doe.gov](mailto:ExchangeHelp@hq.doe.gov) (with FOA name and number in subject line).

to achieving specific objectives, technical milestones and deliverables outlined in Section 2.4 Task Descriptions of the Technical Volume.

- For pricing purposes, assume a project start date of June 2017, or as negotiated.
- For more information, please refer to the ARPA-E Budget Justification Guidance document at <https://arpa-e-foa.energy.gov>.

#### 4. FOURTH COMPONENT: SUMMARY FOR PUBLIC RELEASE

Applicants are required to provide a 250 word maximum Summary for Public Release. A Summary for Public Release template is available on ARPA-E eXCHANGE (<https://arpa-e-foa.energy.gov>). The Summary for Public Release must be submitted in Adobe PDF format. This summary should not include any confidential, proprietary, or privileged information. The summary should be written for a lay audience (e.g., general public, media, Congress) using plain English.

250 Words	SUMMARY FOR PUBLIC RELEASE	<p>Briefly describe the proposed effort, summarize its objective(s) and technical approach, describe its ability to achieve the “Program Objectives” (see Section I.C of the FOA), and indicate its potential impact on “ARPA-E Mission Areas” (see Section I.A of the FOA). The summary should be written at technical level suitable for a high-school science student and is designed for public release.</p> <p><b>INSTRUCTIONS:</b></p> <p>(1) The Summary for Public Release shall not exceed 250 words and one paragraph.</p> <p>(2) The Summary for Public Release shall consist only of text—no graphics, figures, or tables.</p> <p>(3) For applications selected for award negotiations, the Summary may be used as the basis for a public announcement by ARPA-E; therefore, <b>this Cover Page and Summary should not contain confidential or proprietary information</b>. See Section VIII.E of the FOA for additional information on marking confidential information</p>
-----------	----------------------------	--

#### 5. FIFTH COMPONENT: SUMMARY SLIDE

Applicants are required to provide a single PowerPoint slide summarizing the proposed project. The slide must be submitted in Microsoft PowerPoint format. This slide will be used during ARPA-E’s evaluation of Full Applications. A summary slide template and a sample summary slide are available on ARPA-E eXCHANGE (<https://arpa-e-foa.energy.gov>). Summary Slides must conform to the content requirements described below:

- A Technology Summary;

Questions about this FOA? Check the Frequently Asked Questions available at <http://arpa-e.energy.gov/faq>. For questions that have not already been answered, email [ARPA-E-CO@hq.doe.gov](mailto:ARPA-E-CO@hq.doe.gov) (with FOA name and number in subject line); see FOA Sec. VII.A. Problems with ARPA-E eXCHANGE? Email [ExchangeHelp@hq.doe.gov](mailto:ExchangeHelp@hq.doe.gov) (with FOA name and number in subject line).

- Bullet points that describe novel aspects of the proposed technology and technology approach;
- A description of the technology's impact;
  - Quantitative description (through text or graphic) of the impact the proposed project will provide to the market and ARPA-E mission areas;
- Proposed Targets;
  - Including any important technical performance metrics and/or impact categories;
  - Including quantitative description of the state of the art;
  - Including quantitative descriptions of the proposed targets;
- Any key graphics (illustrations, charts and/or tables) summarizing technology development and/or impact;
- The project's key idea/takeaway;
- Project title and Principal Investigator information; and
- Requested ARPA-E funds and proposed Applicant cost share.

## **6. SIXTH COMPONENT: BUSINESS ASSURANCES & DISCLOSURES FORM**

Applicants are required to provide the information requested in the Business Assurances & Disclosures Form. The information must be submitted in Adobe PDF format. A fillable Business Assurances & Disclosures Form template is available on ARPA-E eXCHANGE at <https://arpa-e-foa.energy.gov>. A sample response to the Business Assurances & Disclosures Form is also available on ARPA-E eXCHANGE.

As described in the Business Assurances & Disclosures Form, the Applicant is required to:

- Disclose conditions bearing on responsibility, such as criminal convictions and Federal tax liability;
- Disclose potential conflicts of interest within the Project Team;
- If the Applicant is a FFRDC/DOE Lab, submit written authorization from the cognizant Federal agency; and
- If the Applicant is a DOE/NNSA FFRDC/DOE Lab, submit a Field Work Proposal.

In addition, ARPA-E is required by statute to “accelerat[e] transformational technological advances in areas that industry is by itself not likely to undertake because of technical and financial uncertainty.”<sup>16</sup> In accordance with ARPA-E’s statutory mandate, the Applicant is required to:

---

<sup>16</sup> America COMPETES Act, Pub. L. No. 110-69, § 5012 (2007), as amended (codified at 42 U.S.C. § 16538).

- Describe the additionality and risks associated with the proposed R&D project;
- Disclose any applications for the same project or related work currently pending with any Federal or non-Federal entities; and
- Disclose all funding for work in the same technology area as the proposed project received from any Federal or non-Federal entity within the last 5 years.

Finally, the Applicant may use the Business Assurances & Disclosures Form to:

- Request authorization to perform some work overseas; and
- Request a waiver of the TT&O spending requirement.

## 7. SEVENTH COMPONENT: U.S. MANUFACTURING PLAN

As part of the application, Applicants are required to submit a U.S. Manufacturing Plan that should not exceed one page in length. The U.S. Manufacturing Plan represents the Applicant's measurable commitment to support U.S. manufacturing as a result of its award. U.S. Manufacturing Plans are a Program Policy Factor during the review and selection process. See Section V.B.1 of the FOA.

A U.S. Manufacturing Plan should contain the following or similar preamble: "If selected for funding, the Applicant agrees to the following commitments as a condition of that funding:" and, after the preamble, the plan should include one or more specific and measurable commitments. For example, an Applicant may commit particular types of products to be manufactured in the U.S. **These plans should not include requirements regarding the source of inputs used during the manufacturing process.** In addition to or instead of making a commitment tied to a particular product, the Applicant may make other types of commitments still beneficial to U.S. manufacturing. An Applicant may commit to a particular investment in a new or existing U.S. manufacturing facility, keep certain activities based in the U.S. (i.e., final assembly) or support a certain number of jobs in the U.S. related to the technology and manufacturing. For an Applicant which is likely to license the technology to others, especially universities for which licensing may be the exclusive means of commercialization the technology, the U.S. manufacturing plan may indicate the Applicant's plan and commitment to use a licensing strategy **for both exclusive and nonexclusive licensing** that would likely support U.S. manufacturing.

When an Applicant that is a domestic small business, domestic educational institution, or nonprofit organization is selected for an award, the U.S. Manufacturing Plan submitted by the Applicant may become part of the terms and conditions of the award **in addition to the requirements attaching to subject inventions described in VI.B.8 below.** The Applicant/Awardee may request a waiver or modification of the U.S. Manufacturing Plan from

Questions about this FOA? Check the Frequently Asked Questions available at <http://arpa-e.energy.gov/faq>. For questions that have not already been answered, email [ARPA-E-CO@hq.doe.gov](mailto:ARPA-E-CO@hq.doe.gov) (with FOA name and number in subject line); see FOA Sec. VII.A. Problems with ARPA-E eXCHANGE? Email [ExchangeHelp@hq.doe.gov](mailto:ExchangeHelp@hq.doe.gov) (with FOA name and number in subject line).

DOE upon a showing that the original U.S. Manufacturing Plan is no longer economically feasible.

Class patent waivers usually apply to domestic large businesses, as set forth in Section VIII.F. Under this class patent waiver, domestic large businesses may elect title to their subject inventions similar to the right provided to the domestic small businesses, educational institutions, and nonprofits by law. In order to avail itself of the class patent waiver, a domestic large business must agree that any products embodying or produced through the use of an invention conceived or first actually reduced to practice under the award will be substantially manufactured in the United States, unless DOE agrees that the commitments proposed in the U.S. Manufacturing Plan are sufficient. The U.S. Manufacturing Plan submitted by the Applicant may become part of the terms and conditions of the award **in addition to the requirements attaching to subject inventions.**

## **E. CONTENT AND FORM OF REPLIES TO REVIEWER COMMENTS**

[TO BE INSERTED BY FOA MODIFICATION IN SEPTEMBER 2016]

Written feedback on Full Applications is made available to Applicants before the submission deadline for Replies to Reviewer Comments. Applicants have a brief opportunity to prepare a short Reply to Reviewer Comments responding to one or more comments or supplementing their Full Application. A fillable Reply to Reviewer Comments template is available on ARPA-E eXCHANGE (<https://arpa-e-foa.energy.gov>).

Replies to Reviewer Comments must conform to the following requirements:

- The Reply to Reviewer Comments must be submitted in Adobe PDF format.
- The Reply to Reviewer Comments must be written in English.
- 1. All pages must be formatted to fit on 8-1/2 by 11 inch paper with margins not less than one inch on every side. Use Times New Roman typeface, a black font color, and a font size of 12 points or larger (except in figures and tables).
- The Control Number must be prominently displayed on the upper right corner of the header of every page. Page numbers must be included in the footer of every page.

ARPA-E may not review or consider noncompliant Replies to Reviewer Comments (see Section III.C.1 of the FOA). ARPA-E will review and consider each compliant and responsive Full Application, even if no Reply is submitted or if the Reply is found to be noncompliant.

Questions about this FOA? Check the Frequently Asked Questions available at <http://arpa-e.energy.gov/faq>. For questions that have not already been answered, email [ARPA-E-CO@hq.doe.gov](mailto:ARPA-E-CO@hq.doe.gov) (with FOA name and number in subject line); see FOA Sec. VII.A. Problems with ARPA-E eXCHANGE? Email [ExchangeHelp@hq.doe.gov](mailto:ExchangeHelp@hq.doe.gov) (with FOA name and number in subject line).



Replies to Reviewer Comments must conform to the following content and form requirements, including maximum page lengths, described below. If a Reply to Reviewer Comments is more than three pages in length, ARPA-E will review only the first three pages and disregard any additional pages.

SECTION	PAGE LIMIT	DESCRIPTION
Text	2 pages maximum	<ul style="list-style-type: none"><li>Applicants may respond to one or more reviewer comments or supplement their Full Application.</li></ul>
Images	1 page maximum	<ul style="list-style-type: none"><li>Applicants may provide graphs, charts, or other data to respond to reviewer comments or supplement their Full Application.</li></ul>

## F. INTERGOVERNMENTAL REVIEW

This program is not subject to Executive Order 12372 (Intergovernmental Review of Federal Programs).

## G. FUNDING RESTRICTIONS

[TO BE INSERTED BY FOA MODIFICATION IN SEPTEMBER 2016]

### 1. ALLOWABLE COSTS

All expenditures must be allowable, allocable, and reasonable in accordance with the applicable Federal cost principles. ARPA-E has listed the Federal cost principles for different categories of Applicants at <http://arpa-e.energy.gov/arpa-e-site-page/post-award-guidance>.

### 2. PRE-AWARD COSTS

ARPA-E will not reimburse any pre-award costs incurred by Applicants before they are selected for award negotiations. Please refer to Section VI.A of the FOA for guidance on award notices.

Upon selection for award negotiations, Applicants may incur pre-award costs at their own risk, consistent with the requirements in 2 C.F.R. Part 200, as modified by 2 C.F.R. Part 910, and other Federal laws and regulations. ARPA-E generally does not accept budgets as submitted with the Full Application. Budgets are typically reworked during award negotiations. ARPA-E is under no obligation to reimburse pre-award costs if, for any reason, the Applicant does not receive an award or the award is made for a lesser amount than the Applicant expected, or if the costs incurred are not allowable, allocable, or reasonable.

Questions about this FOA? Check the Frequently Asked Questions available at <http://arpa-e.energy.gov/faq>. For questions that have not already been answered, email [ARPA-E-CO@hq.doe.gov](mailto:ARPA-E-CO@hq.doe.gov) (with FOA name and number in subject line); see FOA Sec. VII.A. Problems with ARPA-E eXCHANGE? Email [ExchangeHelp@hq.doe.gov](mailto:ExchangeHelp@hq.doe.gov) (with FOA name and number in subject line).

Pre-award costs expected to exceed \$100,000 or incurred more than 90 days before the date of the Award require the written authorization of the ARPA-E Contracting Officer.

Please refer to the “Applicants’ Guide to ARPA-E Award Negotiations” ([http://arpa-e.energy.gov/sites/default/files/Award\\_Negotiations\\_Guide%20%20March%202015.pdf](http://arpa-e.energy.gov/sites/default/files/Award_Negotiations_Guide%20%20March%202015.pdf)) for additional guidance on pre-award costs.

### **3. PATENT COSTS**

For Subject Inventions disclosed to DOE under an award, ARPA-E will reimburse the Prime Recipient – in addition to allowable costs associated with Subject Invention disclosures - up to \$30,000 of expenditures for filing and prosecution of United States patent applications, including international applications (“PCT application”) submitted to the USPTO.

The Prime Recipient may request a waiver of the \$30,000 cap. Because all patent costs are considered to be Technology Transfer & Outreach (TT&O) costs (see Section IV.G.8 of the FOA below), the waiver request is subject to approval by the ARPA-E Program Director and Contracting Officer.

### **4. CONSTRUCTION**

ARPA-E generally does not fund projects that involve major construction. Recipients are required to obtain written authorization from the Contracting Officer before incurring any major construction costs.

### **5. FOREIGN TRAVEL**

ARPA-E generally does not fund projects that involve foreign travel. Recipients are required to obtain written authorization from the Contracting Officer before incurring any foreign travel costs and provide trip reports with their reimbursement requests.

### **6. PERFORMANCE OF WORK IN THE UNITED STATES**

ARPA-E strongly encourages interdisciplinary and cross-sectoral collaboration spanning organizational boundaries. Such collaboration enables the achievement of scientific and technological outcomes that were previously viewed as extremely difficult, if not impossible.

ARPA-E requires all work under ARPA-E funding agreements to be performed in the United States – i.e., Prime Recipients must expend 100% of the Total Project Cost in the United States. However, Applicants may request a waiver of this requirement where their project would materially benefit from, or otherwise requires, certain work to be performed overseas.

Applicants seeking a waiver of this requirement are required to include an explicit request in

Questions about this FOA? Check the Frequently Asked Questions available at <http://arpa-e.energy.gov/faq>. For questions that have not already been answered, email [ARPA-E-CO@hq.doe.gov](mailto:ARPA-E-CO@hq.doe.gov) (with FOA name and number in subject line); see FOA Sec. VII.A. Problems with ARPA-E eXCHANGE? Email [ExchangeHelp@hq.doe.gov](mailto:ExchangeHelp@hq.doe.gov) (with FOA name and number in subject line).

the Business Assurances & Disclosures Form, which is part of the Full Application submitted to ARPA-E. Such waivers are granted where there is a demonstrated need, as determined by ARPA-E.

## **7. PURCHASE OF NEW EQUIPMENT**

All equipment purchased under ARPA-E funding agreements must be made or manufactured in the United States, to the maximum extent practicable. This requirement does not apply to used or leased equipment. The Prime Recipients are required to notify the ARPA-E Contracting Officer reasonably in advance of purchasing any equipment that is not made or manufactured in the United States with an acquisition cost of \$25,000 or more per unit. The ARPA-E Contracting Officer will provide consent to purchase or reject within 30 calendar days of receipt of the Recipient's notification.

## **8. TECHNOLOGY TRANSFER AND OUTREACH**

ARPA-E is required to contribute a percentage of appropriated funds to Technology Transfer and Outreach (TT&O) activities. In order to meet this mandate every Project Team must spend at least 5% of the Federal funding (i.e., the portion of the award that does not include the recipient's cost share) provided by ARPA-E on TT&O activities to promote and further the development and deployment of ARPA-E-funded technologies. Project Teams must also seek a waiver from ARPA-E to spend less than the minimum 5% TT&O expenditure requirement.

All TT&O expenditures are subject to the applicable Federal cost principles (i.e., 2 C.F.R. 200 Subpart E and 48 C.F.R. Subpart 31). Examples of TT&O expenditures are as follows:

- Documented travel and registration for the ARPA-E Energy Innovation Summit and other energy-related conferences and events;
- Documented travel to meet with potential suppliers, partners, or customers;
- Documented work by salaried or contract personnel to develop technology-to-market models or plans;
- Documented costs of acquiring industry-accepted market research reports; and
- Approved patent costs.

ARPA-E will not reimburse recipients for TT&O costs considered to be unallowable in accordance with the applicable cost principles. Examples of unallowable TT&O expenditures include:

- Meals or entertainment;

Questions about this FOA? Check the Frequently Asked Questions available at <http://arpa-e.energy.gov/faq>. For questions that have not already been answered, email [ARPA-E-CO@hq.doe.gov](mailto:ARPA-E-CO@hq.doe.gov) (with FOA name and number in subject line); see FOA Sec. VII.A. Problems with ARPA-E eXCHANGE? Email [ExchangeHelp@hq.doe.gov](mailto:ExchangeHelp@hq.doe.gov) (with FOA name and number in subject line).

- Gifts to potential suppliers, partners, or customers;
- TT&O activities that do not relate to the ARPA-E-funded technologies;
- Undocumented TT&O activities; and
- TT&O activities unrelated and/or unallocable to the subject award.

Applicants may seek a waiver of the TT&O requirement by including an explicit request in the Business Assurances & Disclosures Form. Please refer to the Business Assurances & Disclosures Form for guidance on the content and form of the waiver request. ARPA-E may waive or modify the TT&O requirement, as appropriate.

For information regarding incorporation of TT&O costs into budget documentation, see Section IV.D.3 of the FOA.

Please refer to the “Applicants’ Guide to ARPA-E Award Negotiations” ([http://arpa-e.energy.gov/sites/default/files/Award\\_Negotiations\\_Guide%20%20March%202015.pdf](http://arpa-e.energy.gov/sites/default/files/Award_Negotiations_Guide%20%20March%202015.pdf)) for additional guidance on TT&O requirements.

## 9. LOBBYING

Prime Recipients and Subrecipients may not use any Federal funds, directly or indirectly, to influence or attempt to influence, directly or indirectly, congressional action on any legislative or appropriation matters pending before Congress, other than to communicate to Members of Congress as described in 18 U.S.C. § 1913. This restriction is in addition to those prescribed elsewhere in statute and regulation.

Prime Recipients and Subrecipients are required to complete and submit SF-LLL, “Disclosure of Lobbying Activities” (<http://www.whitehouse.gov/sites/default/files/omb/grants/sflllin.pdf>) if any non-Federal funds have been paid or will be paid to any person for influencing or attempting to influence any of the following in connection with your application:

- An officer or employee of any Federal agency,
- A Member of Congress,
- An officer or employee of Congress, or
- An employee of a Member of Congress.

## 10. CONFERENCE SPENDING

Prime Recipients and Subrecipients may not use any Federal funds to:

- Defray the cost to the United States Government of a conference held by any Executive branch department, agency, board, commission, or office which is not directly and programmatically related to the purpose for which their ARPA-E award is made and for which the cost to the United States Government is more than \$20,000; or
- To circumvent the required notification by the head of any such Executive Branch department, agency, board, commission, or office to the Inspector General (or senior ethics official for any entity without an Inspector General), of the date, location, and number of employees attending such a conference.

## 11. INDEPENDENT RESEARCH AND DEVELOPMENT COSTS

ARPA-E does not provide financial assistance or reimburse organizations for IR&D costs, or count IR&D costs as cost share, as defined at 48 C.F.R. § 31.205-18(a). Indirect cost rate proposals submitted to ARPA-E shall include IR&D costs in the direct cost base used to calculate the indirect rate(s) to ensure an appropriate allocation of indirect costs to the organization's direct cost centers.

### H. OTHER SUBMISSION REQUIREMENTS

#### 1. USE OF ARPA-E eXCHANGE

To apply to this FOA, Applicants must register with ARPA-E eXCHANGE (<https://arpa-e-foa.energy.gov/Registration.aspx>). Concept Papers, Full Applications, and Replies to Reviewer Comments must be submitted through ARPA-E eXCHANGE (<https://arpa-e-foa.energy.gov/login.aspx>). ARPA-E will not review or consider applications submitted through other means (e.g., fax, hand delivery, email, postal mail). For detailed guidance on using ARPA-E eXCHANGE, please refer to the "ARPA-E eXCHANGE User Guide" (<https://arpa-e-foa.energy.gov/Manuals.aspx>).

Upon creating an application submission in ARPA-E eXCHANGE, Applicants will be assigned a Control Number. If the Applicant creates more than one application submission, a different Control Number will be assigned for each application.

Once logged in to ARPA-E eXCHANGE (<https://arpa-e-foa.energy.gov/login.aspx>), Applicants may access their submissions by clicking the "My Submissions" link in the navigation on the left side of the page. Every application that the Applicant has submitted to ARPA-E and the

Questions about this FOA? Check the Frequently Asked Questions available at <http://arpa-e.energy.gov/faq>. For questions that have not already been answered, email [ARPA-E-CO@hq.doe.gov](mailto:ARPA-E-CO@hq.doe.gov) (with FOA name and number in subject line); see FOA Sec. VII.A. Problems with ARPA-E eXCHANGE? Email [ExchangeHelp@hq.doe.gov](mailto:ExchangeHelp@hq.doe.gov) (with FOA name and number in subject line).

corresponding Control Number is displayed on that page. If the Applicant submits more than one application to a particular FOA, a different Control Number is shown for each application.

Applicants are responsible for meeting each submission deadline in ARPA-E eXCHANGE.

**Applicants are strongly encouraged to submit their applications at least 48 hours in advance of the submission deadline.** Under normal conditions (i.e., at least 48 hours in advance of the submission deadline), Applicants should allow at least 1 hour to submit a Concept Paper, or Full Application. In addition, Applicants should allow at least 15 minutes to submit a Reply to Reviewer Comments. Once the application is submitted in ARPA-E eXCHANGE, Applicants may revise or update their application until the expiration of the applicable deadline.

**Applicants should not wait until the last minute to begin the submission process.** During the final hours before the submission deadline, Applicants may experience server/connection congestion that prevents them from completing the necessary steps in ARPA-E eXCHANGE to submit their applications. **ARPA-E will not extend the submission deadline for Applicants that fail to submit required information and documents due to server/connection congestion.**

**ARPA-E will not review or consider incomplete applications and applications received after the deadline stated in the FOA.** Such applications will be deemed noncompliant (see Section III.C.1 of the FOA). The following errors could cause an application to be deemed “incomplete” and thus noncompliant:

- Failing to comply with the form and content requirements in Section IV of the FOA;
- Failing to enter required information in ARPA-E eXCHANGE;
- Failing to upload required document(s) to ARPA-E eXCHANGE;
- Failing to click the “Submit” button in ARPA-E eXCHANGE by the deadline stated in the FOA;
- Uploading the wrong document(s) or application(s) to ARPA-E eXCHANGE; and
- Uploading the same document twice, but labeling it as different documents. (In the latter scenario, the Applicant failed to submit a required document.)

ARPA-E urges Applicants to carefully review their applications and to allow sufficient time for the submission of required information and documents.

## **V. APPLICATION REVIEW INFORMATION**

### **A. CRITERIA**

Questions about this FOA? Check the Frequently Asked Questions available at <http://arpa-e.energy.gov/faq>. For questions that have not already been answered, email [ARPA-E-CO@hq.doe.gov](mailto:ARPA-E-CO@hq.doe.gov) (with FOA name and number in subject line); see FOA Sec. VII.A. Problems with ARPA-E eXCHANGE? Email [ExchangeHelp@hq.doe.gov](mailto:ExchangeHelp@hq.doe.gov) (with FOA name and number in subject line).

ARPA-E performs a preliminary review of Concept Papers and Full Applications to determine whether they are compliant and responsive (see Section III.C of the FOA). ARPA-E also performs a preliminary review of Replies to Reviewer Comments to determine whether they are compliant.

ARPA-E considers a mix of quantitative and qualitative criteria in determining whether to encourage the submission of a Full Application and whether to select a Full Application for award negotiations.

## **1. CRITERIA FOR CONCEPT PAPERS**

(1) *Impact of the Proposed Technology Relative to FOA Targets* (50%) - This criterion involves consideration of the following:

- The potential for a transformational and disruptive (not incremental) advancement compared to existing or emerging technologies;
- Achievement of the technical performance targets defined in Section I.E of the FOA for the appropriate technology Category in Section I.D of the FOA; and
- Demonstration of awareness of competing commercial and emerging technologies and identifies how the proposed concept/technology provides significant improvement over existing solutions.

(2) *Overall Scientific and Technical Merit* (50%) - This criterion involves consideration of the following:

- The feasibility of the proposed work, as justified by appropriate background, theory, simulation, modeling, experimental data, or other sound scientific and engineering practices;
- Sufficiency of technical approach to accomplish the proposed R&D objectives, including why the proposed concept is more appropriate than alternative approaches and how technical risk will be mitigated;
- Clearly defined project outcomes and final deliverables;
- Identification of techno-economic challenges that must be overcome for the proposed technology to be commercially relevant; and
- The demonstrated capabilities of the individuals performing the project, the key capabilities of the organizations comprising the Project Team, the roles and

Questions about this FOA? Check the Frequently Asked Questions available at <http://arpa-e.energy.gov/faq>. For questions that have not already been answered, email [ARPA-E-CO@hq.doe.gov](mailto:ARPA-E-CO@hq.doe.gov) (with FOA name and number in subject line); see FOA Sec. VII.A. Problems with ARPA-E eXCHANGE? Email [ExchangeHelp@hq.doe.gov](mailto:ExchangeHelp@hq.doe.gov) (with FOA name and number in subject line).

responsibilities of each organization and (if applicable) previous collaborations among team members supporting the proposed project.

Submissions will not be evaluated against each other since they are not submitted in accordance with a common work statement. The above criteria will be weighted as follows:

Impact of the Proposed Technology Relative to FOA Targets	50%
Overall Scientific and Technical Merit	50%

## 2. CRITERIA FOR FULL APPLICATIONS

~~[TO BE INSERTED BY FOA MODIFICATION IN SEPTEMBER 2016]~~

Full Applications are evaluated based on the following criteria:

(1) *Impact of the Proposed Technology* (30%) - This criterion involves consideration of the following:

- The potential for a transformational and disruptive (not incremental) advancement in one or more energy-related fields;
- Thorough understanding of the current state-of-the-art and presentation of an innovative technical approach to significantly improve performance over the current state-of-the-art;
- Awareness of competing commercial and emerging technologies and identification of how the proposed concept/technology provides significant improvement over these other solutions; and
- A reasonable and effective strategy for transitioning the proposed technology from the laboratory to commercial deployment.

(2) *Overall Scientific and Technical Merit* (30%) - This criterion involves consideration of the following:

- The proposed work is unique and innovative;
- Clearly defined project outcomes and final deliverables;
- Substantiation that the proposed project is likely to meet or exceed the technical performance targets identified in this FOA;

Questions about this FOA? Check the Frequently Asked Questions available at <http://arpa-e.energy.gov/faq>. For questions that have not already been answered, email [ARPA-E-CO@hq.doe.gov](mailto:ARPA-E-CO@hq.doe.gov) (with FOA name and number in subject line); see FOA Sec. VII.A. Problems with ARPA-E eXCHANGE? Email [ExchangeHelp@hq.doe.gov](mailto:ExchangeHelp@hq.doe.gov) (with FOA name and number in subject line).



- Feasibility of the proposed work based upon preliminary data or other background information and sound scientific and engineering practices and principles;
- A sound technical approach, including appropriately defined technical tasks, to accomplish the proposed R&D objectives; and
- Management of risk, to include identifying major technical R&D risks and feasible, effective mitigation strategies.

(3) *Qualifications, Experience, and Capabilities of the Proposed Project Team* (30%) - This criterion involves consideration of the following:

- The PI and Project Team have the skill and expertise needed to successfully execute the project plan, evidenced by prior experience that demonstrates an ability to perform R&D of similar risk and complexity; and
- Access to the equipment and facilities necessary to accomplish the proposed R&D effort and/or a clear plan to obtain access to necessary equipment and facilities.

(4) *Soundness of Management Plan* (10%) - This criterion involves consideration of the following:

- Plausibility of plan to manage people and resources;
- Allocation of appropriate levels of effort and resources to proposed tasks;
- Reasonableness of the proposed project schedule, including major milestones; and
- Reasonableness of the proposed budget to accomplish the proposed project.

Submissions will not be evaluated against each other since they are not submitted in accordance with a common work statement.

### 3. CRITERIA FOR REPLIES TO REVIEWER COMMENTS

[TO BE INSERTED BY FOA MODIFICATION IN SEPTEMBER 2016]

ARPA-E has not established separate criteria to evaluate Replies to Reviewer Comments. Instead, Replies to Reviewer Comments are evaluated as an extension of the Full Application.

## **B. REVIEW AND SELECTION PROCESS**

### **1. PROGRAM POLICY FACTORS**

In addition to the above criteria, ARPA-E may consider the following program policy factors in determining which Concept Papers to encourage to submit a Full Application and which Full Applications to select for award negotiations:

- I. **ARPA-E Portfolio Balance.** Project balances ARPA-E portfolio in one or more of the following areas:
  - a. Diversity (including gender) of technical personnel in the proposed Project Team;
  - b. Technological diversity;
  - c. Organizational diversity;
  - d. Geographic diversity;
  - e. Technical or commercialization risk; or
  - f. Stage of technology development.
- II. **Relevance to ARPA-E Mission Advancement.** Project contributes to one or more of ARPA-E's key statutory goals:
  - a. Reduction of US dependence on foreign energy sources;
  - b. Stimulation of domestic manufacturing/**U.S. Manufacturing Plan**;
  - c. Reduction of energy-related emissions;
  - d. Increase in U.S. energy efficiency;
  - e. Enhancement of U.S. economic and energy security; or
  - f. Promotion of U.S. advanced energy technologies competitiveness.
- III. **Synergy of Public and Private Efforts.**
  - a. Avoids duplication and overlap with other publicly or privately funded projects;
  - b. Promotes increased coordination with nongovernmental entities for demonstration of technologies and research applications to facilitate technology transfer; or
  - c. Increases unique research collaborations.
- IV. **Low likelihood of other sources of funding.** High technical and/or financial uncertainty that results in the non-availability of other public, private or internal funding or resources to support the project.
- V. **High-Leveraging of Federal Funds.** Project leverages Federal funds to optimize advancement of programmatic goals by proposing cost share above the required minimum or otherwise accessing scarce or unique resources.
- VI. **High Project Impact Relative to Project Cost.**

Questions about this FOA? Check the Frequently Asked Questions available at <http://arpa-e.energy.gov/faq>. For questions that have not already been answered, email [ARPA-E-CO@hq.doe.gov](mailto:ARPA-E-CO@hq.doe.gov) (with FOA name and number in subject line); see FOA Sec. VII.A. Problems with ARPA-E eXCHANGE? Email [ExchangeHelp@hq.doe.gov](mailto:ExchangeHelp@hq.doe.gov) (with FOA name and number in subject line).

## 2. ARPA-E REVIEWERS

By submitting an application to ARPA-E, Applicants consent to ARPA-E's use of Federal employees, contractors, and experts from educational institutions, nonprofits, industry, and governmental and intergovernmental entities as reviewers. ARPA-E selects reviewers based on their knowledge and understanding of the relevant field and application, their experience and skills, and their ability to provide constructive feedback on applications.

ARPA-E requires all reviewers to complete a Conflict-of-Interest Certification and Nondisclosure Agreement through which they disclose their knowledge of any actual or apparent conflicts and agree to safeguard confidential information contained in Concept Papers, Full Applications, and Replies to Reviewer Comments. In addition, ARPA-E trains its reviewers in proper evaluation techniques and procedures.

Applicants are not permitted to nominate reviewers for their applications. Applicants may contact the Contracting Officer by email ([ARPA-E-CO@hq.doe.gov](mailto:ARPA-E-CO@hq.doe.gov)) if they have knowledge of a potential conflict of interest or a reasonable belief that a potential conflict exists.

## 3. ARPA-E SUPPORT CONTRACTOR

ARPA-E utilizes contractors to assist with the evaluation of applications and project management. To avoid actual and apparent conflicts of interest, ARPA-E prohibits its support contractors from submitting or participating in the preparation of applications to ARPA-E.

By submitting an application to ARPA-E, Applicants represent that they are not performing support contractor services for ARPA-E in any capacity and did not obtain the assistance of ARPA-E's support contractor to prepare the application. ARPA-E will not consider any applications that are submitted by or prepared with the assistance of its support contractors.

### C. ANTICIPATED ANNOUNCEMENT AND AWARD DATES

[TO BE INSERTED BY FOA MODIFICATION IN SEPTEMBER 2016]

ARPA-E expects to announce selections for negotiations in approximately January 2017 and to execute funding agreements in approximately June 2017.

## **VI. AWARD ADMINISTRATION INFORMATION**

### **A. AWARD NOTICES**

#### **1. REJECTED SUBMISSIONS**

Noncompliant and nonresponsive Concept Papers and Full Applications are rejected by the Contracting Officer and are not merit reviewed or considered for award. The Contracting Officer sends a notification letter by email to the technical and administrative points of contact designated by the Applicant in ARPA-E eXCHANGE. The notification letter states the basis upon which the Concept Paper or Full Application was rejected.

#### **2. CONCEPT PAPER NOTIFICATIONS**

ARPA-E promptly notifies Applicants of its determination to encourage or discourage the submission of a Full Application. ARPA-E sends a notification letter by email to the technical and administrative points of contact designated by the Applicant in ARPA-E eXCHANGE. ARPA-E provides feedback in the notification letter in order to guide further development of the proposed technology.

Applicants may submit a Full Application even if they receive a notification discouraging them from doing so. By discouraging the submission of a Full Application, ARPA-E intends to convey its lack of programmatic interest in the proposed project. Such assessments do not necessarily reflect judgments on the merits of the proposed project. The purpose of the Concept Paper phase is to save Applicants the considerable time and expense of preparing a Full Application that is unlikely to be selected for award negotiations.

A notification letter encouraging the submission of a Full Application does not authorize the Applicant to commence performance of the project. Please refer to Section IV.G.2 of the FOA for guidance on pre-award costs.

#### **3. FULL APPLICATION NOTIFICATIONS**

~~[TO BE INSERTED BY FOA MODIFICATION IN SEPTEMBER 2016]~~

ARPA-E promptly notifies Applicants of its determination. ARPA-E sends a notification letter by email to the technical and administrative points of contact designated by the Applicant in ARPA-E eXCHANGE. The notification letter may inform the Applicant that its Full Application was selected for award negotiations, or not selected. Alternatively, ARPA-E may notify one or more Applicants that a final selection determination on particular Full Applications will be made at a later date, subject to the availability of funds or other factors.

Questions about this FOA? Check the Frequently Asked Questions available at <http://arpa-e.energy.gov/faq>. For questions that have not already been answered, email [ARPA-E-CO@hq.doe.gov](mailto:ARPA-E-CO@hq.doe.gov) (with FOA name and number in subject line); see FOA Sec. VII.A. Problems with ARPA-E eXCHANGE? Email [ExchangeHelp@hq.doe.gov](mailto:ExchangeHelp@hq.doe.gov) (with FOA name and number in subject line).

Written feedback on Full Applications is made available to Applicants before the submission deadline for Replies to Reviewer Comments. By providing feedback, ARPA-E intends to guide the further development of the proposed technology and to provide a brief opportunity to respond to reviewer comments.

#### **a. SUCCESSFUL APPLICANTS**

ARPA-E has discretion to select all or part of a proposed project for negotiation of an award. A notification letter selecting a Full Application for award negotiations does not authorize the Applicant to commence performance of the project. **ARPA-E selects Full Applications for award negotiations, not for award.** Applicants do not receive an award until award negotiations are complete and the Contracting Officer executes the funding agreement. ARPA-E may terminate award negotiations at any time for any reason.

Please refer to Section IV.G.2 of the FOA for guidance on pre-award costs. Please also refer to the "Applicants' Guide to ARPA-E Award Negotiations" ([http://www.arpa-e.energy.gov/sites/default/files/documents/files/Award\\_Negotiations\\_Guide081613.pdf](http://www.arpa-e.energy.gov/sites/default/files/documents/files/Award_Negotiations_Guide081613.pdf)) for guidance on the award negotiation process.

#### **b. POSTPONED SELECTION DETERMINATIONS**

A notification letter postponing a final selection determination until a later date does not authorize the Applicant to commence performance of the project. ARPA-E may ultimately determine to select or not select the Full Application for award negotiations.

Please refer to Section IV.G.2 of the FOA for guidance on pre-award costs.

#### **c. UNSUCCESSFUL APPLICANTS**

By not selecting a Full Application, ARPA-E intends to convey its lack of programmatic interest in the proposed project. Such assessments do not necessarily reflect judgments on the merits of the proposed project. ARPA-E hopes that unsuccessful Applicants will submit innovative ideas and concepts for future FOAs.

### **B. ADMINISTRATIVE AND NATIONAL POLICY REQUIREMENTS**

[TO BE INSERTED BY FOA MODIFICATION IN SEPTEMBER 2016]

The following administrative and national policy requirements apply to Prime Recipients. The Prime Recipient is the responsible authority regarding the settlement and satisfaction of all contractual and administrative issues, including but not limited to disputes and claims arising out of any agreement between the Prime Recipient and a FFRDC contractor. Prime Recipients

Questions about this FOA? Check the Frequently Asked Questions available at <http://arpa-e.energy.gov/faq>. For questions that have not already been answered, email [ARPA-E-CO@hq.doe.gov](mailto:ARPA-E-CO@hq.doe.gov) (with FOA name and number in subject line); see FOA Sec. VII.A. Problems with ARPA-E eXCHANGE? Email [ExchangeHelp@hq.doe.gov](mailto:ExchangeHelp@hq.doe.gov) (with FOA name and number in subject line).

are required to flow down these requirements to their Subrecipients through subawards or related agreements.

## 1. DUNS NUMBER AND SAM, FSRS, AND FEDCONNECT REGISTRATIONS

Prime Recipients and Subrecipients are required to obtain a Dun and Bradstreet Data Universal Numbering System (DUNS) number at <http://fedgov.dnb.com/webform> and to register with the System for Award Management (SAM) at <https://www.sam.gov/portal/public/SAM/>.

Prime Recipients and Subrecipients should commence this process as soon as possible in order to expedite the execution of a funding agreement. Obtaining a DUNS number and registering with SAM could take several weeks.

Prime Recipients are also required to register with the Federal Funding Accountability and Transparency Act Subaward Reporting System (FSRS) at <https://www.fsrs.gov/>.<sup>17</sup> Prime Recipients are required to report to FSRS the names and total compensation of each of the Prime Recipient's five most highly compensated executives and the names and total compensation of each Subrecipient's five most highly compensated executives. Please refer to <https://www.fsrs.gov/> for guidance on reporting requirements.

ARPA-E may not execute a funding agreement with the Prime Recipient until it has obtained a DUNS number and completed its SAM and FSRS registrations. In addition, the Prime Recipient may not execute subawards with Subrecipients until they obtain a DUNS number and complete their SAM registration. Prime Recipients and Subrecipients are required to keep their SAM and FSRS data current throughout the duration of the project.

Finally, Prime Recipients are required to register with FedConnect in order to receive notification that their funding agreement has been executed by the Contracting Officer and to obtain a copy of the executed funding agreement. Please refer to <https://www.fedconnect.net/FedConnect/> for registration instructions.

## 2. NATIONAL POLICY ASSURANCES

Project Teams, including Prime Recipients and Subrecipients, are required to comply with the National Policy Assurances attached to their funding agreement in accordance with 2 C.F.R. 200.300. Please refer to Attachment 6 of ARPA-E's Model Cooperative Agreement (<http://arpa-e.energy.gov/FundingAgreements/CooperativeAgreements.aspx>) for information on the National Policy Assurances.

---

<sup>15</sup> The Federal Funding Accountability and Transparency Act, P.L. 109-282, 31 U.S.C. 6101 note.

### 3. PROOF OF COST SHARE COMMITMENT AND ALLOWABILITY

Upon selection for award negotiations, the Prime Recipient must confirm in writing that the proposed cost share contribution is allowable in accordance with applicable Federal cost principles.

The Prime Recipient is also required to provide cost share commitment letters from Subrecipients or third parties that are providing cost share, whether cash or in-kind. Each Subrecipient or third party that is contributing cost share must provide a letter on appropriate letterhead that is signed by an authorized corporate representative. Please refer to the “Applicants’ Guide to ARPA-E Award Negotiations” ([http://www.arpa-e.energy.gov/sites/default/files/documents/files/Award\\_Negotiations\\_Guide081613.pdf](http://www.arpa-e.energy.gov/sites/default/files/documents/files/Award_Negotiations_Guide081613.pdf)) for guidance on the contents of cost share commitment letters.

### 4. COST SHARE PAYMENTS<sup>18</sup>

All proposed cost share contributions must be reviewed in advance by the Contracting Officer and incorporated into the project budget before the expenditures are incurred.

The Prime Recipient is required to pay the “Cost Share” amount as a percentage of the total project costs in each invoice period for the duration of the period of performance. Small Businesses see Section III.B.3 of the FOA.

Please refer to the “Applicants’ Guide to ARPA-E Award Negotiations” ([http://www.arpa-e.energy.gov/sites/default/files/documents/files/Award\\_Negotiations\\_Guide081613.pdf](http://www.arpa-e.energy.gov/sites/default/files/documents/files/Award_Negotiations_Guide081613.pdf)) for additional guidance on cost share payment requirements.

ARPA-E may deny reimbursement requests, in whole or in part, or modify or terminate funding agreements where Prime Recipients (or Project Teams) fail to comply with ARPA-E’s cost share payment requirements.

### 5. ENVIRONMENTAL IMPACT QUESTIONNAIRE

By law, ARPA-E is required to evaluate the potential environmental impact of projects that it is considering for funding. In particular, ARPA-E must determine before funding a project whether the project qualifies for a categorical exclusion under 10 C.F.R. § 1021.410 or whether it requires further environmental review (i.e., an environmental assessment or an environmental impact statement).

To facilitate and expedite ARPA-E’s environmental review, Prime Recipients are required to complete an Environmental Impact Questionnaire during award negotiations. This form is

<sup>16</sup> Please refer to Section III.B of the FOA for guidance on cost share requirements.

Questions about this FOA? Check the Frequently Asked Questions available at <http://arpa-e.energy.gov/faq>. For questions that have not already been answered, email [ARPA-E-CO@hq.doe.gov](mailto:ARPA-E-CO@hq.doe.gov) (with FOA name and number in subject line); see FOA Sec. VII.A. Problems with ARPA-E eXCHANGE? Email [ExchangeHelp@hq.doe.gov](mailto:ExchangeHelp@hq.doe.gov) (with FOA name and number in subject line).

available on ARPA-E eXCHANGE at <https://arpa-e-foa.energy.gov>. The Environmental Impact Questionnaire is due within 21 calendar days of the selection announcement.

## 6. TECHNOLOGY-TO-MARKET PLAN

During award negotiations, Prime Recipients are required to negotiate and submit an initial Technology-to-Market Plan to the ARPA-E Program Director, and obtain the ARPA-E Program Director's approval prior to the execution of the award. Prime Recipients must show how budgeted Technology Transfer and Outreach (TT&O) costs relate to furthering elements of the Technology-to-Market Plan. During the period of performance, Prime Recipients are required to provide regular updates on the initial Technology-to-Market plan and report on implementation of Technology-to-Market activities. Prime Recipients may be required to perform other actions to further the commercialization of their respective technologies.

ARPA-E may waive or modify this requirement, as appropriate.

## 7. INTELLECTUAL PROPERTY AND DATA MANAGEMENT PLANS

ARPA-E requires every Project Team to negotiate and establish an Intellectual Property Management Plan for the management and disposition of intellectual property arising from the project. The Prime Recipient must submit a completed and signed Intellectual Property Management plan to ARPA-E within six weeks of the effective date of the ARPA-E funding agreement. All Intellectual Property Management Plans are subject to the terms and conditions of the ARPA-E funding agreement and its intellectual property provisions, and applicable Federal laws, regulations, and policies, all of which take precedence over the terms of Intellectual Property Management Plans.

ARPA-E has developed a template for Intellectual Property Management Plans (<http://arpa-e.energy.gov/FundingAgreements/Overview.aspx>) so as to facilitate and expedite negotiations between Project Team members. ARPA-E does not mandate the use of this template. ARPA-E and DOE do not make any warranty (express or implied) or assume any liability or responsibility for the accuracy, completeness, or usefulness of the template. ARPA-E and DOE strongly encourage Project Teams to consult independent legal counsel before using the template.

Awardees are also required, post-award, to submit a Data Management Plan (DMP) that addresses how data generated in the course of the work performed under an ARPA-E award will be preserved and, as appropriate, shared publicly. The Prime Recipient must submit a completed and signed DMP - as part of the Team's Intellectual Property Management Plan - to ARPA-E within six weeks of the effective date of the ARPA-E funding agreement. The DMP must meet the minimum requirements set forth in ARPA-E's "Applicant Guide to Award Negotiations" available at the following website: <http://arpa-e.energy.gov/?q=arpa-e-site-page/pre-award-guidance>.

Questions about this FOA? Check the Frequently Asked Questions available at <http://arpa-e.energy.gov/faq>. For questions that have not already been answered, email [ARPA-E-CO@hq.doe.gov](mailto:ARPA-E-CO@hq.doe.gov) (with FOA name and number in subject line); see FOA Sec. VII.A. Problems with ARPA-E eXCHANGE? Email [ExchangeHelp@hq.doe.gov](mailto:ExchangeHelp@hq.doe.gov) (with FOA name and number in subject line).



## **8. U.S. MANUFACTURING REQUIREMENT**

In addition to treatment of the U.S. Manufacturing Plan described above in Section IV.D.7 of the FOA, ARPA-E requires products embodying or produced through the use of subject inventions (i.e., inventions conceived or first actually reduced to practice under ARPA-E funding agreements) to be substantially manufactured in the United States by Project Teams and their licensees, as described below. The Applicant may request a modification or waiver of the U.S. Manufacturing Requirement.

### ***a. SMALL BUSINESSES***

Small businesses (including Small Business Concerns) that are Prime Recipients or Subrecipients under ARPA-E funding agreements are required to substantially manufacture the following products in the United States for any use or sale in the United States: (1) products embodying subject inventions, and (2) products produced through the use of subject invention(s).<sup>19</sup> This requirement does not apply to products that are manufactured for use or sale outside the U.S. A.

Small businesses must apply the same U.S. Manufacturing requirements to their assignees, licensees, and entities acquiring a controlling interest in the small business. Small businesses must require their assignees and entities acquiring a controlling interest in the small business to apply the same U.S. Manufacturing requirements to their licensees.

### ***b. LARGE BUSINESSES AND FOREIGN ENTITIES***

Large businesses and foreign entities that are Prime Recipients or Subrecipients under ARPA-E funding agreements are required to substantially manufacture the following products in the United States: (1) products embodying subject inventions, and (2) products produced through the use of subject invention(s).<sup>20</sup> This requirement applies to products that are manufactured for use or sale in the United States and outside the United States.

Large businesses and foreign entities must apply the same U.S. Manufacturing requirements to their assignees, licensees, and entities acquiring a controlling interest in the large business or foreign entity. Large businesses and foreign entities must require their assignees and entities

---

<sup>19</sup> Small businesses are generally defined as domestically incorporated entities that meet the criteria established by the U.S. Small Business Administration's "Table of Small Business Size Standards Matched to North American Industry Classification System Codes" (<http://www.sba.gov/content/small-business-size-standards>).

<sup>20</sup> Large businesses are generally defined as domestically incorporated entities that do not meet the criteria established by the U.S. Small Business Administration's "Table of Small Business Size Standards Matched to North American Industry Classification System Codes" (<http://www.sba.gov/content/small-business-size-standards>).

acquiring a controlling interest in the large business or foreign entity to apply the same U.S. Manufacturing requirements to their licensees.

### ***c. EDUCATIONAL INSTITUTIONS AND NONPROFITS***

Domestic educational institutions and nonprofits that are Prime Recipients or Subrecipients under ARPA-E funding agreements must require their exclusive licensees to substantially manufacture the following products in the United States for any use or sale in the United States: (1) articles embodying subject inventions, and (2) articles produced through the use of subject invention(s). This requirement does not apply to articles that are manufactured for use or sale overseas.

Educational institutions and nonprofits must require their assignees to apply the same U.S. Manufacturing requirements to their exclusive licensees.

These U.S. Manufacturing requirements do not apply to nonexclusive licensees.

### ***d. FFRDCs/DOE Labs and State and Local Government Entities***

FFRDCs/DOE Labs that are GOCOs and state and local government entities are subject to the same U.S. Manufacturing requirements as domestic educational institutions and nonprofits. GOGOs are subject to the requirements in 37 CFR § 404.5(a)(2).

## **9. CORPORATE FELONY CONVICTIONS AND FEDERAL TAX LIABILITY**

In submitting an application in response to this FOA, the Applicant represents that:

- It is not a corporation that has been convicted of a felony criminal violation under any Federal law within the preceding 24 months; and
- It is not a corporation that has any unpaid Federal tax liability that has been assessed, for which all judicial and administrative remedies have been exhausted or have lapsed, and that is not being paid in a timely manner pursuant to an agreement with the authority responsible for collecting the tax liability.

For purposes of these representations the following definitions apply: A Corporation includes any entity that has filed articles of incorporation in any of the 50 states, the District of Columbia, or the various territories of the United States [but not foreign corporations]. It includes both for-profit and non-profit organizations.

Questions about this FOA? Check the Frequently Asked Questions available at <http://arpa-e.energy.gov/faq>. For questions that have not already been answered, email [ARPA-E-CO@hq.doe.gov](mailto:ARPA-E-CO@hq.doe.gov) (with FOA name and number in subject line); see FOA Sec. VII.A. Problems with ARPA-E eXCHANGE? Email [ExchangeHelp@hq.doe.gov](mailto:ExchangeHelp@hq.doe.gov) (with FOA name and number in subject line).

## 10. APPLICANT RISK ANALYSIS

If selected for award negotiations, ARPA-E may evaluate the risks posed by the Applicant using the criteria set forth at 2 CFR §200.205(c), subparagraphs (1) through (4). ARPA-E may require special award terms and conditions depending upon results of the risk analysis.

## 11. RECIPIENT INTEGRITY AND PERFORMANCE MATTERS

Prior to making a Federal award with a total amount of Federal share greater than the simplified acquisition threshold (presently \$150,000), ARPA-E is required to review and consider any information about Applicants that is contained in the Office of Management and Budget's designated integrity and performance system accessible through SAM (currently the Federal Awardee Performance and Integrity Information System or FAPIIS) (41 U.S.C. § 2313 and 2 C.F.R. 200.205).

Applicants may review information in FAPIIS and comment on any information about itself that a Federal awarding agency previously entered into FAPIIS.

ARPA-E will consider any written comments provided by Applicants during award negotiations, in addition to the other information in FAPIIS, in making a judgment about an Applicant's integrity, business ethics, and record of performance under Federal awards when reviewing potential risk posed by Applicants as described in 2 C.F.R. §200.205.

## 12. NONDISCLOSURE AND CONFIDENTIALITY AGREEMENTS REPRESENTATIONS

In submitting an application in response to this FOA the Applicant represents that:

- (1) **It does not and will not** require its employees or contractors to sign internal nondisclosure or confidentiality agreements or statements prohibiting or otherwise restricting its employees or contractors from lawfully reporting waste, fraud, or abuse to a designated investigative or law enforcement representative of a Federal department or agency authorized to receive such information.
- (2) **It does not and will not** use any Federal funds to implement or enforce any nondisclosure and/or confidentiality policy, form, or agreement it uses unless it contains the following provisions:
  - a. *“These provisions are consistent with and do not supersede, conflict with, or otherwise alter the employee obligations, rights, or liabilities created by existing statute or Executive order relating to (1) classified information, (2) communications to Congress, (3) the reporting to an Inspector General of a violation of any law, rule, or regulation, or mismanagement, a gross waste of funds, an abuse of authority, or a*

Questions about this FOA? Check the Frequently Asked Questions available at <http://arpa-e.energy.gov/faq>. For questions that have not already been answered, email [ARPA-E-CO@hq.doe.gov](mailto:ARPA-E-CO@hq.doe.gov) (with FOA name and number in subject line); see FOA Sec. VII.A. Problems with ARPA-E eXCHANGE? Email [ExchangeHelp@hq.doe.gov](mailto:ExchangeHelp@hq.doe.gov) (with FOA name and number in subject line).

*substantial and specific danger to public health or safety, or (4) any other whistleblower protection. The definitions, requirements, obligations, rights, sanctions, and liabilities created by controlling Executive orders and statutory provisions are incorporated into this agreement and are controlling.”*

- b. The limitation above shall not contravene requirements applicable to Standard Form 312, Form 4414, or any other form issued by a Federal department or agency governing the nondisclosure of classified information.
- c. Notwithstanding provision listed in paragraph (a), a nondisclosure confidentiality policy form or agreement that is to be executed by a person connected with the conduct of an intelligence or intelligence-related activity, other than an employee or officer of the United States Government, may contain provisions appropriate to the particular activity for which such document is to be used. Such form or agreement shall, at a minimum, require that the person will not disclose any classified information received in the course of such activity unless specifically authorized to do so by the United States Government. Such nondisclosure or confidentiality forms shall also make it clear that they do not bar disclosure to congress, or to an authorized official of an executive agency or the Department of Justice, that are essential to reporting a substantial violation of law.

### **C. REPORTING**

[TO BE INSERTED BY FOA MODIFICATION IN SEPTEMBER 2016]

Recipients are required to submit periodic, detailed reports on technical, financial, and other aspects of the project, as described in Attachment 4 to ARPA-E’s Model Cooperative Agreement (<http://arpa-e.energy.gov/arpa-e-site-page/award-guidance>).

## **VII. AGENCY CONTACTS**

### **A. COMMUNICATIONS WITH ARPA-E**

Upon the issuance of a FOA, only the Contracting Officer may communicate with Applicants. ARPA-E personnel and our support contractors are prohibited from communicating (in writing or otherwise) with Applicants regarding the FOA. This “quiet period” remains in effect until ARPA-E’s public announcement of its project selections.

During the “quiet period,” Applicants are required to submit all questions regarding this FOA to [ARPA-E-CO@hq.doe.gov](mailto:ARPA-E-CO@hq.doe.gov). Questions and Answers (Q&As) about ARPA-E and the FOA are available at <http://arpa-e.energy.gov/faq>. For questions that have not already been answered,

Questions about this FOA? Check the Frequently Asked Questions available at <http://arpa-e.energy.gov/faq>. For questions that have not already been answered, email [ARPA-E-CO@hq.doe.gov](mailto:ARPA-E-CO@hq.doe.gov) (with FOA name and number in subject line); see FOA Sec. VII.A. Problems with ARPA-E eXCHANGE? Email [ExchangeHelp@hq.doe.gov](mailto:ExchangeHelp@hq.doe.gov) (with FOA name and number in subject line).

please send an email with the FOA name and number in the subject line to [ARPA-E-CO@hq.doe.gov](mailto:ARPA-E-CO@hq.doe.gov). Due to the volume of questions received, ARPA-E will only answer pertinent questions that have not yet been answered and posted at the above link.

- ARPA-E will post responses on a weekly basis to any questions that are received. ARPA-E may re-phrase questions or consolidate similar questions for administrative purposes.
- ARPA-E will cease to accept questions approximately 5 business days in advance of each submission deadline. Responses to questions received before the cutoff will be posted approximately one business day in advance of the submission deadline. ARPA-E may re-phrase questions or consolidate similar questions for administrative purposes.
- Responses are posted to “Questions and Answers” on ARPA-E’s website (<http://arpa-e.energy.gov/faq>).

Applicants may submit questions regarding ARPA-E eXCHANGE, ARPA-E’s online application portal, to [ExchangeHelp@hq.doe.gov](mailto:ExchangeHelp@hq.doe.gov). ARPA-E will promptly respond to emails that raise legitimate, technical issues with ARPA-E eXCHANGE. ARPA-E will refer any questions regarding the FOA to [ARPA-E-CO@hq.doe.gov](mailto:ARPA-E-CO@hq.doe.gov).

ARPA-E will not accept or respond to communications received by other means (e.g., fax, telephone, mail, hand delivery). Emails sent to other email addresses will be disregarded.

During the “quiet period,” only the Contracting Officer may authorize communications between ARPA-E personnel and Applicants. The Contracting Officer may communicate with Applicants as necessary and appropriate. As described in Section IV.A of the FOA, the Contracting Officer may arrange pre-selection meetings and/or site visits during the “quiet period.”

## **B. DEBRIEFINGS**

ARPA-E does not offer or provide debriefings. ARPA-E provides Applicants with a notification encouraging or discouraging the submission of a Full Application based on ARPA-E’s assessment of the Concept Paper. In addition, ARPA-E provides Applicants with reviewer comments on Full Applications before the submission deadline for Replies to Reviewer Comments.

Questions about this FOA? Check the Frequently Asked Questions available at <http://arpa-e.energy.gov/faq>. For questions that have not already been answered, email [ARPA-E-CO@hq.doe.gov](mailto:ARPA-E-CO@hq.doe.gov) (with FOA name and number in subject line); see FOA Sec. VII.A. Problems with ARPA-E eXCHANGE? Email [ExchangeHelp@hq.doe.gov](mailto:ExchangeHelp@hq.doe.gov) (with FOA name and number in subject line).

## **VIII. OTHER INFORMATION**

### **A. FOAs AND FOA MODIFICATIONS**

FOAs are posted on ARPA-E eXCHANGE (<https://arpa-e-foa.energy.gov/>), Grants.gov (<http://www.grants.gov/>), and FedConnect (<https://www.fedconnect.net/FedConnect/>). Any modifications to the FOA are also posted to these websites. You can receive an e-mail when a modification is posted by registering with FedConnect as an interested party for this FOA. It is recommended that you register as soon as possible after release of the FOA to ensure that you receive timely notice of any modifications or other announcements. More information is available at <https://www.fedconnect.net>.

### **B. OBLIGATION OF PUBLIC FUNDS**

The Contracting Officer is the only individual who can make awards on behalf of ARPA-E or obligate ARPA-E to the expenditure of public funds. A commitment or obligation by any individual other than the Contracting Officer, either explicit or implied, is invalid.

ARPA-E awards may not be transferred, assigned, or assumed without the prior written consent of a Contracting Officer.

### **C. REQUIREMENT FOR FULL AND COMPLETE DISCLOSURE**

Applicants are required to make a full and complete disclosure of the information requested in the Business Assurances & Disclosures Form. Disclosure of the requested information is mandatory. Any failure to make a full and complete disclosure of the requested information may result in:

- The rejection of a Concept Paper, Full Application, and/or Reply to Reviewer Comments;
- The termination of award negotiations;
- The modification, suspension, and/or termination of a funding agreement;
- The initiation of debarment proceedings, debarment, and/or a declaration of ineligibility for receipt of Federal contracts, subcontracts, and financial assistance and benefits; and
- Civil and/or criminal penalties.

Questions about this FOA? Check the Frequently Asked Questions available at <http://arpa-e.energy.gov/faq>. For questions that have not already been answered, email [ARPA-E-CO@hq.doe.gov](mailto:ARPA-E-CO@hq.doe.gov) (with FOA name and number in subject line); see FOA Sec. VII.A. Problems with ARPA-E eXCHANGE? Email [ExchangeHelp@hq.doe.gov](mailto:ExchangeHelp@hq.doe.gov) (with FOA name and number in subject line).

**D. RETENTION OF SUBMISSIONS**

ARPA-E expects to retain copies of all Concept Papers, Full Applications, Replies to Reviewer Comments, and other submissions. No submissions will be returned. By applying to ARPA-E for funding, Applicants consent to ARPA-E's retention of their submissions.

**E. MARKING OF CONFIDENTIAL INFORMATION**

ARPA-E will use data and other information contained in Concept Papers, Full Applications, and Replies to Reviewer Comments strictly for evaluation purposes.

Concept Papers, Full Applications, Replies to Reviewer Comments, and other submissions containing confidential, proprietary, or privileged information must be marked as described below. Failure to comply with these marking requirements may result in the disclosure of the unmarked information under the Freedom of Information Act or otherwise. The U.S. Government is not liable for the disclosure or use of unmarked information, and may use or disclose such information for any purpose.

The cover sheet of the Concept Paper, Full Application, Reply to Reviewer Comments, or other submission must be marked as follows and identify the specific pages containing confidential, proprietary, or privileged information:

Notice of Restriction on Disclosure and Use of Data:

Pages [\_\_\_] of this document may contain confidential, proprietary, or privileged information that is exempt from public disclosure. Such information shall be used or disclosed only for evaluation purposes or in accordance with a financial assistance or loan agreement between the submitter and the Government. The Government may use or disclose any information that is not appropriately marked or otherwise restricted, regardless of source.

The header and footer of every page that contains confidential, proprietary, or privileged information must be marked as follows: "Contains Confidential, Proprietary, or Privileged Information Exempt from Public Disclosure." In addition, every line and paragraph containing proprietary, privileged, or trade secret information must be clearly marked with double brackets or highlighting.

**F. TITLE TO SUBJECT INVENTIONS**

Ownership of subject inventions is governed pursuant to the authorities listed below. Typically, either by operation of law or under the authority of a patent waiver, Prime Recipients and Subrecipients may elect to retain title to their subject inventions under ARPA-E funding agreements.

Questions about this FOA? Check the Frequently Asked Questions available at <http://arpa-e.energy.gov/faq>. For questions that have not already been answered, email [ARPA-E-CO@hq.doe.gov](mailto:ARPA-E-CO@hq.doe.gov) (with FOA name and number in subject line); see FOA Sec. VII.A. Problems with ARPA-E eXCHANGE? Email [ExchangeHelp@hq.doe.gov](mailto:ExchangeHelp@hq.doe.gov) (with FOA name and number in subject line).

- Domestic Small Businesses, Educational Institutions, and Nonprofits: Under the Bayh-Dole Act (35 U.S.C. § 200 et seq.), domestic small businesses, educational institutions, and nonprofits may elect to retain title to their subject inventions. If they elect to retain title, they must file a patent application in a timely fashion.
- All other parties: The Federal Non-Nuclear Energy Act of 1974, 42 U.S.C. 5908, provides that the Government obtains title to new inventions unless a waiver is granted (*see below*).
- Class Waiver: Under 42 U.S.C. § 5908, title to subject inventions vests in the U.S. Government and large businesses and foreign entities do not have the automatic right to elect to retain title to subject inventions. However, ARPA-E typically issues “class patent waivers” under which large businesses and foreign entities that meet certain stated requirements, such as cost sharing of at least 20% may elect to retain title to their subject inventions. If a large business or foreign entity elects to retain title to its subject invention, it must file a patent application in a timely fashion. If the class waiver does not apply, a party may request a waiver in accordance with 10 C.F.R. §784.
- GOGOs are subject to the requirements of 37 CFR Part 501.
- Determination of Exceptional Circumstances (DEC): Each Applicant is required to submit a U.S. Manufacturing Plan as part of its Full Application. The U.S. manufacture provision included in Attachment 2 of an award is included as part of the U.S. Manufacturing Plan. If selected, the U.S. Manufacturing Plan may be incorporated into the award terms and conditions for domestic small businesses and nonprofit organizations. DOE has determined that exceptional circumstances exist that warrants the modification of the standard patent rights clause for small businesses and non-profit awardees under Bayh-Dole to the extent necessary to implement and enforce the U.S. Manufacturing Plan. For example, the commitments and enforcement of a U.S. Manufacturing Plan may be tied to subject inventions. Any Bayh-Dole entity (domestic small business or nonprofit organization) affected by this DEC has the right to appeal it. The DEC is dated September 9, 2013 and is available at the following link: <http://energy.gov/gc/downloads/determination-exceptional-circumstances-under-bayh-dole-act-energy-efficiency-renewable>.

## **G. GOVERNMENT RIGHTS IN SUBJECT INVENTIONS**

Where Prime Recipients and Subrecipients retain title to subject inventions, the U.S. Government retains certain rights.

Questions about this FOA? Check the Frequently Asked Questions available at <http://arpa-e.energy.gov/faq>. For questions that have not already been answered, email [ARPA-E-CO@hq.doe.gov](mailto:ARPA-E-CO@hq.doe.gov) (with FOA name and number in subject line); see FOA Sec. VII.A. Problems with ARPA-E eXCHANGE? Email [ExchangeHelp@hq.doe.gov](mailto:ExchangeHelp@hq.doe.gov) (with FOA name and number in subject line).



## 1. GOVERNMENT USE LICENSE

The U.S. Government retains a nonexclusive, nontransferable, irrevocable, paid-up license to practice or have practiced for or on behalf of the United States any subject invention throughout the world. This license extends to contractors doing work on behalf of the Government.

## 2. MARCH-IN RIGHTS

The U.S. Government retains march-in rights with respect to all subject inventions. Through “march-in rights,” the Government may require a Prime Recipient or Subrecipient who has elected to retain title to a subject invention (or their assignees or exclusive licensees), to grant a license for use of the invention. In addition, the Government may grant licenses for use of the subject invention when Prime Recipients, Subrecipients, or their assignees and exclusive licensees refuse to do so.

The U.S. Government may exercise its march-in rights if it determines that such action is necessary under any of the four following conditions:

- The owner or licensee has not taken or is not expected to take effective steps to achieve practical application of the invention within a reasonable time;
- The owner or licensee has not taken action to alleviate health or safety needs in a reasonably satisfactory manner;
- The owner has not met public use requirements specified by Federal statutes in a reasonably satisfactory manner; or
- The U.S. Manufacturing requirement has not been met.

## 3. U.S. MANUFACTURING REQUIREMENT

ARPA-E requires that awards address whether products embodying or produced through the use of subject inventions (i.e., inventions conceived or first actually reduced to practice under ARPA-E funding agreements) are to be substantially manufactured in the United States by Project Teams and their licensees. The requirement varies depending upon whether an awardee is a small business, University or other type of awardee. The Applicant may request a modification or waiver of the U.S. Manufacturing Requirement.

## H. RIGHTS IN TECHNICAL DATA

Data rights differ based on whether data is first produced under an award or instead was developed at private expense outside the award.

Questions about this FOA? Check the Frequently Asked Questions available at <http://arpa-e.energy.gov/faq>. For questions that have not already been answered, email [ARPA-E-CO@hq.doe.gov](mailto:ARPA-E-CO@hq.doe.gov) (with FOA name and number in subject line); see FOA Sec. VII.A. Problems with ARPA-E eXCHANGE? Email [ExchangeHelp@hq.doe.gov](mailto:ExchangeHelp@hq.doe.gov) (with FOA name and number in subject line).

- Background or “Limited Rights Data”: The U.S. Government will not normally require delivery of technical data developed solely at private expense prior to issuance of an award, except as necessary to monitor technical progress and evaluate the potential of proposed technologies to reach specific technical and cost metrics.
- Generated Data: The U.S. Government normally retains very broad rights in technical data produced under Government financial assistance awards, including the right to distribute to the public. However, pursuant to special statutory authority, certain categories of data generated under ARPA-E awards may be protected from public disclosure for up to five years in accordance with provisions that will be set forth in the award. In addition, invention disclosures may be protected from public disclosure for a reasonable time in order to allow for filing a patent application.

## I. PROTECTED PERSONALLY IDENTIFIABLE INFORMATION

Applicants may not include any Protected Personally Identifiable Information (Protected PII) in their submissions to ARPA-E. Protected PII is defined as data that, if compromised, could cause harm to an individual such as identity theft. Listed below are examples of Protected PII that Applicants must not include in their submissions.

- Social Security Numbers in any form;
- Place of Birth associated with an individual;
- Date of Birth associated with an individual;
- Mother’s maiden name associated with an individual;
- Biometric record associated with an individual;
- Fingerprint;
- Iris scan;
- DNA;
- Medical history information associated with an individual;
- Medical conditions, including history of disease;
- Metric information, e.g. weight, height, blood pressure;
- Criminal history associated with an individual;
- Ratings;
- Disciplinary actions;
- Performance elements and standards (or work expectations) are PII when they are so intertwined with performance appraisals that their disclosure would reveal an individual’s performance appraisal;
- Financial information associated with an individual;
- Credit card numbers;
- Bank account numbers; and
- Security clearance history or related information (not including actual clearances held).

Questions about this FOA? Check the Frequently Asked Questions available at <http://arpa-e.energy.gov/faq>. For questions that have not already been answered, email [ARPA-E-CO@hq.doe.gov](mailto:ARPA-E-CO@hq.doe.gov) (with FOA name and number in subject line); see FOA Sec. VII.A. Problems with ARPA-E eXCHANGE? Email [ExchangeHelp@hq.doe.gov](mailto:ExchangeHelp@hq.doe.gov) (with FOA name and number in subject line).

## J. COMPLIANCE AUDIT REQUIREMENT

A prime recipient organized as a for-profit entity expending \$750,000 or more of DOE funds in the entity's fiscal year (including funds expended as a Subrecipient) must have an annual compliance audit performed at the completion of its fiscal year. For additional information, refer to Subpart F of: (i) 2 C.F.R. Part 200, and (ii) 2 C.F.R. Part 910.

If an educational institution, non-profit organization, or state/local government is either a Prime Recipient or a Subrecipient, and has expended \$750,000 or more of Federal funds in the entity's fiscal year, the entity must have an annual compliance audit performed at the completion of its fiscal year. For additional information refer to Subpart F of 2 C.F.R. Part 200.

## IX. REFERENCES

- [1] J. G. Koomey, "Growth in data center electricity use 2005 to 2010", A report by Analytics Press, completed at the request of The New York Times. <http://www.analyticspress.com/datacenters.html>
- [2] J. G. Koomey, "Worldwide electricity used in data centers", Environ. Res. Lett. 3 (2008) 034008 (8pp), doi:10.1088/1748-9326/3/3/034008
- [3] W. Van Heddeghem, "Trends in worldwide ICT electricity consumption from 2007 to 2012", Computer Communications 50 (2014) 64-76.
- [4] NRDC, Anthesis, "Data Center Efficiency Assessment", AUGUST 2014 IP:14-08-A.
- [5] K. Balil, "Green Data Centers Networks: Challenges and Opportunities", Frontiers of Information Technology (FIT), 2013 International Conference on, DOI:10.1109/FIT.2013.49
- [6] <http://www.statista.com/statistics/201794/us-electricity-consumption-since-1975/>
- [7] U.S. Energy Information Administration (eia), <https://www.eia.gov/cfapps/ipdbproject/iedindex3.cfm?tid=2&pid=2&aid=2&cid=regions&syid=2000&eyid=2012&unit=BKWH>
- [8] D. Abts et al., "Energy Proportional datacenters Networks", ISCA'10, June 19-23, 2010 Saint-Malo, France.
- [9] O. Zik, A. Shapiro, "Coal Computing: How Companies Misunderstand Their Dirty Data Centers". February 2016, Lux Research White Paper.

Questions about this FOA? Check the Frequently Asked Questions available at <http://arpa-e.energy.gov/faq>. For questions that have not already been answered, email [ARPA-E-CO@hq.doe.gov](mailto:ARPA-E-CO@hq.doe.gov) (with FOA name and number in subject line); see FOA Sec. VII.A. Problems with ARPA-E eXCHANGE? Email [ExchangeHelp@hq.doe.gov](mailto:ExchangeHelp@hq.doe.gov) (with FOA name and number in subject line).

[10] <http://opencompute.org/>

[11] <http://cobo.azurewebsites.net/>

[12] Binkert, Schreiber, Ho Ahn, et al. "The Role of Optics in Future High Radix Switch Design". ISCA 2011, San Jose, CA.

[13] Abts, Liu, et al. "Energy Proportional Data Center Networks". ISCA 2010, Saint-Malo, France.

[14] Miller, D.: Device requirements for optical interconnects to silicon chips. Vol. 97, 1166-1185, No. 7, July 2009 | Proceedings of the IEEE. Proc. IEEE 97

[15] N. Binkert, et al., "Optical high radix switch design", IEEE Micro May 2012, DOI: 10.1109/MM.2012.24

[16] Broadcom presentation at OFC 2016.

[17] Cisco, Cisco Global Cloud Index, 2013-2018, November 2014.

[18] OFC 2016 Conference Proceedings.

[19] "Vision and Roadmap: Routing Telecom and Data Centers Toward Efficient Energy Use". Joint DOE and Industry Workshop, Sunnyvale, CA. Report published May 13, 2009.

[20] "Is 25 Gb/s On board Signaling Viable?", Dong Kam et al., IEEE Transactions on advanced packaging, Vol. 32, No. 2, May 2009

[21] United States Data Center Energy Usage Report, Arman Shehabi *et al.* June 2016, LBNL-1005775.

## **X. GLOSSARY**

**b:** bit

**B:** Byte = 8 bits

**b/s:** bits/second

**Tb/s:**  $10^{12}$  bits/second

**Bandwidth density:** the amount of bits/second per unit length along the perimeter edge of an electrical processor chip, such as a CPU or memory chip, subject to practical constraints of size and design that is embedded on a server board

Questions about this FOA? Check the Frequently Asked Questions available at <http://arpa-e.energy.gov/faq>. For questions that have not already been answered, email [ARPA-E-CO@hq.doe.gov](mailto:ARPA-E-CO@hq.doe.gov) (with FOA name and number in subject line); see FOA Sec. VII.A. Problems with ARPA-E eXCHANGE? Email [ExchangeHelp@hq.doe.gov](mailto:ExchangeHelp@hq.doe.gov) (with FOA name and number in subject line).

**Applicant:** The entity that submits the application to ARPA-E. In the case of a Project Team, the Applicant is the lead organization listed on the application.

**Application:** The entire submission received by ARPA-E, including the Concept Paper, Full Application, and Reply to Reviewer Comments.

**ARPA-E:** is the Advanced Research Projects Agency – Energy, an agency within the U.S. Department of Energy.

**Cost Sharing:** is the portion of project costs from non-Federal sources that are borne by the Prime Recipient (or non-Federal third parties on behalf of the Prime Recipient), rather than by the Federal Government.

**Deliverable:** A deliverable is the quantifiable goods or services that will be provided upon the successful completion of a project task or sub-task.

**DOE:** U.S. Department of Energy.

**DOE/NNSA:** U.S. Department of Energy/National Nuclear Security Administration

**Electrical interconnect:** all associated circuitry and components needed to send data between electrical processor or memory chips

**FFRDCs:** Federally Funded Research and Development Centers.

**FOA:** Funding Opportunity Announcement.

**FLOPs:** Floating Point Operations per second

**GOCOs:** U.S. Government Owned, Contractor Operated laboratories.

**GOGOs:** U.S. Government Owned, Government Operated laboratories.

**Interconnect:** data link between devices

**ITRS:** International Technology Roadmap for Semiconductors

**Long Reach:** Over 1 km

**Milestone:** A milestone is the tangible, observable measurement that will be provided upon the successful completion of a project task or sub-task.

Questions about this FOA? Check the Frequently Asked Questions available at <http://arpa-e.energy.gov/faq>. For questions that have not already been answered, email [ARPA-E-CO@hq.doe.gov](mailto:ARPA-E-CO@hq.doe.gov) (with FOA name and number in subject line); see FOA Sec. VII.A. Problems with ARPA-E eXCHANGE? Email [ExchangeHelp@hq.doe.gov](mailto:ExchangeHelp@hq.doe.gov) (with FOA name and number in subject line).

**Network:** All of the IT infrastructure required to move data in a datacenter, aside from electronic processor and memory chips in servers

**Network architecture:** the topology of connections between switches and servers and their interconnects in datacenters

**North-South and East-West communications:** Data communications at the level of the TOR and above is commonly referred to as “east-west” and from the TOR to the processor and memory chips within server boards as “north-south”.

**OE / EO:** optical to electrical data conversion / electrical to optical data conversion

**Prime Recipient:** The signatory to the funding agreement with ARPA-E.

**PI:** Principal Investigator.

**Project Team:** A Project Team consists of the Prime Recipient, Subrecipients, and others performing inventive supportive work that is part of an ARPA-E project.

**Radix:** the number of ports in a switch, for example if a switch has an aggregate bandwidth of 1 Tb/s and a radix (in other words , port count) of 10, that means that the switch has 10 ports at 100 Gb/s each, or a radix = 10 with 100 Gb/s per port.

**Silicon Photonics:** study and application of photonic systems which use silicon as an optical medium

**Single mode fiber:** is optical fiber that is designed for the transmission of a single ray or mode of light as a carrier

**Standalone Applicant:** An Applicant that applies for funding on its own, not as part of a Project Team.

**Store-and-forward:** telecommunications technique in which information is sent to an intermediate station where it is kept and sent at a later time to the final destination or to another intermediate station.

**Subject Invention:** Any invention conceived or first actually reduced to practice under an ARPA-E funding agreement.

**Switch:** computer networking device that connects devices together on a computer network, by using packet switching to receive, process and forward data to the destination device.

**Task:** A task is an operation or segment of the work plan that requires both effort and resources. Each task (or sub-task) is connected to the overall objective of the project, via the achievement of a milestone or a deliverable.

**Top of the Rack:** portion of the network interconnect above the server racks

**Total Project Cost:** The sum of the Prime Recipient share and the Federal Government share of total allowable costs. The Federal Government share generally includes costs incurred by GOGOs, FFRDCs, and GOCOs.

**Transceiver:** device comprising both a transmitter and a receiver which are combined and share common circuitry or a single housing

**TT&O:** Technology Transfer and Outreach. (See Section IV.G.8 of the FOA for more information).

**VCSEL:** vertical-cavity surface-emitting laser