

**FINANCIAL ASSISTANCE
FUNDING OPPORTUNITY ANNOUNCEMENT**



**ADVANCED RESEARCH PROJECTS AGENCY – ENERGY (ARPA-E)
U.S. DEPARTMENT OF ENERGY**

**AVIATION-CLASS SYNERGISTICALLY COOLED ELECTRIC-
MOTORS WITH INTEGRATED DRIVES (ASCEND)**

Announcement Type: **Initial Announcement Modification 01**
Funding Opportunity No. DE-FOA-0002238
CFDA Number 81.135

Funding Opportunity Announcement (FOA) Issue Date:	December 16, 2019
First Deadline for Questions to ARPA-E-CO@hq.doe.gov:	5 PM ET, Tuesday, January 21, 2020
Submission Deadline for Concept Papers:	9:30 AM ET, Friday, January 31, 2020
Second Deadline for Questions to ARPA-E-CO@hq.doe.gov:	5 PM ET, Tuesday, May 12, 2020
Submission Deadline for Full Applications:	9:30 AM ET, Friday, May 22, 2020
Submission Deadline for Replies to Reviewer Comments:	5 PM ET, Monday, July 13, 2020
Expected Date for Selection Notifications:	August July 2020
Total Amount to Be Awarded	Approximately \$35 million, subject to the availability of appropriated funds to be shared between FOAs DE-FOA-0002238 and DE-FOA-0002239.
Anticipated Awards	ARPA-E may issue one, multiple, or no awards under this FOA. Awards may vary between \$250,000 and \$10 million.

- For eligibility criteria, see Section III.A of the FOA.
- For cost share requirements under this FOA, see Section III.B of the FOA.
- To apply to this FOA, Applicants must register with and submit application materials through ARPA-E eXCHANGE (<https://arpa-e-foa.energy.gov/Registration.aspx>). For detailed guidance on using ARPA-E eXCHANGE, see Section IV.H.1 of the FOA.
- Applicants are responsible for meeting each submission deadline. Applicants are strongly encouraged to submit their applications at least 48 hours in advance of the submission deadline.
- For detailed guidance on compliance and responsiveness criteria, see Sections III.C.1 through III.C.4 of the FOA.

Questions about this FOA? Check the Frequently Asked Questions available at <http://arpa-e.energy.gov/faq>. For questions that have not already been answered, email ARPA-E-CO@hq.doe.gov (with FOA name and number in subject line); see FOA Sec. VII.A. Problems with ARPA-E eXCHANGE? Email ExchangeHelp@hq.doe.gov (with FOA name and number in subject line).

MODIFICATIONS

All modifications to the Funding Opportunity Announcement (FOA) are highlighted in yellow in the body of the FOA.

Mod. No.	Date	Description of Modifications
01	3/23/2020	<ul style="list-style-type: none"> • Inserted certain deadlines, including the deadlines for submitting questions and Full Applications. Modified Anticipated Award Range. See Cover Page and Required Documents Checklist. • Changed naming from ASCEND Phase I and ASCEND Phase II to ASCEND Phase 1 and ASCEND Phase 2, to clearly distinguish from SBIR/STTR Phases (i.e., Phases I, II, and IIS). • Updated Section I.D.3 Program Structures and Deliverables • Updated Section II.A Award Overview. • Revised the following sections of the FOA to provide guidance on required application forms and the content and form of Full Applications and Replies to Reviewer Comments: Required Documents Checklist and Sections IV.A, IV.D, IV.E, and IV.G of the FOA. Applicants are strongly encouraged to use the templates provided on ARPA-E eXCHANGE (https://arpa-e-foa.energy.gov). • Inserted criteria that ARPA-E will use to evaluate Full Applications, see Section V.A.2 of the FOA. • Inserted criteria that ARPA-E will use to evaluate Replies to Reviewer Comments in Section V.A.3 of the FOA. • Inserted an additional Program Policy Factor in Section V.B.1. • Inserted information on the anticipated announcement and award dates, see Section V.C of the FOA. • Inserted information concerning Full Application Notifications, see Section VI.A.3 of the FOA. • Inserted Administrative and National Policy Requirements, see Section VI.B of the FOA. • Inserted Reporting Requirements see Section VI.C of the FOA. • Inserted additional Definitions, see Section IX of the FOA.

Questions about this FOA? Check the Frequently Asked Questions available at <http://arpa-e.energy.gov/faq>. For questions that have not already been answered, email ARPA-E-CO@hq.doe.gov (with FOA name and number in subject line); see FOA Sec. VII.A. Problems with ARPA-E eXCHANGE? Email ExchangeHelp@hq.doe.gov (with FOA name and number in subject line).

TABLE OF CONTENTS

REQUIRED DOCUMENTS CHECKLIST.....- 1 -

I. FUNDING OPPORTUNITY DESCRIPTION- 2 -

A. AGENCY OVERVIEW- 2 -

B. PROGRAM OVERVIEW- 3 -

1. EXECUTIVE SUMMARY.....- 3 -

2. PROGRAM MOTIVATION.....- 5 -

C. PROGRAM OBJECTIVES AND TECHNICAL AREAS OF INTEREST.....- 8 -

D. PROGRAM BOUNDARY, TECHNICAL PERFORMANCE TARGETS AND DELIVERABLES.....- 12 -

1. PROGRAM BOUNDARY.....- 12 -

2. TECHNICAL PERFORMANCE TARGETS.....- 15 -

3. PROGRAM STRUCTURE AND DELIVERABLES.....- 17 -

II. AWARD INFORMATION.....- 20 -

A. AWARD OVERVIEW.....- 20 -

B. RENEWAL AWARDS.....- 21 -

C. ARPA-E FUNDING AGREEMENTS- 21 -

1. COOPERATIVE AGREEMENTS.....- 21 -

2. FUNDING AGREEMENTS WITH FFRDCs/DOE LABS, GOGOS, AND FEDERAL INSTRUMENTALITIES.....- 21 -

3. OTHER TRANSACTIONS AUTHORITY.....- 22 -

D. STATEMENT OF SUBSTANTIAL INVOLVEMENT- 23 -

III. ELIGIBILITY INFORMATION- 24 -

A. ELIGIBLE APPLICANTS- 24 -

1. INDIVIDUALS.....- 24 -

2. DOMESTIC ENTITIES.....- 24 -

3. FOREIGN ENTITIES.....- 24 -

4. CONSORTIUM ENTITIES.....- 25 -

B. COST SHARING- 25 -

1. BASE COST SHARE REQUIREMENT.....- 26 -

2. INCREASED COST SHARE REQUIREMENT.....- 26 -

3. REDUCED COST SHARE REQUIREMENT.....- 26 -

4. LEGAL RESPONSIBILITY.....- 27 -

5. COST SHARE ALLOCATION.....- 27 -

6. COST SHARE TYPES AND ALLOWABILITY.....- 27 -

7. COST SHARE CONTRIBUTIONS BY FFRDCs AND GOGOS.....- 28 -

8. COST SHARE VERIFICATION- 29 -

C. OTHER.....- 29 -

1. COMPLIANT CRITERIA.....- 29 -

2. RESPONSIVENESS CRITERIA.....- 30 -

3. SUBMISSIONS SPECIFICALLY NOT OF INTEREST.....- 31 -

4. LIMITATION ON NUMBER OF SUBMISSIONS.....- 31 -

IV. APPLICATION AND SUBMISSION INFORMATION.....- 32 -

A. APPLICATION PROCESS OVERVIEW.....- 32 -

Questions about this FOA? Check the Frequently Asked Questions available at <http://arpa-e.energy.gov/faq>. For questions that have not already been answered, email ARPA-E-CO@hq.doe.gov (with FOA name and number in subject line); see FOA Sec. VII.A. Problems with ARPA-E eXCHANGE? Email ExchangeHelp@hq.doe.gov (with FOA name and number in subject line).

1.	REGISTRATION IN ARPA-E eXCHANGE.....	- 32 -
2.	CONCEPT PAPERS.....	- 32 -
3.	FULL APPLICATIONS.....	- 32 -
4.	REPLY TO REVIEWER COMMENTS.....	- 33 -
5.	PRE-SELECTION CLARIFICATIONS AND “DOWN-SELECT” PROCESS.....	- 33 -
6.	SELECTION FOR AWARD NEGOTIATIONS.....	- 33 -
B.	APPLICATION FORMS.....	- 34 -
C.	CONTENT AND FORM OF CONCEPT PAPERS.....	- 34 -
1.	CONCEPT PAPER.....	- 35 -
A.	CONCEPT SUMMARY.....	- 35 -
B.	INNOVATION AND IMPACT.....	- 35 -
C.	PROPOSED WORK.....	- 35 -
D.	TEAM ORGANIZATION AND CAPABILITIES.....	- 36 -
D.	CONTENT AND FORM OF FULL APPLICATIONS.....	- 36 -
1.	FIRST COMPONENT: TECHNICAL VOLUME.....	- 37 -
2.	SECOND COMPONENT: SF-424.....	- 37 -
3.	THIRD COMPONENT: BUDGET JUSTIFICATION WORKBOOK/SF-424A.....	- 38 -
4.	FOURTH COMPONENT: SUMMARY FOR PUBLIC RELEASE.....	- 39 -
5.	FIFTH COMPONENT: SUMMARY SLIDE.....	- 40 -
6.	SIXTH COMPONENT: BUSINESS ASSURANCES & DISCLOSURES FORM.....	- 40 -
7.	SEVENTH COMPONENT: U.S. MANUFACTURING PLAN.....	- 41 -
E.	CONTENT AND FORM OF REPLIES TO REVIEWER COMMENTS.....	- 42 -
F.	INTERGOVERNMENTAL REVIEW.....	- 43 -
G.	FUNDING RESTRICTIONS.....	- 43 -
1.	ALLOWABLE COSTS.....	- 43 -
2.	PRE-AWARD COSTS.....	- 43 -
3.	PATENT COSTS.....	- 43 -
4.	CONSTRUCTION.....	- 44 -
5.	FOREIGN TRAVEL.....	- 44 -
6.	PERFORMANCE OF WORK IN THE UNITED STATES.....	- 44 -
7.	PURCHASE OF NEW EQUIPMENT.....	- 44 -
8.	TECHNOLOGY TRANSFER AND OUTREACH.....	- 45 -
9.	LOBBYING.....	- 45 -
10.	CONFERENCE SPENDING.....	- 46 -
11.	INDEPENDENT RESEARCH AND DEVELOPMENT COSTS.....	- 46 -
H.	OTHER SUBMISSION REQUIREMENTS.....	- 47 -
1.	USE OF ARPA-E eXCHANGE.....	- 47 -
V.	APPLICATION REVIEW INFORMATION.....	- 49 -
A.	CRITERIA.....	- 49 -
1.	CRITERIA FOR CONCEPT PAPERS.....	- 49 -
2.	CRITERIA FOR FULL APPLICATIONS.....	- 50 -
3.	CRITERIA FOR REPLIES TO REVIEWER COMMENTS.....	- 51 -
B.	REVIEW AND SELECTION PROCESS.....	- 51 -
1.	PROGRAM POLICY FACTORS.....	- 51 -
2.	ARPA-E REVIEWERS.....	- 52 -

Questions about this FOA? Check the Frequently Asked Questions available at <http://arpa-e.energy.gov/faq>. For questions that have not already been answered, email ARPA-E-CO@hq.doe.gov (with FOA name and number in subject line); see FOA Sec. VII.A. Problems with ARPA-E eXCHANGE? Email ExchangeHelp@hq.doe.gov (with FOA name and number in subject line).

3.	ARPA-E SUPPORT CONTRACTOR	- 53 -
C.	ANTICIPATED ANNOUNCEMENT AND AWARD DATES	- 53 -
VI.	AWARD ADMINISTRATION INFORMATION	- 54 -
A.	AWARD NOTICES	- 54 -
1.	REJECTED SUBMISSIONS	- 54 -
2.	CONCEPT PAPER NOTIFICATIONS	- 54 -
3.	FULL APPLICATION NOTIFICATIONS	- 54 -
B.	ADMINISTRATIVE AND NATIONAL POLICY REQUIREMENTS	- 55 -
1.	DUNS NUMBER AND SAM, FSRS, AND FEDCONNECT REGISTRATIONS	- 55 -
2.	NATIONAL POLICY ASSURANCES	- 56 -
3.	PROOF OF COST SHARE COMMITMENT AND ALLOWABILITY	- 56 -
4.	COST SHARE PAYMENTS	- 57 -
5.	ENVIRONMENTAL IMPACT QUESTIONNAIRE	- 57 -
6.	TECHNOLOGY-TO-MARKET PLAN	- 57 -
7.	INTELLECTUAL PROPERTY AND DATA MANAGEMENT PLANS	- 57 -
8.	U.S. MANUFACTURING REQUIREMENT	- 58 -
9.	CORPORATE FELONY CONVICTIONS AND FEDERAL TAX LIABILITY	- 60 -
10.	APPLICANT RISK ANALYSIS	- 60 -
11.	RECIPIENT INTEGRITY AND PERFORMANCE MATTERS	- 61 -
12.	NONDISCLOSURE AND CONFIDENTIALITY AGREEMENTS REPRESENTATIONS	- 61 -
C.	REPORTING	- 62 -
VII.	AGENCY CONTACTS	- 63 -
A.	COMMUNICATIONS WITH ARPA-E	- 63 -
B.	DEBRIEFINGS	- 64 -
VIII.	OTHER INFORMATION	- 65 -
A.	TITLE TO SUBJECT INVENTIONS	- 65 -
B.	GOVERNMENT RIGHTS IN SUBJECT INVENTIONS	- 65 -
1.	GOVERNMENT USE LICENSE	- 66 -
2.	MARCH-IN RIGHTS	- 66 -
C.	RIGHTS IN TECHNICAL DATA	- 66 -
D.	PROTECTED PERSONALLY IDENTIFIABLE INFORMATION	- 67 -
E.	FOAs AND FOA MODIFICATIONS	- 67 -
F.	OBLIGATION OF PUBLIC FUNDS	- 67 -
G.	REQUIREMENT FOR FULL AND COMPLETE DISCLOSURE	- 68 -
H.	RETENTION OF SUBMISSIONS	- 68 -
I.	MARKING OF CONFIDENTIAL INFORMATION	- 68 -
J.	COMPLIANCE AUDIT REQUIREMENT	- 69 -
IX.	GLOSSARY	- 70 -

Questions about this FOA? Check the Frequently Asked Questions available at <http://arpa-e.energy.gov/faq>. For questions that have not already been answered, email ARPA-E-CO@hq.doe.gov (with FOA name and number in subject line); see FOA Sec. VII.A. Problems with ARPA-E eXCHANGE? Email ExchangeHelp@hq.doe.gov (with FOA name and number in subject line).

REQUIRED DOCUMENTS CHECKLIST

For an overview of the application process, see Section IV.A of the FOA.

For guidance regarding requisite application forms, see Section IV.B of the FOA.

For guidance regarding the content and form of Concept Papers, Full Applications, and Replies to Reviewer Comments, see Sections IV.C, IV.D, and IV.E of the FOA.

SUBMISSION	COMPONENTS	OPTIONAL/ MANDATORY	FOA SECTION	DEADLINE
Concept Paper	<ul style="list-style-type: none"> • Each Applicant must submit a Concept Paper in Adobe PDF format by the stated deadline. The Concept Paper must not exceed four (4) pages in length including graphics, figures and/or tables and must include the following. (Tables 2.a and 2.b, provided in the Concept Paper template, will not count as part of the four pages.): <ul style="list-style-type: none"> ○ Concept Summary ○ Innovation and Impact ○ Proposed Work ○ Team Organization and Capabilities ○ Tables 2.a and 2.b (2 pages max.) 	Mandatory	IV.C	9:30 AM ET, Friday, January 31, 2020
Full Application	<ul style="list-style-type: none"> • Each Applicant must submit a Technical Volume in Adobe PDF format by the stated deadline. The Technical Volume must include the following: <ul style="list-style-type: none"> ○ Executive Summary (1 page max.) ○ Sections 1-5 (20 pages max.) <ul style="list-style-type: none"> • 1. Innovation and Impact • 2. Proposed Work • 3. Team Organization and Capabilities • 4. Technology to Market • 5. Budget ○ Bibliographic References (no page limit) ○ Personal Qualification Summaries (each PQS limited to 3 pages in length, no cumulative page limit) ○ Completed Tables 2.a and 2.b (2 pages max.) • The Technical Volume must be accompanied by: <ul style="list-style-type: none"> ○ SF-424 (no page limit, Adobe PDF format); ○ Budget Justification Workbook/SF424A (no page limit, Microsoft Excel format) ○ Summary for Public Release (250 words max., Adobe PDF format); ○ Summary Slide (1 page limit, Microsoft PowerPoint format); and ○ Completed and signed Business Assurances & Disclosures Form (no page limit, Adobe PDF format). 	Mandatory	IV.D	9:30 AM ET, Friday, May 22, 2020
Reply to Reviewer Comments	<ul style="list-style-type: none"> • Each Applicant may submit a Reply to Reviewer Comments in Adobe PDF format. This submission is optional. The Reply may include: <ul style="list-style-type: none"> ○ Up to 2 pages of text; and ○ Up to 1 page of images. 	Optional	IV.E	5 PM ET, Monday, July 13, 2020

Questions about this FOA? Check the Frequently Asked Questions available at <http://arpa-e.energy.gov/faq>. For questions that have not already been answered, email ARPA-E-CO@hq.doe.gov (with FOA name and number in subject line); see FOA Sec. VII.A. Problems with ARPA-E eXCHANGE? Email ExchangeHelp@hq.doe.gov (with FOA name and number in subject line).

I. FUNDING OPPORTUNITY DESCRIPTION

A. AGENCY OVERVIEW

The Advanced Research Projects Agency – Energy (ARPA-E), an organization within the Department of Energy (DOE), is chartered by Congress in the America COMPETES Act of 2007 (P.L. 110-69), as amended by the America COMPETES Reauthorization Act of 2010 (P.L. 111-358) to:

- “(A) to enhance the economic and energy security of the United States through the development of energy technologies that result in—
- (i) reductions of imports of energy from foreign sources;
 - (ii) reductions of energy-related emissions, including greenhouse gases; and
 - (iii) improvement in the energy efficiency of all economic sectors; and
- (B) to ensure that the United States maintains a technological lead in developing and deploying advanced energy technologies.”

ARPA-E issues this Funding Opportunity Announcement (FOA) under the programmatic authorizing statute codified at 42 U.S.C. § 16538. The FOA and any awards made under this FOA are subject to 2 C.F.R. Part 200 as amended by 2 C.F.R. Part 910.

ARPA-E funds research on and the development of high-potential, high-impact energy technologies that are too early for private-sector investment. The agency focuses on technologies that can be meaningfully advanced with a modest investment over a defined period of time in order to catalyze the translation from scientific discovery to early-stage technology. For the latest news and information about ARPA-E, its programs and the research projects currently supported, see: <http://arpa-e.energy.gov/>.

ARPA-E funds transformational research. Existing energy technologies generally progress on established “learning curves” where refinements to a technology and the economies of scale that accrue as manufacturing and distribution to develop drive down the cost/performance metric in a gradual fashion. This continual improvement of a technology is important to its increased commercial deployment and is appropriately the focus of the private sector or the applied technology offices within DOE. By contrast, ARPA-E supports transformative research that has the potential to create fundamentally new learning curves. ARPA-E technology projects typically start with cost/performance estimates well above the level of an incumbent technology. Given the high risk inherent in these projects, many will fail to progress, but some may succeed in generating a new learning curve with a projected cost/performance metric that is significantly lower than that of the incumbent technology.

ARPA-E funds technology with the potential to be disruptive in the marketplace. The mere creation of a new learning curve does not ensure market penetration. Rather, the ultimate value of a technology is determined by the marketplace, and impactful technologies ultimately become disruptive – that is, they are widely adopted and displace existing technologies from

Questions about this FOA? Check the Frequently Asked Questions available at <http://arpa-e.energy.gov/faq>. For questions that have not already been answered, email ARPA-E-CO@hq.doe.gov (with FOA name and number in subject line); see FOA Sec. VII.A. Problems with ARPA-E eXCHANGE? Email ExchangeHelp@hq.doe.gov (with FOA name and number in subject line).

the marketplace or create entirely new markets. ARPA-E understands that definitive proof of market disruption takes time, particularly for energy technologies. Therefore, ARPA-E funds the development of technologies that, if technically successful, have the clear disruptive potential, e.g., by demonstrating capability for manufacturing at competitive cost and deployment at scale.

ARPA-E funds applied research and development. The Office of Management and Budget defines “applied research” as an “original investigation undertaken in order to acquire new knowledge...directed primarily towards a specific practical aim or objective” and defines “experimental development” as “creative and systematic work, drawing on knowledge gained from research and practical experience, which is directed at producing new products or processes or improving existing products or processes.”¹ Applicants interested in receiving financial assistance for basic research should contact the DOE’s Office of Science (<http://science.energy.gov/>). Office of Science national scientific user facilities (<http://science.energy.gov/user-facilities/>) are open to all researchers, including ARPA-E Applicants and awardees. These facilities provide advanced tools of modern science including accelerators, colliders, supercomputers, light sources and neutron sources, as well as facilities for studying the nanoworld, the environment, and the atmosphere. Projects focused on early-stage R&D for the improvement of technology along defined roadmaps may be more appropriate for support through the DOE applied energy offices including: the Office of Energy Efficiency and Renewable Energy (<http://www.eere.energy.gov/>), the Office of Fossil Energy (<http://fossil.energy.gov/>), the Office of Nuclear Energy (<http://www.energy.gov/ne/office-nuclear-energy>), and the Office of Electricity Delivery and Energy Reliability (<http://energy.gov/oe/office-electricity-delivery-and-energy-reliability>).

B. PROGRAM OVERVIEW

1. EXECUTIVE SUMMARY

The Aviation-class Synergistically Cooled Electric-motors with iNtegrated Drives (ASCEND) program supports the development of novel lightweight and ultra-efficient electric motors, drives², and associated thermal management system (collectively referred to as the all-electric powertrain) that will facilitate net-zero carbon emissions in the single-aisle, 150-200 passenger commercial aircraft segment. This FOA represents part of a wider ARPA-E effort in the development of enabling technologies for long-range ($\geq 2,800$ nautical miles), carbon neutral commercial aviation. The other part of the wider ARPA-E effort is included in a separate FOA targeting ultra-efficient and lightweight energy storage and fuel-to-electric power conversion

¹ OMB Circular A-11 (https://www.whitehouse.gov/wp-content/uploads/2018/06/a11_web_toc.pdf), Section 84, pg. 3.

² A drive is the electronic device that harnesses and controls the electrical energy sent to the motor, utilizing power electronics and associated control logic. The drive can feed electricity into the motor in varying amounts and at varying frequencies, thereby enabling control of the motor's speed and torque.

system³. The overarching goal of the two FOAs is to reduce the emissions from commercial aviation by developing cost-competitive systems for the efficient conversion of the chemical energy of carbon-neutral liquid fuels (CNLFs)⁴ to delivered electric energy, which is then further converted to thrust via propulsors driven by electric motors and associated motor drives. The focus of the ASCEND program is the development of an all-electric powertrain as the prime mover for long-range, narrow-body aircraft such as the Boeing 737. Current electric powertrains do not have high enough power density and efficiency to enable competitive and fully decarbonized aviation for the narrow-body class of aircraft.

The ASCEND program aims to take advantage of emerging materials, manufacturing techniques, and design topologies, with a focus on the co-design of electromagnetics, power electronics, and thermal management solutions. The ASCEND program requires demanding figures of merit for specific power (≥ 12 kW/kg) and efficiency ($\geq 93\%$) for the fully integrated all-electric powertrain systems; these targets, among others, are well beyond the capability of current state-of-the-art technologies and will require creative thinking and innovation in the electric motor and power electronics space.

The ASCEND program will incorporate two phases. Phase 1 calls for conceptual designs and computer simulations of motor, its drive, and their integration, as well as subsystem/component level demonstrations, as necessary, for the proposed key enabling technologies to support the design and simulated performance projections. Phase 1 will be 18 months long. Subject to the availability of appropriated funds, projects that achieve technical success in Phase 1 may, at ARPA-E's sole discretion, proceed to the second phase of the program to develop, fabricate, and test an integrated motor and drive developmental prototype (≥ 250 kW) comprised of an electric motor, its drive and associated thermal management system (TMS). See section I.D.3 (Program Structure and Deliverables) for further details.

If successful, the ASCEND program will accelerate innovations and cause disruptive changes in the emerging electric aviation field, which is poised to play a significant role in the near- and long-term. The program will also further enhance the U.S. technology dominance in the field of high-performance electric motors for hybrid electric aviation and a full range of other industrial applications beyond aviation, such as electric vehicles, maritime technologies, wind turbines, and off-shore drilling.

³ Range Extenders for Electric Aviation with Low Carbon Emission and High Efficiency (REEACH), DE-FOA-0002240 and DE-FOA-0002241.

⁴ CNLFs are defined in REEACH as energy dense liquid fuels with no net greenhouse gas emissions or net carbon footprint. They are made by converting molecules contained in air (N_2 , CO_2), water, and/or biomass using renewable energy into energy-carrying fuels that are liquid at moderate temperatures and pressures (e.g. sustainable hydrocarbons and oxygenates).

2. PROGRAM MOTIVATION

Air travel accounts for a considerable and growing portion of U.S. energy imports and greenhouse gas (GHG) emissions. In 2017, the U.S. consumed nearly 3.5 quads equivalent of jet fuel⁵. This accounted for about 3.5% of primary energy consumption, equivalent to about 16% by volume of petroleum (crude oil and products) imports⁶. In the same year, air travel accounted for about 174.8 million metric tons of CO₂ equivalent emissions in the U.S., or about 2.6% of domestic GHG emissions⁷. These numbers are only expected to grow: revenue passenger-miles for flights originating and/or terminating in the U.S. and flown by U.S. certificated carriers nearly doubled⁸ between 2002 and 2018, and global growth rates are expected to increase⁹.

Decarbonizing and reducing energy consumption in the aviation sector is challenging^{10, 11}. To address these challenges, ARPA-E intends to focus on critical and enabling technologies for electrified aircraft propulsion across several programs. It is estimated that narrow-body aircrafts, or single-aisle aircraft, such as the Boeing 737, are responsible for nearly half of aviation-related GHG emissions¹². This type of aircraft constitutes the majority of commercial aircraft flying worldwide today and accounts for the most passenger-miles traveled in the U.S.¹³. It is anticipated that the majority of the global growth in passenger-miles flown will come from these single-aisle commercial aircraft. Consequently, of all aircraft types, a decarbonized B737-like aircraft would provide the greatest energy and emissions impact. Hence, ARPA-E has selected the narrow-body, single-aisle, turbofan-powered Boeing 737-800 aircraft as the benchmark from which the program goals are derived.

Many possible pathways exist toward a decarbonized aviation sector powered by domestically produced fuels. These include partially or fully electrified powertrains¹¹, though they face multiple technical challenges. Hybridized architectures may combine gas turbines or other combustion engines with electric generators, batteries (for supplemental power), and/or fuel cells. Such configurations capitalize on the performance strengths of the individual technologies to address the power and energy demands of different flight stages, leading to increased overall fuel to thrust efficiency and hence reduced fuel burn¹¹. Furthermore, the use of electric

⁵ https://www.eia.gov/state/seds/data.php?incfile=/state/seds/sep_fuel/html/fuel_jf.html

⁶ https://www.eia.gov/totalenergy/data/monthly/pdf/sec3_9.pdf

⁷ <https://www.epa.gov/greenvehicles/fast-facts-transportation-greenhouse-gas-emissions>

⁸ https://www.transtats.bts.gov/Data_Elements.aspx?Data=3

⁹ <https://www.iata.org/publications/store/Pages/20-year-passenger-forecast.aspx>

¹⁰ S.J. Davis et al., "Net-zero emissions energy systems," *Science* 360 (6396), 29 June 2018.

¹¹ National Academies of Sciences, Engineering, and Medicine, *Commercial Aircraft Propulsion and Energy Systems Research: Reducing Global Carbon Emissions*, The National Academies Press, 2016.

<https://doi.org/10.17226/23490>.

¹² B. Graver et al. "CO₂ emissions from commercial aviation, 2018", Working Paper 2019-16, International Council On Clean Transportation,

https://theicct.org/sites/default/files/publications/ICCT_CO2-commercl-aviation-2018_20190918.pdf

¹³ https://www.transtats.bts.gov/tables.asp?DB_ID=130, Table T2

motors as prime movers favors the development of clean-sheet aircraft designs and offers greater flexibility with better airframe integration, such as distributed electric propulsion and boundary layer ingestion. These revolutionary design paradigms¹⁴ can improve the overall aerodynamic efficiency of the airframe, further reducing the energy required to carry a given payload for a given flight profile¹⁵. Beyond energy impacts, electrified architectures can also reduce aircraft noise emissions and increase reliability by increasing redundancy¹⁴.

Current efforts to electrify aviation are predominantly focused on smaller, lower capacity, urban applications¹⁶ or on drones, which can run fully on battery power. Most flyable, manned all-electric aircraft to date are restricted to low takeoff weights (often less than a ton) and typically have four or fewer seats¹⁷. These demonstrators have served as a test bed for different architectures: series hybrid electric, parallel hybrid electric, and fuel cells, with a majority being all-electric (battery-powered) configurations.

An all-electric propulsion system operating on CNLF would have net-zero emissions. This is the motivation behind the ASCEND program targeting propulsion system efficiency and specific power improvements that would make CNLF-powered, zero-net emission aircraft more economically attractive (e.g., longer range, reduced fuel cost).

Accordingly, ARPA-E seeks to develop electrified powertrains for narrow-body, single-aisle aircraft that operate on carbon-neutral liquid fuels⁴ to disruptively advance the aviation industry towards decarbonization. **This will be accomplished by two programs targeted at two specific technical areas:**

- 1) The development of a highly efficient and lightweight system to convert CNLF to electric power (REEACH FOA)³; and**
- 2) The development of a lightweight and ultra-efficient all-electric powertrain that converts electric power to propulsion (this ASCEND FOA).**

A primary focus in each of the above-referenced two areas will be substantial improvements in the specific power output and energy efficiency of the two systems and their components.

Several electric propulsion architecture options have been proposed¹⁸, but ARPA-E is interested in a system architecture as shown in **Figure 1**. Under the REEACH FOA³, the Energy Storage and Power Generation (ESPG) sub-system is comprised of one or several CNLF -storage systems and

¹⁴ https://www.iata.org/pressroom/facts_figures/fact_sheets/Documents/fact-sheet-technology-roadmap-environment.pdf

¹⁵ K. Moore *et al.*, "Distributed Electric Propulsion Effects on Traditional Aircraft Through Multidisciplinary Optimization", AIAA Structure, Structural Dynamics and Materials Conference, Kissimmee, FL, 2018.

¹⁶ Roland Berger, Think, Act: Aircraft Electrical Propulsion – Onwards and Upwards, 2018.

¹⁷ B. Brelje *et al.*, "Electric, hybrid, and turboelectric fixed wing aircraft: A review of concepts, models, and design approaches", Progress in Aerospace Science, 109 (2019)

¹⁸ NAS Report, 2016. Modified from James L. Felder, NASA Glenn Research Center, "NASA Hybrid Electric Propulsion Systems Structures," presentation to the committee on September 1, 2015.

their fuel content, fuel-to-electricity conversion engines and associated balance of plant, and potentially an optional electric storage device (e.g. battery) that will provide the supplemental electric power needed during takeoff. Details of the ESPG requirements can be found elsewhere³.

On the other hand, the focus of ASCEND is the all-electric powertrain shown schematically in **Figure 1 (green box)**. It is comprised of a high efficiency, high specific power electric motor(s) and, if needed, a torque amplifier (e.g. gearbox), its power electronics and controller, and the thermal management system (TMS) for both the power electronics and the electric motor(s). Details of the all-electric powertrain will follow in subsequent sections of this FOA. The electric power generated will drive a set of next-generation, high efficiency propulsors (at least two, or more in the case of distributed propulsion), each driven by its own all-electric powertrain. A high voltage (≥ 1 kV), fault resistant, DC electric bus distribution system is envisioned to transmit the electric power provided by the fuel conversion ESPG system to the electric drives and motors that drive the propulsors. However, the bus distribution system as well as the propulsor (e.g., propeller, fan) are outside the scope of this ASCEND FOA.

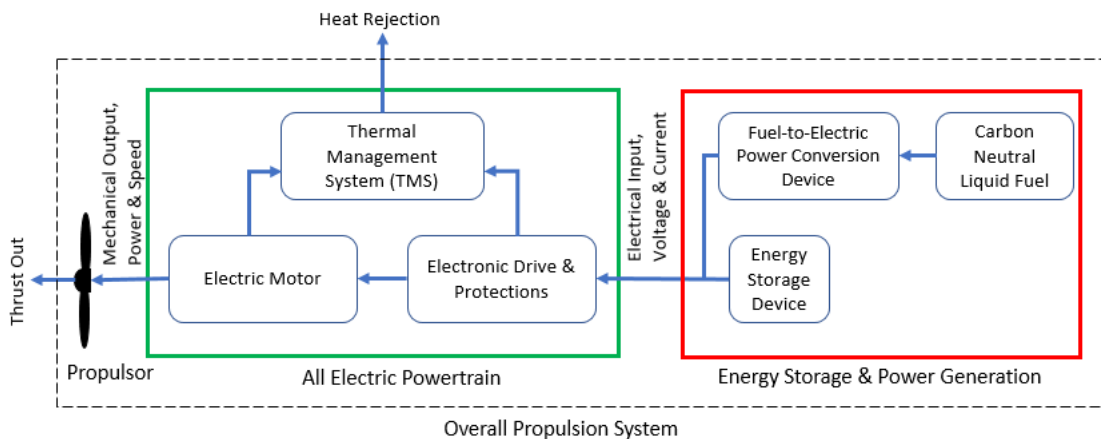

Figure 1: A schematic block diagram of the overall propulsion system and the two sub-systems that ARPA-E is pursuing.

While the dual technological thrusts discussed above will result in integrated systems specifically designed for subsonic narrow-body aircraft, it is anticipated that the successfully developed technologies would also find direct application in the nascent urban air mobility¹⁹, unmanned aerial vehicles (UAVs), and select regional aircraft markets¹⁶¹⁴, which have immediate needs for lightweight and high efficiency motors. As such, these markets are likely to constitute the first adoption in the next 5–10 years. Subsequent deployment of the envisioned technologies into the next generation of narrow-body aircraft may take a decade or more¹⁴.

¹⁹ <https://ntrs.nasa.gov/archive/nasa/casi.ntrs.nasa.gov/20190001472.pdf>

C. PROGRAM OBJECTIVES AND TECHNICAL AREAS OF INTEREST

Aircrafts require high propulsive power during the takeoff and climb phases, and a fraction (25-35%) of the peak propulsive power during the cruise phase. For the narrow-body aircraft considered here, the takeoff and climb period typically can take up to 20 minutes, while most of the remaining flight occurs at cruise conditions (depending on the flight profile). Thus, the cruise phase is responsible for most of the energy consumption. **Figure 2** shows the thrust power calculated for a typical flight of a narrow-body commercial aircraft. Calculations show that while thrust power and system-level power density (kW/kg) are critical during the takeoff and climb phases of the flight, efficiency at both takeoff and cruise phases is important for minimizing the energy consumption. Critical technical performance targets (i.e., power density and efficiency) have been derived to meet the flight profile shown in **Figure 2**, except the takeoff power has been downscaled to ≥ 250 kW, which is deemed sufficient for the purpose of this FOA for a proof of concept demonstration of the proposed innovations.

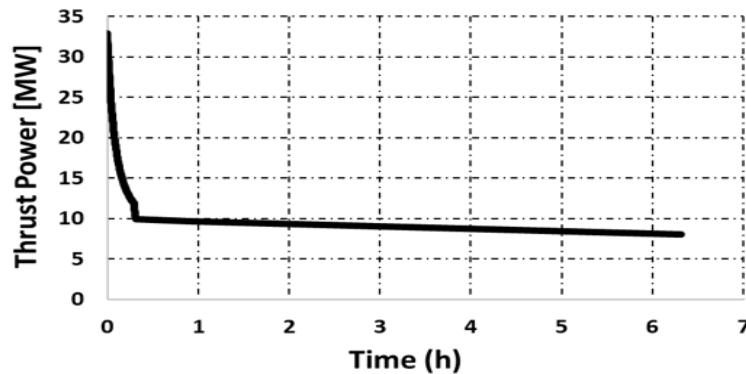

Figure 2: Modeled delivered thrust power profile for a typical flight of a narrow-body commercial airliner.

ARPA-E’s internal analysis has determined that to complete a 5-hour-plus flight profile typical of a narrow-body commercial airliner with performance similar to that of present-day aircraft, the takeoff (peak) specific power density and cruise nominal efficiency of the all-electric propulsion system must be ≥ 12 kW/kg and $\geq 93\%$, respectively. These are technically demanding figures and are well beyond state-of-the-art technologies. Meeting these requirements will require creative thinking and innovation in the electric motor and drive. In the power electronics area, advances in wide band gap semiconductors are already making a fully packaged inverter unit of 20 kW/kg and efficiency of 98.5% within reach²⁰. However, this does not account for the entire weight of the associated TMS, and thus the resulting integrated power electronic system may have somewhat lower respective power density and efficiency. Nevertheless, with higher bus voltage (≥ 1 kV DC), and utilization of innovative cooling techniques, coupled with optimized integration with rest of the system, ARPA-E anticipates that a power density of 30 kW/kg

²⁰ <https://arpa-e.energy.gov/?q=slick-sheet-project/inverters-heavy-equipment-applications>

(including TMS) and a 98% efficiency for the power electronics subsystem may be achievable. Additional details on ARPA-E's determination of these target metrics can be found in references^{3, 21}.

Electric machines, on the other hand, suffer from relatively low power densities compared to their respective drives. The best-in-class commercially-available electric motor today is believed to have a power density of 5 kW/kg²², and this is often without factoring in the entire weight of the supporting TMS for the motor. Therefore, to achieve the overall performance targets for this FOA, both the power density and efficiency of the electric motors must be substantially improved. To achieve high power density and efficiency simultaneously, the two most commonly considered approaches are (i) to reduce motor losses and (ii) to improve the heat rejection from the motor. In the past, significant reductions in motor losses have been achieved by using new materials technologies. Low-loss magnetic circuit steel materials, high energy density permanent magnet (PM) materials, and the selective and increased use of copper and aluminum conductors have collectively provided low-loss excitation for the electric machines. But reducing losses further has proven difficult and will require a combination of novel design topologies, advanced cooling, and co-design of thermal and electromagnetic components.

For the second approach, improving the heat rejection from the motor, opportunities exist in the development of integrated, low thermal resistance cooling techniques. These novel design topologies are aimed at achieving compact, conformal systems with high heat removal rates while keeping the associated fluid coolant pumping power low. In most cases, cooling technologies for motors and their associated drives/power electronics have fallen behind the rapid progress in cooling technologies that have been widely adopted in micro-electronics and to some extent in selected power electronics^{23, 24}. Among other areas, the approaches described below are examples that can enable further cost-effective efficiency enhancements and weight reductions while addressing the limitations of existing materials and cooling technologies.

(1) Advanced winding and motor topologies. It is desired to decrease the stator's end winding length and mass to reduce associated losses, thus increasing efficiency and specific power of electric motors. Advances in additive manufacturing (AM) and other advanced manufacturing technologies make it possible to introduce novel end winding designs and to introduce advanced insulation materials within the windings to facilitate high thermal conductivity while meeting electrical insulation requirements²⁵. Such

²¹ "ARPA-E Electric Motors for aviation workshop", Michael Ohadi, program director. https://arpa-e.energy.gov/sites/default/files/2_Ohadi_Workshop%20Presentation--Public%20release%20version.pdf

²² Specification of Siemens SP260D & SP260D-A aviation motor.

²³ J. Broughton *et al.*, "Review of Thermal Packaging Technologies for Automotive Power Electronics for Traction Purposes", *Journal of Electronic Packaging*, Vol. 140 (2018). <https://doi.org/10.1115/1.4040828>

²⁴ S. Yuruker *et al.*, "Advanced Packaging and Thermal Management of High-Power Dc-Dc Converters", *Proceedings of the ASME 2019, Anaheim, CA, October 2019*.

²⁵ <https://arpa-e.energy.gov/?q=slick-sheet-project/additive-manufacturing-electric-vehicle-motors>

improvements can increase the gravimetric power density of the motor, provided that the conductor conductivity will not degrade with the AM process—a shortfall that some AM technologies may need to overcome through innovative winding topologies (e.g. shaping of the conductors)²⁶. Coreless architecture is another area where electric motor designers can explore innovative winding topologies and materials to reduce high-frequency eddy current losses. Such designs also could potentially operate at ultra-high speeds and achieve relatively high specific power while maintaining relatively high efficiency²⁷. AM and/or other advanced manufacturing techniques may also allow the use of complex geometries that could enhance the airgap magnetic flux and incorporate high effectiveness and integrated cooling mechanisms within the motor winding designs²⁸.

(2) Advanced insulating materials. A principal bottleneck in dissipating the heat generated from copper losses inside a motor can be the slot insulation material that sits between the winding and stator lamination. Materials utilized as electrical insulators inside the motor inherently have poor thermal properties. For example, thermal conductivity of a typical insulation material, such as Nomex, is less than 0.2 W/m-K. Potting and varnishing materials used to protect motor windings from shock and vibration, which simultaneously provide some thermal relief (better than air), have thermal conductivity of only ~1 W/m-K. Such poor thermal properties of these materials limits heat rejection from the windings, thus limiting the achievable motor power density and efficiency. In the power electronics area, use of Boron Nitride/Aluminum Nitride (BN/AlN)-based coating and potting materials filled with graphite/carbon nanotubes has improved the heat rejection process from the switching device to the heat sink. Similar processes have recently been adopted in electric motors as well, and 10x improvement in thermal conductivity over industry standards has been reported²⁹.

Advanced insulation materials can also mitigate large voltage stress (dV/dt), corona and partial discharge issues at high altitudes under conditions of reduced ambient air pressure. The traditional method of using thicker insulation materials to accommodate the higher voltages required for greater system efficiency are very unlikely to meet the FOA metrics because of the thermal and weight concerns discussed above. Recent R&D efforts show multilayer insulation techniques that can achieve 60 kV breakdown voltage with only 0.55 mm of insulator thickness, which could pave the path for safe high altitude, high voltage motor operation³⁰.

²⁶ S.J. Raab *et al*, “Thermal and Electrical Conductivity of 99.9% Pure Copper Processed via Selective Electron Beam Melting”, *Advanced Engineering Materials*, Vol. 18 (2016). <https://doi.org/10.1002/adem.201600078>.

²⁷ K. Haran *et al*, “A high-speed, high-frequency, air-core PM machine for aircraft application”, IEEE PECEI 2016.

²⁸ A. Kallaste *et al*, “Additive Design Possibilities of Electric Machines”, IEEE RTUCON 2018.

²⁹ W. Yin *et al*, “Highly Thermally Conductive Insulation for High Power Density Electric Motors”, AIAA/EATS conference, August 2019.

³⁰ E. Shin, “Development of High Voltage Micro-Multilayer Multifunctional Electrical Insulation (MMEI) System”, AIAA/EATS conference, August 2019.

(3) Advanced cooling techniques. For most commonly known designs, the gravimetric torque density of an electric motor is a strong function of the current density, which in turn is directly influenced by the rate of heat rejection from the motor. Commercial state-of-the-art electric motors are generally thermally limited at high power ratings. Power and torque density capability, as well as efficiency, can be increased by mitigating the thermal limitations of the motors through a co-design approach. Such approach would utilize electromagnetics and thermomechanical design aspects. Current methods for commercial motor cooling, such as oil bath or water jacket cooling, impose limitations on power density due to lack of integrated, low-thermal resistance, and highly effective motor cooling practices. This is particularly true for motors that operate at higher voltages, which in most cases require thicker electrical insulation layers that further limit the heat dissipation. Researchers have shown that significant potential exists for improved direct (or near source) cooling techniques. For instance, the stator windings generate most of the heat losses in electric motors, and examples show that nearly two thirds of total motor heat generated is due to such resistive losses. By employing inter-winding and intra-winding thermal management, recent studies demonstrate that the power density of electric motors can be increased substantially³¹. Highly potent working fluids that offer excellent thermo-physical and fluid flow properties, such as select supercritical fluids which offer the density of a liquid and viscosity of a gas, can also contribute to substantial additional cooling of motors. This can directly enhance power and torque densities and efficiency. However, some supercritical fluids may impose additional operating pressure limitations for the cooling system and thus added design complexity. A recent review of thermal management technologies for high power density electric motors can be found elsewhere³¹.

(4) Advanced structural materials. It is common practice in motor design to focus on reducing the weight of torque producing (active) materials such as copper and steel. But structural weight can also become significant when high power densities are desired. This is especially true for air core and superconducting designs where structural weight may dominate the weight of active materials. The weight of the motor can be significantly reduced when traditionally employed metals are replaced with alloys and composites such as carbon fiber-reinforced polymer composites, an advanced structural material that is used in some aerospace applications due to its light weight and superior thermal conductivity.

(5) Co-design and integration. A well-planned co-design approach is needed to take advantage of the combined effects of advances such as those referenced above. For example, a simple cooling feature added to an existing baseline motor design may not provide sufficiently compelling results due to electromagnetic saturation. However, when co-designed with the electromagnetics, novel thermal management technologies

³¹ D. Deisenroth et al., "Thermal Management of High-Power Density Electric Motors for Electrification of Aviation and Beyond—a Review", *Energies* 2019, 12(19), 3594; <https://doi.org/10.3390/en12193594>

can be utilized in the electric motors and associated power electronics to benefit the power density and efficiency of the motor and its drive (i.e., power electronics). Co-design of power electronics and electromagnetics can also lead to new topologies with greater torque densities³². Similarly, integration of the power electronics with the electric motor will lead to higher power densities and efficiencies, as this will eliminate lengthy interconnections between the subsystems. And with continuous advancements in high-temperature power electronics devices, the full integration of the motor and power electronics is becoming feasible³³.

As such, this FOA calls for the development of a novel high specific power density and ultrahigh efficiency all-electric powertrain that meets the prescribed operational and reliability metrics pertinent to narrow-body aircraft applications. Further details and specific required metrics for the FOA are provided in section I.D below.

D. PROGRAM BOUNDARY, TECHNICAL PERFORMANCE TARGETS AND DELIVERABLES

1. PROGRAM BOUNDARY

Figure 3 shows a schematic block diagram for the envisioned system. As depicted there, the end deliverable for successful projects which complete Phases **1** and **2** of the program includes development and testing of a ≥ 250 kW-scale, high specific power (≥ 12 kW/kg), high electrical-to-mechanical conversion efficiency ($\geq 93\%$), integrated motor and drive system. The integrated system should be capable of efficient, reliable, and durable operation at high altitudes (between 35,000 and 40,000 ft). Furthermore, the final integrated system should be designed for integration into a high-voltage ($\Delta V^{\text{bus}} \geq 1\text{kV DC}$) distribution bus.

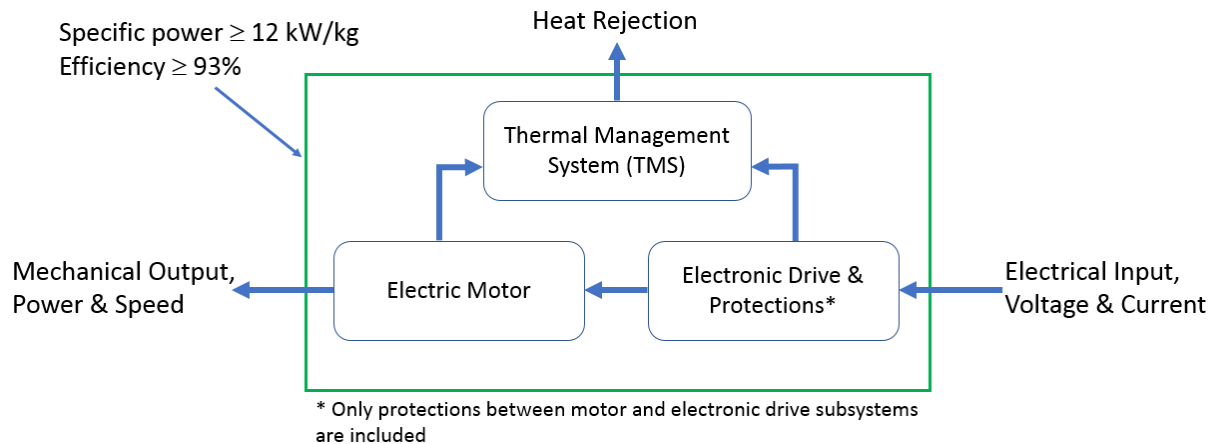

Figure 3: Block diagram for the integrated all-electric powertrain system boundary.

³² <https://arpa-e.energy.gov/?q=slick-sheet-project/more-information-uiucs-project-coming-soon>

³³ <https://arpa-e.energy.gov/?q=slick-sheet-project/inverters-pm-machine-drives>

Three major subsystems are envisioned for development in this category: (1) an electric motor, (2) motor drive/power electronics, and (3) a TMS. The design of the TMS for the electric motor and the power electronics can be a common, shared unit, or can be two separate and independently operated TMS units. The projected specific power for the electric motor subsystem should include any necessary torque amplifier or speed reducer, such as a gearbox, to keep the propulsor speed below 5,000 RPM. Likewise, the projected power density for the power electronics subsystem should include the motor drive unit and the necessary protection mechanisms that are required to protect the motor and power electronics subsystem. Note, however, that the protection circuit between the power electronics and the distribution bus is outside of the scope of the all-electric powertrain system targeted in this FOA.

As expected, the overall efficiency and specific power of the all-electric powertrain depends on the individual characteristics of its respective electric motor (plus its TMS) and motor drive (plus its TMS) sub-systems. This is illustrated in **Figure 4**, where $\Pi_{\text{Motor Drive}}$ denotes the specific power of the motor drive and its TMS, while $\Pi_{\text{Electric Motor}}$ denotes the specific power of the electric motor and a torque amplifier (if required) and its TMS. The blue shaded area represents the locus of configurations that meet this FOA's specific power requirements. For example, if the system is designed to have a specific power of 20 kW/kg for the electric motor, the associated drive would require a power density of 30 kW/kg to achieve the ASCEND goal of 12 kW/kg for the complete system shown in **Figure 3**. Likewise, a respective example efficiency of 97% for the motor drive and 96% for the electric motor may achieve the ASCEND goal of 93% for the complete system shown in **Figure 3**.

The motor drive should feature a high voltage inverter, as it will be linked to a distribution bus with a rail-to-rail input voltage potential difference of at least 1 kV DC and meet the DO-160 standard³⁴. The electric motor will be integrated with the motor drive and its associated power electronics. The envisioned system must be able to directly drive a propulsor to accelerate air rearwards and create the aircraft thrust. As such, the output rotational speed of the motor should coincide with that of a driven propulsor. For the purpose of this FOA, it is assumed that the propulsor diameter corresponds to that of an existing high bypass-ratio engine with a low fan pressure ratio. As such, the maximum rotational speed is limited to 5,000 RPM. The development of the propulsor itself, however, is outside the system boundary of this FOA.

³⁴ <https://do160.org/rtca-do-160g/>.

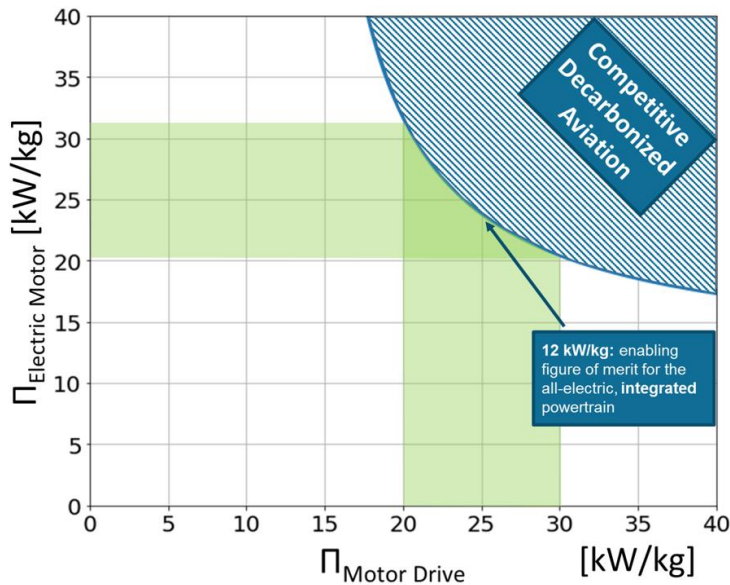

Figure 4: Interrelation between the electric motor (and its torque amplifier, if required, and TMS) specific power and the motor drive (and its TMS) specific power for the all-electric, integrated powertrain with a specific power of 12 kW/kg (blue line).

As mentioned above, the TMS for the electric motor and the motor drive can be a common, shared unit, or by design can be two separate and independently operated TMS's. In each case the proposals should clarify the heat dissipation paths and the respective thermal resistance from the heat source to where the heat is dissipated (i.e. the heat sink) should be estimated and reported in Table 2.a. The coefficient of performance (COP) representing the ratio of the cooling rate over total power consumption by the TMS should also be reported in Table 2.a.

Finally, the specific power of the electric motor and motor drive components should account for the mass of their respective or shared TMS, including the associated coolant weight, as applicable. The metrics for the proposed design should be compared with state-of-the-art and competing solutions. Among other requirements, it is envisioned that the TMS will be closely integrated with the other subsystems to achieve the high-power density required by this FOA. Cryogenic (including superconducting solutions) and non-cryogenic solutions can be considered for this FOA, so long as the FOA's prescribed performance metrics are met.

2. TECHNICAL PERFORMANCE TARGETS

Table 1 provides the technical targets for the **ASCEND** program. For the purpose of this FOA, Applicants can assume sea level environmental conditions of 30°C and one atmosphere for takeoff and climb.

Table 1: Technical targets for the end of the program all-electric powertrain system developmental prototype.

ID	Description	Target
1.1	Takeoff power, mechanical shaft power output	≥ 250 kW
1.2	Maximum rotational speed at takeoff	5,000 RPM
1.3	Takeoff and climb average efficiency. See Eq. (1)	≥ 93%
1.4	Specific power at takeoff and climb	≥ 12 kW/kg
1.5	Cruise power, mechanical shaft power output	≥ 83 kW (1/3 of takeoff power)
1.6	Cruise rotational speed	3,500 RPM – 4,500 RPM
1.7	Average cruise efficiency	≥ 93%
1.8	Rail to rail bus voltage, electrical input	≥ 1 kV DC
1.9	Test compliance	DO-160 ³⁴
1.10	Cost (\$/kW)	≤ 350 @ 5000 units/year
1.11	Mean Time Between Failure (MTBF)	≥ 35,000 hours

Metrics definitions:

Mechanical shaft output power: This is the maximum mechanical power that the system should be capable of delivering during takeoff. The duration of the takeoff and climb power should be consistent with the aircraft flight takeoff profile provided in **Figure 5**.

Maximum rotational speed at takeoff: This is the rotational speed of the shaft after gearbox reduction, if any. It represents the rotational speed of the driven propulsor. The speed is maximum at takeoff and may vary within 70% - 85% of maximum speed at cruise condition.

Takeoff and climb average efficiency: This is the ratio of the average mechanical energy output to average electrical energy input supplied during takeoff and climb. Parasitic loads associated with the TMS should be accounted for in the calculation of efficiency. **Figure 5** provides further details. The average efficiency is defined based on the following equation:

Questions about this FOA? Check the Frequently Asked Questions available at <http://arpa-e.energy.gov/faq>. For questions that have not already been answered, email ARPA-E-CO@hq.doe.gov (with FOA name and number in subject line); see FOA Sec. VII.A. Problems with ARPA-E eXCHANGE? Email ExchangeHelp@hq.doe.gov (with FOA name and number in subject line).

$$\frac{\int_0^{20 \text{ min}} P_{out} dt}{\int_0^{20 \text{ min}} P_{in} dt} \quad (1)$$

Specific power at takeoff and climb: This is the maximum power per unit weight measured in kW/kg. It is computed by normalizing the delivered (at takeoff) mechanical power with the weight of the complete integrated all-electric powertrain system (TMS + electric motor + torque multiplier, if any, + power electronics).

Cruise power, mechanical shaft output: This is the continuous, mechanical power (after torque amplification if necessary) that the all-electric powertrain system should be capable of delivering during the cruise stage. The duration of the cruise power should be consistent with the flight profile provided. Minimum cruise power should be at least equal to one third of the takeoff power of the system. **Figure 5** provides further details.

Cruise efficiency: This is the ratio of the delivered mechanical power (output) to supplied electrical power (input) during cruise. Parasitic loads associated with the TMS should be accounted for in the calculation of efficiency.

Rail to rail bus voltage, electrical input: A high distribution, fault resistant, DC bus is envisioned, with rail to rail voltage potential difference ≥ 1 kV DC as to limit the distribution losses and reduce the weight penalty of the power cables between the power generation system and the electric propulsion system.

Cost: This is the projected cost of the complete system for a production volume of 5,000 units per year. Applicants will provide a high-level Bill of Materials (BOM) for their proposed technology.

Mean Time Between Failure: Mean Time Between Failure (MTBF) of 35,000 hours. For the purpose of this FOA Applicants may propose relevant reliability test descriptions (e.g., accelerated life cycle tests, nondestructive failure tests etc.) to estimate the MTBF. However, detailed reliability metrics are required only in Phase **2** of the project.

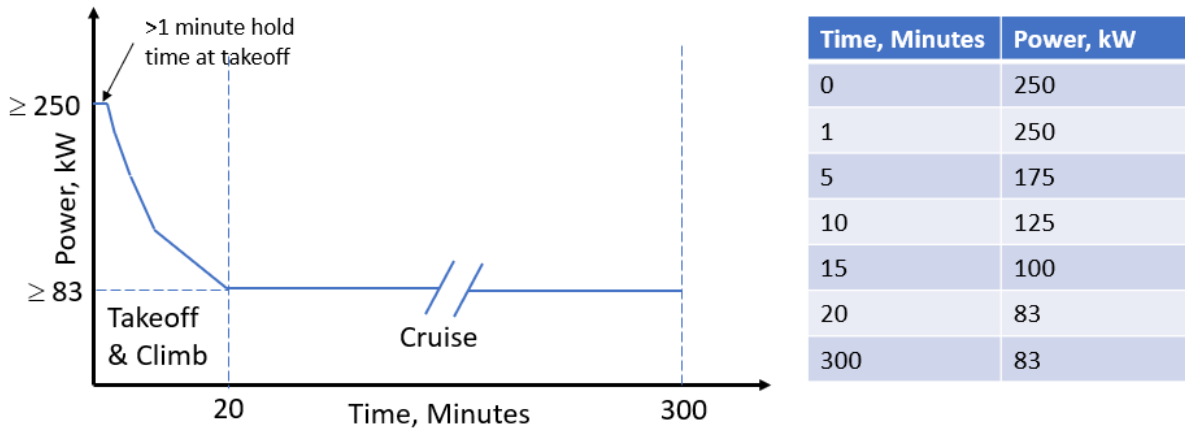

Figure 5: Delivered mechanical power as function of the time flight profile to be used to design the system.

3. PROGRAM STRUCTURE AND DELIVERABLES

ASCEND is a program offered in two separate **programmatic** phases. Applicants must provide detailed budgets and task descriptions that cover both **ASCEND Phase 1** and **ASCEND Phase 2**. Additional details are provided below.

Phase 1. **ASCEND Phase 1** focuses on the conceptual design of the proposed integrated all-electric powertrain system, along with proof-of-concept development and sub-system and component-level testing of key enabling technologies and/or sub-components as necessary to address the associated risks with the proposed solution/technology. **ASCEND Phase 1** will end with a detailed design for the integrated motor and its drive and a validated and clear pathway to achieving the program objectives and the specific performance metrics tabulated in Table 1. **ASCEND Phase 1** can be proposed for a maximum of 18 months, based on the Applicant’s individual assessment and the proposed project’s schedule. All selected projects will initially be provided the funding for **Phase 1** only.

Based on each individual project’s technical success, including meeting technical targets of **ASCEND Phase 1**, ARPA-E may select one or more projects to continue to **ASCEND Phase 2**, subject to the availability of appropriated funds.

Phase 2. During **ASCEND Phase 2**, successful projects will develop a developmental prototype ≥ 250 kW all-electric integrated powertrain which will be then be tested. This final deliverable should be designed for reliable operations at high altitudes (35,000 to 40,000 ft). **Testing of the unit under the conditions of the pressure representative of cruise altitude is required.** The tested ≥ 250 kW-scale all-electric integrated powertrain, must include the electric motor, its drive, TMS, and torque amplifier (if necessary by the proposed design) as represented by the entire block diagram shown in **Figure 3**. Powertrains testing can be accomplished, among other options, using a dynamometer and with loads simulating the flight profile as shown in **Figure 5**.

Questions about this FOA? Check the Frequently Asked Questions available at <http://arpa-e.energy.gov/faq>. For questions that have not already been answered, email ARPA-E-CO@hq.doe.gov (with FOA name and number in subject line); see FOA Sec. VII.A. Problems with ARPA-E eXCHANGE? Email ExchangeHelp@hq.doe.gov (with FOA name and number in subject line).

To that end, applicants should budget for ground level tests that demonstrate basic operational functionality and performance of the all-electric integrated ≥ 250 kW powertrain. For projects that have successfully passed the ground level test conditions, ARPA-E, subject to the availability of appropriated funds, plans to designate a testing site(s) for subsequent testing of the all-electric integrated ≥ 250 kW powertrain at simulated altitude conditions. Accordingly, applicants should not budget for such simulated altitude testing. ASCEND Phase 2 can be proposed for a maximum of 24 months.

To facilitate clear description of the technology solutions in each of the subsystems, their integration and specific metrics to be achieved, **Applicants are required to provide the information in the following two tables (2.a and 2.b) and include in their submission.**

Table 2.a: Proposal summary to be provided by ASCEND Applicants and included in their submission.

System	Requirement	Proposed Metric
Overall system: All-electric Integrated Powertrain	Input Voltage - V_{in} (≥ 1 kV) DC	
	System capacity (≥ 250 kW)	
	Takeoff and climb average efficiency per Eq. (1) for the complete powertrain (motor, drive, and TMS), %	
	Cruise average efficiency for the complete powertrain (motor, drive, and TMS), %	
	Power density at takeoff for the complete powertrain (motor, drive, and TMS), mass based, [kW/kg]	
	Power density at takeoff for the complete powertrain (motor, drive, and TMS), volume based, [kW/L]	
	Projected cost at 5,000 units/year for the complete powertrain (motor, drive, and TMS), [\$/kW]	
Subsystem: Motor Drive (including TMS)	Brief description (2-3 lines) of the utilized TMS technology	
	TMS average C.O.P. ³⁵ at takeoff and climb condition	
	TMS average C.O.P.³⁵ at cruise condition	
	Brief description (2-3 lines) of the Motor drive technology	
	Takeoff and climb average efficiency per Eq. (1), %	

³⁵ Coefficient of Performance (C.O.P.): This is the ratio of heat rejection rate per input power to the TMS. There are two COP values of interest. One at **takeoff and climb** condition and **the other one** at constant power (cruise) condition.

	Cruise average efficiency, %	
	Estimated overall thermal resistance, [K/W]	
	Power density (including TMS) at takeoff, [kW/kg]	
Subsystem: Electric Motor (including TMS and torque amplifier, if any)	Brief description (2-3 lines) of the utilized TMS technology	
	TMS average C.O.P. ³⁵ at takeoff and climb condition	
	TMS average C.O.P. ³⁵ at cruise condition	
	Brief description (2-3 lines) of the Electric motor technology	
	Takeoff and climb average efficiency per Eq. (1), %	
	Cruise average efficiency, %	
	Takeoff rotational speed of the motor, [RPM]	
	Estimated overall thermal resistance, [K/W]	
	Power density (including TMS) at takeoff, [kW/kg]; Does your design feature a torque amplifier? [Yes/No]	

Table 2.b: List of key enabling technologies and their projected respective contribution to achieving the targeted metrics for power density and efficiency (integrated motor and drive), to be provided by ASCEND Applicants and included in their submission.

Key enabling technologies	Projected factor of improvement over state-of-the-art	
	Power density	Efficiency
Advanced winding/motor design		
Advanced insulation materials		
Advanced cooling technologies		
Advanced structural materials		
Co-design & optimum integration		
Other 1		
Other 2		
"....."		

Questions about this FOA? Check the Frequently Asked Questions available at <http://arpa-e.energy.gov/faq>. For questions that have not already been answered, email ARPA-E-CO@hq.doe.gov (with FOA name and number in subject line); see FOA Sec. VII.A. Problems with ARPA-E eXCHANGE? Email ExchangeHelp@hq.doe.gov (with FOA name and number in subject line).

II. AWARD INFORMATION

A. AWARD OVERVIEW

ARPA-E expects to make approximately \$35 million available for new awards, to be shared between FOAs DE-FOA-0002238 and DE-FOA-0002239, subject to the availability of appropriated funds. ARPA-E anticipates making approximately 8-12 awards under FOAs DE-FOA-0002238 and DE-FOA-0002239. ARPA-E may, at its discretion, issue one, multiple, or no awards.

Individual awards may vary between \$250,000 and \$10 million.

The period of performance for funding agreements may not exceed 42 months for Phase 1 and Phase 2 combined. ARPA-E expects the start date for funding agreements to be November 2020, or as negotiated.

ARPA-E encourages submissions stemming from ideas that still require proof-of-concept R&D efforts as well as those for which some proof-of-concept demonstration already exists.

Submissions requiring proof-of-concept R&D can propose a project with the goal of delivering on the program metric at the conclusion of the period of performance. These submissions must contain an appropriate cost and project duration plan that is described in sufficient technical detail to allow reviewers to meaningfully evaluate the proposed project. If awarded, such projects should expect a rigorous go/no-go milestone early in the project associated with the proof-of-concept demonstration. Alternatively, submissions requiring proof-of-concept R&D can propose a project with the project end deliverable being an extremely creative, but partial solution. However, the Applicants are required to provide a convincing vision how these partial solutions can enable the realization of the program metrics with further development.

Applicants proposing projects for which some initial proof-of-concept demonstration already exists should submit concrete data that supports the probability of success of the proposed project.

ARPA-E will provide support at the highest funding level only for submissions with significant technology risk, aggressive timetables, and careful management and mitigation of the associated risks.

ARPA-E will accept only new submissions under this FOA. Applicants may not seek renewal or supplementation of their existing awards through this FOA.

ARPA-E plans to fully fund your negotiated budget at the time of award.

Questions about this FOA? Check the Frequently Asked Questions available at <http://arpa-e.energy.gov/faq>. For questions that have not already been answered, email ARPA-E-CO@hq.doe.gov (with FOA name and number in subject line); see FOA Sec. VII.A. Problems with ARPA-E eXCHANGE? Email ExchangeHelp@hq.doe.gov (with FOA name and number in subject line).

B. RENEWAL AWARDS

At ARPA-E's sole discretion, awards resulting from this FOA may be renewed by adding one or more budget periods, extending the period of performance of the initial award, or issuing new award. Renewal funding is contingent on: (1) availability of funds appropriated by Congress for the purpose of this program; (2) substantial progress towards meeting the objectives of the approved application; (3) submittal of required reports; (4) compliance with the terms and conditions of the award; (5) ARPA-E approval of a renewal application; and (6) other factors identified by the Agency at the time it solicits a renewal application.

C. ARPA-E FUNDING AGREEMENTS

Through cooperative agreements, other transactions, and similar agreements, ARPA-E provides financial and other support to projects that have the potential to realize ARPA-E's statutory mission. ARPA-E does not use such agreements to acquire property or services for the direct benefit or use of the U.S. Government.

Congress directed ARPA-E to "establish and monitor project milestones, initiate research projects quickly, and just as quickly terminate or restructure projects if such milestones are not achieved."³⁶ Accordingly, ARPA-E has substantial involvement in the direction of every Cooperative Agreement, as described in Section II.D below.

1. COOPERATIVE AGREEMENTS

ARPA-E generally uses Cooperative Agreements to provide financial and other support to Prime Recipients.³⁷

Cooperative Agreements involve the provision of financial or other support to accomplish a public purpose of support or stimulation authorized by Federal statute. Under Cooperative Agreements, the Government and Prime Recipients share responsibility for the direction of projects.

ARPA-E encourages Prime Recipients to review the Model Cooperative Agreement, which is available at <http://arpa-e.energy.gov/arpa-e-site-page/award-guidance>.

2. FUNDING AGREEMENTS WITH FFRDCs/DOE LABS, GOGOs, AND FEDERAL INSTRUMENTALITIES

Any Federally Funded Research and Development Centers (FFRDC) involved as a member of a Project Team must provide the information requested in the "FFRDC Lab Authorization" and

³⁶ U.S. Congress, Conference Report to accompany the 21st Century Competitiveness Act of 2007, H. Rpt. 110-289 at 171-172 (Aug. 1, 2007).

³⁷ The Prime Recipient is the signatory to the funding agreement with ARPA-E.

“Field Work Proposal” section of the Business Assurances & Disclosures Form, which is submitted with the Applicant’s Full Application.

When a FFRDC/DOE Lab (including the National Energy Technology Laboratory or NETL) is the *lead organization* for a Project Team, ARPA-E executes a funding agreement directly with the FFRDC/DOE Lab and a single, separate Cooperative Agreement with the rest of the Project Team. Notwithstanding the use of multiple agreements, the FFRDC/DOE Lab is the lead organization for the entire project, including all work performed by the FFRDC/DOE Lab and the rest of the Project Team.

When a FFRDC/DOE Lab is a *member* of a Project Team, ARPA-E executes a funding agreement directly with the FFRDC/DOE Lab and a single, separate Cooperative Agreement with the rest of the Project Team. Notwithstanding the use of multiple agreements, the Prime Recipient under the Cooperative Agreement is the lead organization for the entire project, including all work performed by the FFRDC/DOE Lab and the rest of the Project Team.

Funding agreements with DOE/NNSA FFRDCs take the form of Work Authorizations issued to DOE/NNSA FFRDCs through the DOE/NNSA Field Work Proposal system for work performed under Department of Energy Management & Operation Contracts. Funding agreements with non-DOE/NNSA FFRDCs, GOGOs (including NETL), and Federal instrumentalities (e.g., Tennessee Valley Authority) will be consistent with the sponsoring agreement between the U.S. Government and the Laboratory. Any funding agreement with a FFRDC or GOGO will have similar terms and conditions as ARPA-E’s Model Cooperative Agreement (<https://arpa-e.energy.gov/?q=site-page/funding-agreements>).

Non-DOE GOGOs and Federal agencies may be proposed to provide support to the project team members on an applicant’s project, through a Cooperative Research and Development Agreement (CRADA) or similar agreement.

3. OTHER TRANSACTIONS AUTHORITY

ARPA-E may use its “other transactions” authority under the America COMPETES Reauthorization Act of 2010 to enter into an other transaction agreement with Prime Recipients, on a case-by-case basis.

ARPA-E may negotiate an other transaction agreement when it determines that the use of a standard cooperative agreement, grant, or contract is not feasible or appropriate for a project.

In general, an other transaction agreement would require a cost share of 50%. See Section III.B.2 of the FOA.

D. STATEMENT OF SUBSTANTIAL INVOLVEMENT

ARPA-E is substantially involved in the direction of projects from inception to completion. For the purposes of an ARPA-E project, substantial involvement means:

- Project Teams must adhere to ARPA-E’s agency-specific and programmatic requirements.
- ARPA-E may intervene at any time in the conduct or performance of work under an award.
- ARPA-E does not limit its involvement to the administrative requirements of an award. Instead, ARPA-E has substantial involvement in the direction and redirection of the technical aspects of the project as a whole.
- ARPA-E may, at its sole discretion, modify or terminate projects that fail to achieve predetermined Go/No Go decision points or technical milestones and deliverables.
- During award negotiations, ARPA-E Program Directors and Prime Recipients mutually establish an aggressive schedule of quantitative milestones and deliverables that must be met every quarter. In addition, ARPA-E will negotiate and establish “Go/No-Go” milestones for each project. If the Prime Recipient fails to achieve any of the “Go/No-Go” milestones or technical milestones and deliverables as determined by the ARPA-E Contracting Officer, ARPA-E may – at its discretion - renegotiate the statement of project objectives or schedule of technical milestones and deliverables for the project. In the alternative, ARPA-E may suspend or terminate the award in accordance with 2 C.F.R. §§ 200.338 and 200.339.
- ARPA-E may provide guidance and/or assistance to the Prime Recipient to accelerate the commercial deployment of ARPA-E-funded technologies. Guidance and assistance provided by ARPA-E may include coordination with other Government agencies and nonprofits to provide mentoring and networking opportunities for Prime Recipients. ARPA-E may also organize and sponsor events to educate Prime Recipients about key barriers to the deployment of their ARPA-E-funded technologies. In addition, ARPA-E may establish collaborations with private and public entities to provide continued support for the development and deployment of ARPA-E-funded technologies.

Questions about this FOA? Check the Frequently Asked Questions available at <http://arpa-e.energy.gov/faq>. For questions that have not already been answered, email ARPA-E-CO@hq.doe.gov (with FOA name and number in subject line); see FOA Sec. VII.A. Problems with ARPA-E eXCHANGE? Email ExchangeHelp@hq.doe.gov (with FOA name and number in subject line).

III. ELIGIBILITY INFORMATION

A. ELIGIBLE APPLICANTS

This FOA is open to U.S. universities, national laboratories, industry and individuals.

1. INDIVIDUALS

U.S. citizens or permanent residents may apply for funding in their individual capacity as a Standalone Applicant,³⁸ as the lead for a Project Team,³⁹ or as a member of a Project Team. However, ARPA-E will only award funding to an entity formed by the Applicant.

2. DOMESTIC ENTITIES

For-profit entities, educational institutions, and nonprofits⁴⁰ that are incorporated in the United States, including U.S. territories, are eligible to apply for funding as a Standalone Applicant, as the lead organization for a Project Team, or as a member of a Project Team.

FFRDCs/DOE Labs are eligible to apply for funding as the lead organization for a Project Team or as a member of a Project Team that includes institutions of higher education, companies, research foundations, or trade and industry research collaborations, but not as a Standalone Applicant.

State, local, and tribal government entities are eligible to apply for funding as a member of a Project Team, but not as a Standalone Applicant or as the lead organization for a Project Team.

Federal agencies and instrumentalities (other than DOE) are eligible to apply for funding as a member of a Project Team, but not as a Standalone Applicant or as the lead organization for a Project Team.

3. FOREIGN ENTITIES

Foreign entities, whether for-profit or otherwise, are eligible to apply for funding as Standalone Applicants, as the lead organization for a Project Team, or as a member of a Project Team. Foreign entities must designate in the Full Application a subsidiary or affiliate incorporated (or otherwise formed or to be formed) under the laws of a State or territory of the United States to

³⁸ A Standalone Applicant is an Applicant that applies for funding on its own, not as part of a Project Team.

³⁹ A Project Team consists of the Prime Recipient, Subrecipients, and others performing any of the research and development work under an ARPA-E funding agreement, whether or not costs of performing the research and development work are being reimbursed under any agreement.

⁴⁰ Nonprofit organizations described in section 501(c)(4) of the Internal Revenue Code of 1986 that engaged in lobbying activities after December 31, 1995 are not eligible to apply for funding as a Prime Recipient or Subrecipient.

receive funding. The Full Application must state the nature of the corporate relationship between the foreign entity and domestic subsidiary or affiliate. All work under the ARPA-E award must be performed in the United States. The Applicant may request a waiver of this requirement in the Business Assurances & Disclosures Form, which is submitted with the Full Application and can be found at <https://arpa-e-foa.energy.gov/>. Refer to the Business Assurances & Disclosures Form for guidance on the content and form of the request.

4. CONSORTIUM ENTITIES

Consortia, which may include domestic and foreign entities, must designate one member of the consortium as the consortium representative to the Project Team. The consortium representative must be incorporated in the United States. The eligibility of the consortium will be determined by reference to the eligibility of the consortium representative under Section III.A of the FOA. Each consortium must have an internal governance structure and a written set of internal rules. Upon request, the consortium entity must provide a written description of its internal governance structure and its internal rules to the Contracting Officer (ARPA-E-CO@hq.doe.gov).

Unincorporated consortia must provide the Contracting Officer with a collaboration agreement, commonly referred to as the articles of collaboration, which sets out the rights and responsibilities of each consortium member. This collaboration agreement binds the individual consortium members together and shall include the consortium's:

- Management structure;
- Method of making payments to consortium members;
- Means of ensuring and overseeing members' efforts on the project;
- Provisions for members' cost sharing contributions; and
- Provisions for ownership and rights in intellectual property developed previously or under the agreement.

B. COST SHARING⁴¹

Applicants are bound by the cost share proposed in their Full Applications.

⁴¹ Please refer to Section VI.B.3-4 of the FOA for guidance on cost share payments and reporting.

1. BASE COST SHARE REQUIREMENT

ARPA-E generally uses Cooperative Agreements to provide financial and other support to Prime Recipients (see Section II.C.1 of the FOA). Under a Cooperative Agreement or Grant, the Prime Recipient must provide at least 20% of the Total Project Cost⁴² as cost share, except as provided in Sections III.B.2 or III.B.3 below.⁴³

2. INCREASED COST SHARE REQUIREMENT

Large businesses are strongly encouraged to provide more than 20% of the Total Project Cost as cost share. ARPA-E may consider the amount of cost share proposed when selecting applications for award negotiations (see Section V.B.1 of the FOA).

Under an “other transaction” agreement, the Prime Recipient must provide at least 50% of the Total Project Cost as cost share. ARPA-E may reduce this cost share requirement, as appropriate.

3. REDUCED COST SHARE REQUIREMENT

ARPA-E has reduced the base cost share requirement for the following types of projects:

- A domestic educational institution or domestic nonprofit applying as a Standalone Applicant is not required to provide cost share.
- Project Teams composed exclusively of domestic educational institutions, domestic nonprofits, and/or FFRDCs/DOE Labs/Federal agencies and instrumentalities (other than DOE) are not required to provide cost share.
- Small businesses – or consortia of small businesses – may provide 0% cost share from the outset of the project through the first 12 months of the project (hereinafter the “Cost Share Grace Period”).⁴⁴ If the project is continued beyond the Cost Share Grace Period, then at least 10% of the Total Project Cost (including the costs incurred during the Cost Share Grace Period) will be required as cost share over the remaining period of performance.
- Project Teams where a small business is the lead organization and small businesses perform greater than or equal to 80% of the total work under the funding

⁴² The Total Project Cost is the sum of the Prime Recipient share and the Federal Government share of total allowable costs. The Federal Government share generally includes costs incurred by GOGOs and FFRDCs.

⁴³ Energy Policy Act of 2005, Pub.L. 109-58, sec. 988.

⁴⁴ Small businesses are generally defined as domestically incorporated entities that meet the criteria established by the U.S. Small Business Administration’s (SBA) “Table of Small Business Size Standards Matched to North American Industry Classification System Codes” (NAICS) (<http://www.sba.gov/content/small-business-size-standards>). Applicants that are small businesses will be required to certify in the Business Assurances & Disclosures Form that their organization meets the SBA’s definition of a small business under at least one NAICS code.

agreement (as measured by the Total Project Cost) are entitled to the same cost share reduction and Cost Share Grace Period as provided above to Standalone small businesses or consortia of small businesses.⁴⁵

- Project Teams where domestic educational institutions, domestic nonprofits, small businesses, and/or FFRDCs perform greater than or equal to 80% of the total work under the funding agreement (as measured by the Total Project Cost) are required to provide at least 10% of the Total Project Cost as cost share. However, any entity (such as a large business) receiving patent rights under a class waiver, or other patent waiver, that is part of a Project Team receiving this reduction must continue to meet the statutory minimum cost share requirement (20%) for its portion of the Total Project Cost.
- Projects that do not meet any of the above criteria are subject to the base cost share requirements described in Sections III.B.1 and III.B.2 of the FOA.

4. LEGAL RESPONSIBILITY

Although the cost share requirement applies to the Project Team as a whole, the funding agreement makes the Prime Recipient legally responsible for paying, or ensuring payment of, the entire cost share. The Prime Recipient's cost share obligation is expressed in the funding agreement as a static amount in U.S. dollars (cost share amount) and as a percentage of the Total Project Cost (cost share percentage). If the funding agreement is terminated prior to the end of the period of performance, the Prime Recipient is required to contribute at least the cost share percentage of total expenditures incurred through the date of termination.

The Prime Recipient is solely responsible for managing cost share contributions by the Project Team and enforcing cost share obligations assumed by Project Team members in subawards or related agreements.

5. COST SHARE ALLOCATION

Each Project Team is free to determine how much each Project Team member will contribute towards the cost share requirement. The amount contributed by individual Project Team members may vary, as long as the cost share requirement for the project as a whole is met.

6. COST SHARE TYPES AND ALLOWABILITY

Every cost share contribution must be allowable under the applicable Federal cost principles, as described in Section IV.G of the FOA.

Project Teams may provide cost share in the form of cash or in-kind contributions. Cash contributions may be provided by the Prime Recipient or Subrecipients. Allowable in-kind

⁴⁵ See the information provided in previous footnote.

contributions include but are not limited to personnel costs, indirect costs, facilities and administrative costs, rental value of buildings or equipment, and the value of a service, other resource, or third party in-kind contribution. Project Teams may use funding or property received from state or local governments to meet the cost share requirement, so long as the funding or property was not provided to the state or local government by the Federal Government.

The Prime Recipient may not use the following sources to meet its cost share obligations:

- Revenues or royalties from the prospective operation of an activity beyond the period of performance;
- Proceeds from the prospective sale of an asset of an activity;
- Federal funding or property (e.g., Federal grants, equipment owned by the Federal Government); or
- Expenditures that were reimbursed under a separate Federal program.

In addition, Project Teams may not use independent research and development (IR&D) funds⁴⁶ to meet their cost share obligations under Cooperative Agreements. However, Project Teams may use IR&D funds to meet their cost share obligations under “other transaction” agreements.

Project Teams may not use the same cash or in-kind contributions to meet cost share requirements for more than one project or program.

Cost share contributions must be specified in the project budget, verifiable from the Prime Recipient’s records, and necessary and reasonable for proper and efficient accomplishment of the project. Every cost share contribution must be reviewed and approved in advance by the Contracting Officer and incorporated into the project budget before the expenditures are incurred.

Applicants may wish to refer to 2 C.F.R. Parts 200 and 910, and 10 C.F.R Part 603 for additional guidance on cost sharing, specifically 2 C.F.R. §§ 200.306 and 910.130, and 10 C.F.R. §§ 603.525-555.

7. COST SHARE CONTRIBUTIONS BY FFRDCs AND GOGOS

Because FFRDCs are funded by the Federal Government, costs incurred by FFRDCs generally may not be used to meet the cost share requirement. FFRDCs may contribute cost share only if the contributions are paid directly from the contractor’s Management Fee or a non-Federal source.

Because GOGOs/Federal Agencies are funded by the Federal Government, GOGOs/Federal Agencies may not provide cost share for the proposed project. However, the GOGO/Agency

⁴⁶ As defined in Federal Acquisition Regulation SubSection 31.205-18.

costs would be included in Total Project Costs for purposes of calculating the cost-sharing requirements of the applicant.

8. COST SHARE VERIFICATION

Upon selection for award negotiations, Applicants are required to provide information and documentation regarding their cost share contributions. Please refer to Section VI.B of the FOA for guidance on the requisite cost share information and documentation.

C. OTHER

1. COMPLIANT CRITERIA

Concept Papers are deemed compliant if:

- The Applicant meets the eligibility requirements in Section III.A of the FOA;
- The Concept Paper complies with the content and form requirements in Section IV.C of the FOA; and
- The Applicant entered all required information, successfully uploaded all required documents, and clicked the “Submit” button in ARPA-E eXCHANGE by the deadline stated in the FOA.

Concept Papers found to be noncompliant may not be merit reviewed or considered for award. ARPA-E may not review or consider noncompliant Concept Papers, including Concept Papers submitted through other means, Concept Papers submitted after the applicable deadline, and incomplete Concept Papers. A Concept Paper is incomplete if it does not include required information. ARPA-E will not extend the submission deadline for Applicants that fail to submit required information and documents due to server/connection congestion.

Full Applications are deemed compliant if:

- The Applicant submitted a compliant and responsive Concept Paper;
- The Applicant meets the eligibility requirements in Section III.A of the FOA;
- The Full Application complies with the content and form requirements in Section IV.D of the FOA; and
- The Applicant entered all required information, successfully uploaded all required documents, and clicked the “Submit” button in ARPA-E eXCHANGE by the deadline stated in the FOA.

Full Applications found to be noncompliant may not be merit reviewed or considered for award. ARPA-E may not review or consider noncompliant Full Applications, including Full Applications submitted through other means, Full Applications submitted after the applicable deadline, and incomplete Full Applications. A Full Application is incomplete if it does not

include required information and documents, such as Forms SF-424 and SF-424A. ARPA-E will not extend the submission deadline for Applicants that fail to submit required information and documents due to server/connection congestion.

Replies to Reviewer Comments are deemed compliant if:

- The Applicant successfully uploads its response to ARPA-E eXCHANGE by the deadline stated in the FOA; and
- The Replies to Reviewer Comments comply with the content and form requirements of Section IV.E of the FOA.

ARPA-E will not review or consider noncompliant Replies to Reviewer Comments, including Replies submitted through other means and Replies submitted after the applicable deadline. ARPA-E will not extend the submission deadline for Applicants that fail to submit required information due to server/connection congestion. ARPA-E will review and consider each compliant and responsive Full Application, even if no Reply is submitted or if the Reply is found to be noncompliant.

2. RESPONSIVENESS CRITERIA

ARPA-E performs a preliminary technical review of Concept Papers and Full Applications. The following types of submissions may be deemed nonresponsive and may not be reviewed or considered:

- Submissions that fall outside the technical parameters specified in this FOA.
- Submissions that have been submitted in response to currently issued ARPA-E FOAs.
- Submissions that are not scientifically distinct from applications submitted in response to currently issued ARPA-E FOAs.
- Submissions for basic research aimed solely at discovery and/or fundamental knowledge generation.
- Submissions for large-scale demonstration projects of existing technologies.
- Submissions for proposed technologies that represent incremental improvements to existing technologies.
- Submissions for proposed technologies that are not based on sound scientific principles (e.g., violates a law of thermodynamics).
- Submissions for proposed technologies that are not transformational, as described in Section I.A of the FOA.
- Submissions for proposed technologies that do not have the potential to become disruptive in nature, as described in Section I.A of the FOA. Technologies must be scalable such that they could be disruptive with sufficient technical progress.
- Submissions that are not distinct in scientific approach or objective from activities currently supported by or actively under consideration for funding by any other office within Department of Energy.

Questions about this FOA? Check the Frequently Asked Questions available at <http://arpa-e.energy.gov/faq>. For questions that have not already been answered, email ARPA-E-CO@hq.doe.gov (with FOA name and number in subject line); see FOA Sec. VII.A. Problems with ARPA-E eXCHANGE? Email ExchangeHelp@hq.doe.gov (with FOA name and number in subject line).

- Submissions that are not distinct in scientific approach or objective from activities currently supported by or actively under consideration for funding by other government agencies or the private sector.
- Submissions that do not propose a R&D plan that allows ARPA-E to evaluate the submission under the applicable merit review criteria provided in Section V.A of the FOA.

3. SUBMISSIONS SPECIFICALLY NOT OF INTEREST

Submissions that propose the following will be deemed nonresponsive and will not be merit reviewed or considered:

- Electric motors, thermal management systems or power electronics development alone without integration into the targeted system or sub-system(s).
- Software development alone.
- Paper studies alone.
- Materials development alone without integration into the targeted system or sub-system(s).
- Systems that will not be suitable for deployment into narrow-body aircraft of the type described and which will not meet the flight envelope requirements in speed and altitude, for example.

4. LIMITATION ON NUMBER OF SUBMISSIONS

ARPA-E is not limiting the number of submissions from Applicants. Applicants may submit more than one application to this FOA, provided that each application is scientifically distinct.

IV. APPLICATION AND SUBMISSION INFORMATION

A. APPLICATION PROCESS OVERVIEW

1. REGISTRATION IN ARPA-E eXCHANGE

The first step in applying to this FOA is registration in ARPA-E eXCHANGE, ARPA-E's online application portal. For detailed guidance on using ARPA-E eXCHANGE, please refer to Section IV.H.1 of the FOA and the "ARPA-E eXCHANGE User Guide" (<https://arpa-e-foa.energy.gov/Manuals.aspx>).

2. CONCEPT PAPERS

Applicants must submit a Concept Paper by the deadline stated in the FOA. Section IV.C of the FOA provides instructions on submitting a Concept Paper.

ARPA-E performs a preliminary review of Concept Papers to determine whether they are compliant and responsive, as described in Section III.C of the FOA. Concept Papers found to be noncompliant or nonresponsive may not be merit reviewed or considered for award. ARPA-E makes an independent assessment of each compliant and responsive Concept Paper based on the criteria and program policy factors in Sections V.A.1 and V.B.1 of the FOA.

ARPA-E will encourage a subset of Applicants to submit Full Applications. Other Applicants will be discouraged from submitting a Full Application in order to save them the time and expense of preparing an application submission that is unlikely to be selected for award negotiations. By discouraging the submission of a Full Application, ARPA-E intends to convey its lack of programmatic interest in the proposed project. Such assessments do not necessarily reflect judgments on the merits of the proposed project. Unsuccessful Applicants should continue to submit innovative ideas and concepts to future FOAs.

3. FULL APPLICATIONS

Applicants must submit a Full Application by the deadline stated in the FOA. Applicants will have approximately 60 45 days from receipt of the Encourage/Discourage notification to prepare and submit a Full Application. Section IV.D of the FOA provides instructions on submitting a Full Application.

ARPA-E performs a preliminary review of Full Applications to determine whether they are compliant and responsive, as described in Section III.C of the FOA. Full Applications found to be noncompliant or nonresponsive may not be merit reviewed or considered for award. ARPA-E makes an independent assessment of each compliant and responsive Full Application based on the criteria and program policy factors in Sections V.A.2 and V.B.1 of the FOA.

Questions about this FOA? Check the Frequently Asked Questions available at <http://arpa-e.energy.gov/faq>. For questions that have not already been answered, email ARPA-E-CO@hq.doe.gov (with FOA name and number in subject line); see FOA Sec. VII.A. Problems with ARPA-E eXCHANGE? Email ExchangeHelp@hq.doe.gov (with FOA name and number in subject line).

4. REPLY TO REVIEWER COMMENTS

Once ARPA-E has completed its review of Full Applications, reviewer comments on compliant and responsive Full Applications are made available to Applicants via ARPA-E eXCHANGE. Applicants may submit an optional Reply to Reviewer Comments, which must be submitted by the deadline stated in the FOA. Section IV.E of the FOA provides instructions on submitting a Reply to Reviewer Comments.

ARPA-E performs a preliminary review of Replies to determine whether they are compliant, as described in Section III.C.1 of the FOA. ARPA-E will review and consider compliant Replies only. ARPA-E will review and consider each compliant and responsive Full Application, even if no Reply is submitted or if the Reply is found to be non-compliant.

5. PRE-SELECTION CLARIFICATIONS AND “DOWN-SELECT” PROCESS

Once ARPA-E completes its review of Full Applications and Replies to Reviewer Comments, it may, at the Contracting Officer’s discretion, conduct a pre-selection clarification process and/or perform a “down-select” of Full Applications. Through the pre-selection clarification process or down-select process, ARPA-E may obtain additional information from select Applicants through pre-selection meetings, webinars, videoconferences, conference calls, written correspondence, or site visits that can be used to make a final selection determination. ARPA-E will not reimburse Applicants for travel and other expenses relating to pre-selection meetings or site visits, nor will these costs be eligible for reimbursement as pre-award costs.

ARPA-E may select applications for award negotiations and make awards without pre-selection meetings and site visits. Participation in a pre-selection meeting or site visit with ARPA-E does not signify that Applicants have been selected for award negotiations.

6. SELECTION FOR AWARD NEGOTIATIONS

ARPA-E carefully considers all of the information obtained through the application process and makes an independent assessment of each compliant and responsive Full Application based on the criteria and program policy factors in Sections V.A.2 and V.B.1 of the FOA. The Selection Official may select all or part of a Full Application for award negotiations. The Selection Official may also postpone a final selection determination on one or more Full Applications until a later date, subject to availability of funds and other factors. ARPA-E will enter into award negotiations only with selected Applicants.

Applicants are promptly notified of ARPA-E’s selection determination. ARPA-E may stagger its selection determinations. As a result, some Applicants may receive their notification letter in advance of other Applicants. Please refer to Section VI.A of the FOA for guidance on award notifications.

B. APPLICATION FORMS

Required forms for Full Applications are available on ARPA-E eXCHANGE (<https://arpa-e-foa.energy.gov>), including the SF-424 and Budget Justification Workbook/SF-424A. A sample Summary Slide is available on ARPA-E eXCHANGE. Applicants may use the templates available on ARPA-E eXCHANGE, including the template for the Concept Paper, the template for the Technical Volume of the Full Application, the template for the Summary Slide, the template for the Summary for Public Release, the template for the Reply to Reviewer Comments, and the template for the Business Assurances & Disclosures Form. A sample response to the Business Assurances & Disclosures Form is available on ARPA-E eXCHANGE.

C. CONTENT AND FORM OF CONCEPT PAPERS

The Concept Paper is mandatory (i.e. in order to submit a Full Application, a compliant and responsive Concept Paper must have been submitted) and must conform to the following formatting requirements:

- The Concept Paper must not exceed 4 pages in length including graphics, figures, and/or tables (except Tables 2.a & 2.b, provided as Tables 2.a & 2.b in the Concept Paper Template, which will not count as part of the 4 pages and must not exceed 2 pages.)
- The Concept Paper must be submitted in Adobe PDF format.
- The Concept Paper must be written in English.
- All pages must be formatted to fit on 8-1/2 by 11 inch paper with margins not less than one inch on every side. Single space all text and use Times New Roman typeface, a black font color, and a font size of 12 point or larger (except in figures and tables).
- The ARPA-E assigned Control Number, the Lead Organization Name, and the Principal Investigator's Last Name must be prominently displayed on the upper right corner of the header of every page. Page numbers must be included in the footer of every page.
- The first paragraph must include the Lead Organization's Name and Location, Principal Investigator's Name, Technical Category, Proposed Funding Requested (Federal and Cost Share), and Project Duration.

Concept Papers found to be noncompliant or nonresponsive may not be merit reviewed or considered for award (see Section III.C of the FOA).

Each Concept Paper must be limited to a single concept or technology. Unrelated concepts and technologies must not be consolidated into a single Concept Paper.

A fillable Concept Paper template is available on ARPA-E eXCHANGE at <https://arpa-e-foa.energy.gov>.

Questions about this FOA? Check the Frequently Asked Questions available at <http://arpa-e.energy.gov/faq>. For questions that have not already been answered, email ARPA-E-CO@hq.doe.gov (with FOA name and number in subject line); see FOA Sec. VII.A. Problems with ARPA-E eXCHANGE? Email ExchangeHelp@hq.doe.gov (with FOA name and number in subject line).

Concept Papers must conform to the content requirements described below. If Applicants exceed the maximum page length indicated above, ARPA-E will review only the authorized number of pages and disregard any additional pages.

1. CONCEPT PAPER

a. CONCEPT SUMMARY

- Describe the proposed concept with minimal jargon, and explain how it addresses the Program Objectives of the FOA.

b. INNOVATION AND IMPACT

- Clearly identify the problem to be solved with the proposed technology concept.
- Describe how the proposed effort represents an innovative and potentially transformational solution to the technical challenges posed by the FOA.
- Explain the concept's potential to be disruptive compared to existing or emerging technologies.
- To the extent possible, provide quantitative metrics in a table that compares the proposed technology concept to current and emerging technologies and to the Technical Performance Targets in Section I.D of the FOA.
- Provide estimated quantitative performance metrics. Applicants may use Tables 2.a & 2.b provided at the end of the Concept Paper template. All information requested in Tables 2.a & 2.b must be provided.

c. PROPOSED WORK

- Describe the final deliverable(s) for the project and the overall technical approach used to achieve project objectives.
- Discuss alternative approaches considered, if any, and why the proposed approach is most appropriate for the project objectives.
- Describe the background, theory, simulation, modeling, experimental data, or other sound engineering and scientific practices or principles that support the proposed approach. Provide specific examples of supporting data and/or appropriate citations to the scientific and technical literature.
- Describe why the proposed effort is a significant technical challenge and the key technical risks to the project. Does the approach require one or more entirely new technical developments to succeed? How will technical risk be mitigated?
- Identify techno-economic challenges to be overcome for the proposed technology to be commercially relevant.
- Estimated federal funds requested; total project cost including cost sharing.

Questions about this FOA? Check the Frequently Asked Questions available at <http://arpa-e.energy.gov/faq>. For questions that have not already been answered, email ARPA-E-CO@hq.doe.gov (with FOA name and number in subject line); see FOA Sec. VII.A. Problems with ARPA-E eXCHANGE? Email ExchangeHelp@hq.doe.gov (with FOA name and number in subject line).

d. TEAM ORGANIZATION AND CAPABILITIES

- Indicate the roles and responsibilities of the organizations and key personnel that comprise the Project Team.
- Provide the name, position, and institution of each key team member and describe in 1-2 sentences the skills and experience that he/she brings to the team.
- Identify key capabilities provided by the organizations comprising the Project Team and how those key capabilities will be used in the proposed effort.
- Identify (if applicable) previous collaborative efforts among team members relevant to the proposed effort.

D. CONTENT AND FORM OF FULL APPLICATIONS

Full Applications must conform to the following formatting requirements:

- Each document must be submitted in the file format prescribed below.
- The Full Application must be written in English.
- All pages must be formatted to fit on 8-1/2 by 11 inch paper with margins not less than one inch on every side. Single space all text and use Times New Roman typeface, a black font color, and a font size of 12 point or larger (except in figures and tables).
- The ARPA-E assigned Control Number, the Lead Organization Name, and the Principal Investigator’s Last Name must be prominently displayed on the upper right corner of the header of every page. Page numbers must be included in the footer of every page.

Full Applications found to be noncompliant or nonresponsive may not be merit reviewed or considered for award (see Section III.C of the FOA).

Each Full Application should be limited to a single concept or technology. Unrelated concepts and technologies should not be consolidated in a single Full Application.

Fillable Full Application template documents are available on ARPA-E eXCHANGE at <https://arpa-e-foa.energy.gov>.

Full Applications must conform to the content requirements described below.

Component	Required Format	Description and Information
Technical Volume	PDF	The centerpiece of the Full Application. Provides a detailed description of the proposed R&D project and Project Team.
SF-424	PDF	Application for Federal Assistance. Applicants are responsible for ensuring that the proposed costs listed in eXCHANGE match those listed on forms SF-424 and

Questions about this FOA? Check the Frequently Asked Questions available at <http://arpa-e.energy.gov/faq>. For questions that have not already been answered, email ARPA-E-CO@hq.doe.gov (with FOA name and number in subject line); see FOA Sec. VII.A. Problems with ARPA-E eXCHANGE? Email ExchangeHelp@hq.doe.gov (with FOA name and number in subject line).

		SF-424A. Inconsistent submissions may impact ARPA-E’s final award determination.
Budget Justification Workbook/SF-424A	XLS	Budget Information – Non-Construction Programs
Summary for Public Release	PDF	Short summary of the proposed R&D project. Intended for public release.
Summary Slide	PPT	A four-panel project slide summarizing different aspects of the proposed R&D project.
Business Assurances & Disclosures Form	PDF	Requires the Applicant to make responsibility disclosures and disclose potential conflicts of interest within the Project Team. Requires the Applicant to describe the additionality and risks associated with the proposed project, disclose applications for funding currently pending with Federal and non-Federal entities, and disclose funding from Federal and non-Federal entities for work in the same technology area as the proposed R&D project. If the Applicant is a FFRDC/DOE Lab, requires the Applicant to provide written authorization from the cognizant Federal agency and, if a DOE/NNSA FFRDC/DOE Lab, a Field Work Proposal. Allows the Applicant to request a waiver or modification of the Performance of Work in the United States requirement and/or the Technology Transfer & Outreach (TT&O) spending requirement. A sample response to the Business Assurances & Disclosures Form is also available on ARPA-E eXCHANGE.
U.S. Manufacturing Plan	PDF	As part of the application, Applicants are required to submit a U.S. Manufacturing Plan. The U.S. Manufacturing Plan represents the Applicant’s measurable commitment to support U.S. manufacturing as a result of its award.

ARPA-E provides detailed guidance on the content and form of each component below.

1. FIRST COMPONENT: TECHNICAL VOLUME

The Technical Volume must be submitted in Adobe PDF format. A Technical Volume template is available at <https://arpa-e-foa.energy.gov>. The Technical Volume must conform to the content and form requirements included within the template, including maximum page lengths. If Applicants exceed the maximum page lengths specified for each section, ARPA-E will review only the authorized number of pages and disregard any additional pages.

Applicants must provide sufficient citations and references to the primary research literature to justify the claims and approaches made in the Technical Volume. ARPA-E and reviewers may review primary research literature in order to evaluate applications. However, ARPA-E and reviewers are under no obligation to review cited sources (e.g., Internet websites).

2. SECOND COMPONENT: SF-424

The SF-424 must be submitted in Adobe PDF format. This form is available on ARPA-E eXCHANGE at <https://arpa-e-foa.energy.gov>.

Questions about this FOA? Check the Frequently Asked Questions available at <http://arpa-e.energy.gov/faq>. For questions that have not already been answered, email ARPA-E-CO@hq.doe.gov (with FOA name and number in subject line); see FOA Sec. VII.A. Problems with ARPA-E eXCHANGE? Email ExchangeHelp@hq.doe.gov (with FOA name and number in subject line).

The SF-424 includes instructions for completing the form. Applicants are required to complete all required fields in accordance with the instructions.

Prime Recipients and Subrecipients are required to complete SF-LLL (Disclosure of Lobbying Activities), available at <https://www.grants.gov/forms/post-award-reporting-forms.html>, if any non-Federal funds have been paid or will be paid to any person for influencing or attempting to influence an officer or employee of any Federal agency, a Member of Congress, an officer or employee of Congress, or an employee of a Member of Congress in connection with your application or funding agreement. The completed SF-LLL must be appended to the SF-424.

ARPA-E provides the following supplemental guidance on completing the SF-424:

- Each Project Team should submit only one SF-424 (i.e., a Subrecipient should not submit a separate SF-424).
- The list of certifications and assurances in Block 21 can be found at <http://energy.gov/management/downloads/certifications-and-assurances-use-sf-424>.
- The dates and dollar amounts on the SF-424 are for the entire period of performance (from the project start date to the project end date), not a portion thereof.
- Applicants are responsible for ensuring that the proposed costs listed in eXCHANGE match those listed on forms SF-424 and SF-424A. Inconsistent submissions may impact ARPA-E's final award determination.

3. THIRD COMPONENT: BUDGET JUSTIFICATION WORKBOOK/SF-424A

Applicants are required to complete the Budget Justification Workbook/SF-424A Excel spreadsheet. This form is available on ARPA-E eXCHANGE at <https://arpa-e-foa.energy.gov>. Prime Recipients must complete each tab of the Budget Justification Workbook for the project as a whole, including all work to be performed by the Prime Recipient and its Subrecipients and Contractors. The SF-424A form included with the Budget Justification Workbook will "auto-populate" as the Applicant enters information into the Workbook. Applicants should carefully read the "Instructions and Summary" tab provided within the Budget Justification Workbook. Subrecipient information must be submitted as follows:

- Each Subrecipient incurring greater than or equal to 10% of the Total Project Cost must complete a separate Budget Justification workbook to justify its proposed budget. These worksheets must be inserted as additional sheets within in the Prime Recipient's Budget Justification.
- Subrecipients incurring less than 10% of the Total Project Cost are not required to complete a separate Budget Justification workbook. However, such Subrecipients are required to provide supporting documentation to justify their proposed budgets. At a

minimum, the supporting documentation must show which tasks/subtasks are being performed, the purpose/need for the effort, and a sufficient basis for the estimated costs.

ARPA-E provides the following supplemental guidance on completing the Budget Justification Workbook/SF-424A:

- Applicants may request funds under the appropriate object class category tabs as long as the item and amount requested are necessary to perform the proposed work, meet all the criteria for allowability under the applicable Federal cost principles, and are not prohibited by the funding restrictions described herein.
- If Patent costs are requested, they must be included in the Applicant's proposed budget (see Section IV.G.3 of the FOA for more information on Patent Costs).
- Unless a waiver is granted by ARPA-E, each Project Team must spend at least 5% of the Federal funding (i.e., the portion of the award that does not include the recipient's cost share) on Technology Transfer & Outreach (TT&O) activities to promote and further the development and deployment of ARPA-E-funded technologies.
- All TT&O costs requested must be included in the Applicant's proposed budget and identified as TT&O costs in the Budget Justification Workbook/SF-424A with the costs being requested under the "Other" budget category. All budgeted activities must relate to achieving specific objectives, technical milestones and deliverables outlined in Section 2.4 Task Descriptions of the Technical Volume.
- For more information, please refer to the ARPA-E Budget Justification Guidance document at <https://arpa-e-foa.energy.gov>.

4. FOURTH COMPONENT: SUMMARY FOR PUBLIC RELEASE

Applicants are required to provide a 250 word maximum Summary for Public Release. A Summary for Public Release template is available on ARPA-E eXCHANGE (<https://arpa-e-foa.energy.gov>). The Summary for Public Release must be submitted in Adobe PDF format. This summary should not include any confidential, proprietary, or privileged information. The summary should be written for a lay audience (e.g., general public, media, Congress) using plain English.

250 Words	SUMMARY FOR PUBLIC RELEASE	Briefly describe the proposed effort, summarize its objective(s) and technical approach, describe its ability to achieve the "Program Objectives" (see Section I.C of the FOA), and indicate its potential impact on "ARPA-E Mission Areas" (see Section I.A of the FOA). The summary should be written at technical level suitable for a high-school science student and is designed for public release. INSTRUCTIONS: (1) The Summary for Public Release shall not exceed 250 words and one paragraph.
------------------	-----------------------------------	---

Questions about this FOA? Check the Frequently Asked Questions available at <http://arpa-e.energy.gov/faq>. For questions that have not already been answered, email ARPA-E-CO@hq.doe.gov (with FOA name and number in subject line); see FOA Sec. VII.A. Problems with ARPA-E eXCHANGE? Email ExchangeHelp@hq.doe.gov (with FOA name and number in subject line).

		(2) The Summary for Public Release shall consist only of text—no graphics, figures, or tables. (3) For applications selected for award negotiations, the Summary may be used as the basis for a public announcement by ARPA-E; therefore, this Cover Page and Summary should not contain confidential or proprietary information . See Section VIII.I of the FOA for additional information on marking confidential information
--	--	---

5. FIFTH COMPONENT: SUMMARY SLIDE

Applicants are required to provide a single PowerPoint slide summarizing the proposed project. The slide must be submitted in Microsoft PowerPoint format. This slide will be used during ARPA-E's evaluation of Full Applications. A summary slide template and a sample summary slide are available on ARPA-E eXCHANGE (<https://arpa-e-foa.energy.gov>). Summary Slides must conform to the content requirements described below:

- A Technology Summary;
 - Bullet points that describe novel aspects of the proposed technology and technology approach;
- A description of the technology's impact;
 - Quantitative description (through text or graphic) of the impact the proposed project will provide to the market and ARPA-E mission areas;
- Proposed Targets;
 - Including any important technical performance metrics and/or impact categories;
 - Including quantitative description of the state of the art;
 - Including quantitative descriptions of the proposed targets;
- Any key graphics (illustrations, charts and/or tables) summarizing technology development and/or impact;
- The project's key idea/takeaway;
- Project title and Principal Investigator information; and
- Requested ARPA-E funds and proposed Applicant cost share.

6. SIXTH COMPONENT: BUSINESS ASSURANCES & DISCLOSURES FORM

Applicants are required to provide the information requested in the Business Assurances & Disclosures Form. The information must be submitted in Adobe PDF format. A fillable Business Assurances & Disclosures Form template is available on ARPA-E eXCHANGE at <https://arpa-e-foa.energy.gov>. A sample response to the Business Assurances & Disclosures Form is also available on ARPA-E eXCHANGE.

As described in the Business Assurances & Disclosures Form, the Applicant is required to:

Questions about this FOA? Check the Frequently Asked Questions available at <http://arpa-e.energy.gov/faq>. For questions that have not already been answered, email ARPA-E-CO@hq.doe.gov (with FOA name and number in subject line); see FOA Sec. VII.A. Problems with ARPA-E eXCHANGE? Email ExchangeHelp@hq.doe.gov (with FOA name and number in subject line).

- Disclose conditions bearing on responsibility, such as criminal convictions and Federal tax liability;
- Disclose potential conflicts of interest within the Project Team;
- If the Applicant is a FFRDC/DOE Lab, submit written authorization from the cognizant Federal agency; and
- If the Applicant is a DOE/NNSA FFRDC/DOE Lab, submit a Field Work Proposal.

In addition, ARPA-E is required by statute to “accelerat[e] transformational technological advances in areas that industry is by itself not likely to undertake because of technical and financial uncertainty.”⁴⁷ In accordance with ARPA-E’s statutory mandate, the Applicant is required to:

- Describe the additionality and risks associated with the proposed R&D project;
- Disclose any applications for the same project or related work currently pending with any Federal or non-Federal entities; and
- Disclose all funding for work in the same technology area as the proposed project received from any Federal or non-Federal entity within the last 5 years.

Finally, the Applicant may use the Business Assurances & Disclosures Form to:

- Request authorization to perform some work overseas; and
- Request a waiver of the TT&O spending requirement.

7. SEVENTH COMPONENT: U.S. MANUFACTURING PLAN

As part of the application, Applicants are required to submit a U.S. Manufacturing Plan that should not exceed one page in length. The U.S. Manufacturing Plan represents the Applicant’s measurable commitment to support U.S. manufacturing as a result of its award. U.S. Manufacturing Plans are a Program Policy Factor during the review and selection process. See Section V.B.1 of the FOA. A U.S. Manufacturing Plan must contain a commitment to the U.S. manufacturing requirements stated in Section VI.B.8 below.

In addition, the plan should include other specific and measurable commitments. For example, an Applicant may commit particular types of products to be manufactured in the U.S. These plans should not include requirements regarding the source of inputs used during the manufacturing process. In addition to or instead of making a commitment tied to a particular product, the Applicant may make other types of commitments still beneficial to U.S. manufacturing. An Applicant may commit to a particular investment in a new or existing U.S. manufacturing facility, keep certain activities based in the U.S. (i.e., final assembly), or support a certain number of jobs in the U.S. related to the technology and manufacturing.

⁴⁷ America COMPETES Act, Pub. L. No. 110-69, § 5012 (2007), as amended (codified at 42 U.S.C. § 16538).

When an Applicant is selected for an award, the U.S. Manufacturing Plan submitted by the Applicant will become part of the terms and conditions of the award. It is important to note that the U.S. Manufacturing Plan is in support of and not a replacement for the U.S. Manufacturing Requirement described in Section VI.B.8. The Applicant/Awardee may request a waiver or modification of the U.S. Manufacturing Plan from DOE/ARPA-E upon a showing that the original U.S. Manufacturing Plan is no longer economically feasible.

Class patent waivers usually apply to domestic large businesses as set forth in Section VIII.A of the FOA. Under this class patent waiver, domestic large businesses may elect title to their subject inventions similar to the right provided to the domestic small businesses, educational institutions, and nonprofits by law. In order to avail itself of the class patent waiver, a domestic large business must agree that any products embodying or produced through the use of an invention conceived or first actually reduced to practice under the award will be substantially manufactured in the United States, unless a waiver is granted by DOE/ARPA-E. The U.S. Manufacturing Plan submitted by the Applicant will become part of the terms and conditions of the award in addition to the requirements attaching to subject inventions.

E. CONTENT AND FORM OF REPLIES TO REVIEWER COMMENTS

Written feedback on Full Applications is made available to Applicants before the submission deadline for Replies to Reviewer Comments. Applicants have a brief opportunity to prepare a short Reply to Reviewer Comments responding to one or more comments or supplementing their Full Application. A fillable Reply to Reviewer Comments template is available on ARPA-E eXCHANGE (<https://arpa-e-foa.energy.gov>).

Replies to Reviewer Comments must conform to the following requirements:

- The Reply to Reviewer Comments must be submitted in Adobe PDF format.
- The Reply to Reviewer Comments must be written in English.
- All pages must be formatted to fit on 8-1/2 by 11 inch paper with margins not less than one inch on every side. Use Times New Roman typeface, a black font color, and a font size of 12 points or larger (except in figures and tables).
- The Control Number must be prominently displayed on the upper right corner of the header of every page. Page numbers must be included in the footer of every page.

ARPA-E may not review or consider noncompliant Replies to Reviewer Comments (see Section III.C.1 of the FOA). ARPA-E will review and consider each compliant and responsive Full Application, even if no Reply is submitted or if the Reply is found to be noncompliant.

Replies to Reviewer Comments must conform to the following content and form requirements, including maximum page lengths, described below. If a Reply to Reviewer Comments is more than three pages in length, ARPA-E will review only the first three pages and disregard any additional pages.

SECTION	PAGE LIMIT	DESCRIPTION
Text	2 pages maximum	<ul style="list-style-type: none">Applicants may respond to one or more reviewer comments or supplement their Full Application.
Images	1 page maximum	<ul style="list-style-type: none">Applicants may provide graphs, charts, or other data to respond to reviewer comments or supplement their Full Application.

F. INTERGOVERNMENTAL REVIEW

This program is not subject to Executive Order 12372 (Intergovernmental Review of Federal Programs).

G. FUNDING RESTRICTIONS

1. ALLOWABLE COSTS

All expenditures must be allowable, allocable, and reasonable in accordance with the applicable Federal cost principles. Pursuant to 2 C.F.R. § 910.352, the cost principles in the Federal Acquisition Regulations (48 C.F.R. Part 31.2) apply to for-profit entities. The cost principles contained in 2 C.F.R. Part 200, Subpart E apply to all entities other than for-profits.

2. PRE-AWARD COSTS

ARPA-E will not reimburse any pre-award costs incurred by Applicants before they are selected for award negotiations. Please refer to Section VI.A of the FOA for guidance on award notices.

Upon selection for award negotiations, Applicants may incur pre-award costs at their own risk, consistent with the requirements in 2 C.F.R. Part 200, as modified by 2 C.F.R. Part 910, and other Federal laws and regulations. ARPA-E generally does not accept budgets as submitted with the Full Application. Budgets are typically reworked during award negotiations. ARPA-E is under no obligation to reimburse pre-award costs if, for any reason, the Applicant does not receive an award or the award is made for a lesser amount than the Applicant expected, or if the costs incurred are not allowable, allocable, or reasonable.

3. PATENT COSTS

For Subject Inventions disclosed to DOE under an award, ARPA-E will reimburse the Prime Recipient – in addition to allowable costs associated with Subject Invention disclosures - up to \$30,000 of expenditures for filing and prosecution of United States patent applications, including international applications (“PCT application”) submitted to the United States Patent and Trademark Office (USPTO).

Questions about this FOA? Check the Frequently Asked Questions available at <http://arpa-e.energy.gov/faq>. For questions that have not already been answered, email ARPA-E-CO@hq.doe.gov (with FOA name and number in subject line); see FOA Sec. VII.A. Problems with ARPA-E eXCHANGE? Email ExchangeHelp@hq.doe.gov (with FOA name and number in subject line).

The Prime Recipient may request a waiver of the \$30,000 cap. Because all patent costs are considered to be Technology Transfer & Outreach (TT&O) costs (see Section IV.G.8 of the FOA below), the waiver request is subject to approval by ARPA-E.

4. CONSTRUCTION

ARPA-E generally does not fund projects that involve major construction. Recipients are required to obtain written authorization from the Contracting Officer before incurring any major construction costs.

5. FOREIGN TRAVEL

ARPA-E generally does not fund projects that involve foreign travel. Recipients are required to obtain written authorization from the ARPA-E Program Director before incurring any foreign travel costs and provide trip reports with their reimbursement requests.

6. PERFORMANCE OF WORK IN THE UNITED STATES

ARPA-E strongly encourages interdisciplinary and cross-sectoral collaboration spanning organizational boundaries. Such collaboration enables the achievement of scientific and technological outcomes that were previously viewed as extremely difficult, if not impossible.

ARPA-E requires all work under ARPA-E funding agreements to be performed in the United States – i.e., Prime Recipients must expend 100% of the Total Project Cost in the United States. However, Applicants may request a waiver of this requirement where their project would materially benefit from, or otherwise requires, certain work to be performed overseas.

Applicants seeking a waiver of this requirement are required to include an explicit request in the Business Assurances & Disclosures Form, which is part of the Full Application submitted to ARPA-E. Such waivers are granted where there is a demonstrated need, as determined by ARPA-E.

7. PURCHASE OF NEW EQUIPMENT

All equipment purchased under ARPA-E funding agreements must be made or manufactured in the United States, to the maximum extent practicable. This requirement does not apply to used or leased equipment. The Prime Recipients are required to notify the ARPA-E Contracting Officer reasonably in advance of purchasing any equipment that is not made or manufactured in the United States with a total acquisition cost of \$250,000 or more. The ARPA-E Contracting Officer will provide consent to purchase or reject within 30 calendar days of receipt of the Recipient's notification.

8. TECHNOLOGY TRANSFER AND OUTREACH

ARPA-E is required to contribute a percentage of appropriated funds to Technology Transfer and Outreach (TT&O) activities. In order to meet this mandate every Project Team must spend at least 5% of the Federal funding (i.e., the portion of the award that does not include the recipient's cost share) provided by ARPA-E on TT&O activities to promote and further the development and deployment of ARPA-E-funded technologies. Project Teams must also seek a waiver from ARPA-E to spend less than the minimum 5% TT&O expenditure requirement.

All TT&O expenditures are subject to the applicable Federal cost principles (i.e., 2 C.F.R. 200 Subpart E and 48 C.F.R. Subpart 31). Examples of TT&O expenditures are as follows:

- Documented travel and registration for the ARPA-E Energy Innovation Summit and other energy-related conferences and events;
- Documented travel to meet with potential suppliers, partners, or customers;
- Documented work by salaried or contract personnel to develop technology-to-market models or plans;
- Documented costs of acquiring industry-accepted market research reports; and
- Approved patent costs.

ARPA-E will not reimburse recipients for TT&O costs considered to be unallowable in accordance with the applicable cost principles. Examples of unallowable TT&O expenditures include:

- Meals or entertainment;
- Gifts to potential suppliers, partners, or customers;
- TT&O activities that do not relate to the ARPA-E-funded technologies;
- Undocumented TT&O activities; and
- TT&O activities unrelated and/or unallocable to the subject award.

Applicants may seek a waiver of the TT&O requirement by including an explicit request in the Business Assurances & Disclosures Form. Please refer to the Business Assurances & Disclosures Form for guidance on the content and form of the waiver request. ARPA-E may waive or modify the TT&O requirement, as appropriate.

For information regarding incorporation of TT&O costs into budget documentation, see Section IV.D.3 of the FOA.

9. LOBBYING

Prime Recipients and Subrecipients may not use any Federal funds, directly or indirectly, to influence or attempt to influence, directly or indirectly, congressional action on any legislative or appropriation matters pending before Congress, other than to communicate to Members of

Congress as described in 18 U.S.C. § 1913. This restriction is in addition to those prescribed elsewhere in statute and regulation.

Prime Recipients and Subrecipients are required to complete and submit SF-LLL, "Disclosure of Lobbying Activities" (<http://www.whitehouse.gov/sites/default/files/omb/grants/sflllin.pdf>) if any non-Federal funds have been paid or will be paid to any person for influencing or attempting to influence any of the following in connection with your application:

- An officer or employee of any Federal agency,
- A Member of Congress,
- An officer or employee of Congress, or
- An employee of a Member of Congress.

10. CONFERENCE SPENDING

Prime Recipients and Subrecipients may not use any Federal funds to:

- Defray the cost to the United States Government of a conference held by any Executive branch department, agency, board, commission, or office which is not directly and programmatically related to the purpose for which their ARPA-E award is made and for which the cost to the United States Government is more than \$20,000; or
- To circumvent the required notification by the head of any such Executive Branch department, agency, board, commission, or office to the Inspector General (or senior ethics official for any entity without an Inspector General), of the date, location, and number of employees attending such a conference.

11. INDEPENDENT RESEARCH AND DEVELOPMENT COSTS

ARPA-E does not fund Independent Research and Development (IR&D) as part of an indirect cost rate under its financial assistance awards. IR&D, as defined at FAR 31.205-18(a), includes cost of effort that is not sponsored by an assistance agreement or required in performance of a contract, and that consists of projects falling within the four following areas: (i) basic research, (ii) applied research, (iii) development, and (iv) systems and other concept formulation studies.

ARPA-E's goals are to enhance the economic and energy security of the United States through the development of energy technologies and ensure that the United States maintains a technological lead in developing and deploying advanced energy technologies. ARPA-E accomplishes these goals by providing financial assistance for energy technology projects, and has well recognized and established procedures for supporting research through competitive financial assistance awards based on merit review of proposed projects. Reimbursement for independent research and development costs through the indirect cost mechanism could circumvent this competitive process.

To ensure that all projects receive similar and equal consideration, eligible organizations may compete for direct funding of independent research projects they consider worthy of support by submitting proposals for those projects to ARPA-E. Since proposals for these projects may be submitted for direct funding, costs for independent research and development projects are not allowable as indirect costs under ARPA-E awards. IR&D costs, however, would still be included in the direct cost base that is used to calculate the indirect rate so as to ensure an appropriate allocation of indirect costs to the organization's direct cost centers.

H. OTHER SUBMISSION REQUIREMENTS

1. USE OF ARPA-E eXCHANGE

To apply to this FOA, Applicants must register with ARPA-E eXCHANGE (<https://arpa-e-foa.energy.gov/Registration.aspx>). Concept Papers, Full Applications, and Replies to Reviewer Comments must be submitted through ARPA-E eXCHANGE (<https://arpa-e-foa.energy.gov/login.aspx>). ARPA-E will not review or consider applications submitted through other means (e.g., fax, hand delivery, email, postal mail). For detailed guidance on using ARPA-E eXCHANGE, please refer to the "ARPA-E eXCHANGE Applicant Guide" (<https://arpa-e-foa.energy.gov/Manuals.aspx>).

Upon creating an application submission in ARPA-E eXCHANGE, Applicants will be assigned a Control Number. If the Applicant creates more than one application submission, a different Control Number will be assigned for each application.

Once logged in to ARPA-E eXCHANGE (<https://arpa-e-foa.energy.gov/login.aspx>), Applicants may access their submissions by clicking the "My Submissions" link in the navigation on the left side of the page. Every application that the Applicant has submitted to ARPA-E and the corresponding Control Number is displayed on that page. If the Applicant submits more than one application to a particular FOA, a different Control Number is shown for each application.

Applicants are responsible for meeting each submission deadline in ARPA-E eXCHANGE.

Applicants are strongly encouraged to submit their applications at least 48 hours in advance of the submission deadline. Under normal conditions (i.e., at least 48 hours in advance of the submission deadline), Applicants should allow at least 1 hour to submit a Concept Paper, or Full Application. In addition, Applicants should allow at least 15 minutes to submit a Reply to Reviewer Comments. Once the application is submitted in ARPA-E eXCHANGE, Applicants may revise or update their application until the expiration of the applicable deadline.

Applicants should not wait until the last minute to begin the submission process. During the final hours before the submission deadline, Applicants may experience server/connection congestion that prevents them from completing the necessary steps in ARPA-E eXCHANGE to submit their applications. **ARPA-E will not extend the submission deadline for Applicants that fail to submit required information and documents due to server/connection congestion.**

Questions about this FOA? Check the Frequently Asked Questions available at <http://arpa-e.energy.gov/faq>. For questions that have not already been answered, email ARPA-E-CO@hq.doe.gov (with FOA name and number in subject line); see FOA Sec. VII.A. Problems with ARPA-E eXCHANGE? Email ExchangeHelp@hq.doe.gov (with FOA name and number in subject line).

ARPA-E may not review or consider incomplete applications and applications received after the deadline stated in the FOA. Such applications may be deemed noncompliant (see Section III.C.1 of the FOA). The following errors could cause an application to be deemed “incomplete” and thus noncompliant:

- Failing to comply with the form and content requirements in Section IV of the FOA;
- Failing to enter required information in ARPA-E eXCHANGE;
- Failing to upload required document(s) to ARPA-E eXCHANGE;
- Failing to click the “Submit” button in ARPA-E eXCHANGE by the deadline stated in the FOA;
- Uploading the wrong document(s) or application(s) to ARPA-E eXCHANGE; and
- Uploading the same document twice, but labeling it as different documents. (In the latter scenario, the Applicant failed to submit a required document.)

ARPA-E urges Applicants to carefully review their applications and to allow sufficient time for the submission of required information and documents.

Questions about this FOA? Check the Frequently Asked Questions available at <http://arpa-e.energy.gov/faq>. For questions that have not already been answered, email ARPA-E-CO@hq.doe.gov (with FOA name and number in subject line); see FOA Sec. VII.A. Problems with ARPA-E eXCHANGE? Email ExchangeHelp@hq.doe.gov (with FOA name and number in subject line).

V. APPLICATION REVIEW INFORMATION

A. CRITERIA

ARPA-E performs a preliminary review of Concept Papers and Full Applications to determine whether they are compliant and responsive (see Section III.C of the FOA). ARPA-E also performs a preliminary review of Replies to Reviewer Comments to determine whether they are compliant.

ARPA-E considers a mix of quantitative and qualitative criteria in determining whether to encourage the submission of a Full Application and whether to select a Full Application for award negotiations.

1. CRITERIA FOR CONCEPT PAPERS

(1) *Impact of the Proposed Technology Relative to FOA Targets (50%)* - This criterion involves consideration of the following:

- The potential for a transformational and disruptive (not incremental) advancement compared to existing or emerging technologies;
- Achievement of the technical performance targets defined in Section I.D of the FOA.
- Identification of techno-economic challenges that must be overcome for the proposed technology to be commercially relevant; and
- Demonstration of awareness of competing commercial and emerging technologies and identifies how the proposed concept/technology provides significant improvement over existing solutions.

(2) *Overall Scientific and Technical Merit (50%)* - This criterion involves consideration of the following:

- The feasibility of the proposed work, as justified by appropriate background, theory, simulation, modeling, experimental data, or other sound scientific and engineering practices;
- Sufficiency of technical approach to accomplish the proposed R&D objectives, including why the proposed concept is more appropriate than alternative approaches and how technical risk will be mitigated;
- Clearly defined project outcomes and final deliverables; and
- The demonstrated capabilities of the individuals performing the project, the key capabilities of the organizations comprising the Project Team, the roles and responsibilities of each organization and (if applicable) previous collaborations among team members supporting the proposed project.

Questions about this FOA? Check the Frequently Asked Questions available at <http://arpa-e.energy.gov/faq>. For questions that have not already been answered, email ARPA-E-CO@hq.doe.gov (with FOA name and number in subject line); see FOA Sec. VII.A. Problems with ARPA-E eXCHANGE? Email ExchangeHelp@hq.doe.gov (with FOA name and number in subject line).

Submissions will not be evaluated against each other since they are not submitted in accordance with a common work statement. The above criteria will be weighted as follows:

Impact of the Proposed Technology Relative to FOA Targets	50%
Overall Scientific and Technical Merit	50%

2. CRITERIA FOR FULL APPLICATIONS

Full Applications are evaluated based on the following criteria:

(1) *Impact of the Proposed Technology (30%)* - This criterion involves consideration of the following:

- The potential for a transformational and disruptive (not incremental) advancement in one or more energy-related fields;
- Thorough understanding of the current state-of-the-art and presentation of an innovative technical approach to significantly improve performance over the current state-of-the-art;
- Awareness of competing commercial and emerging technologies and identification of how the proposed concept/technology provides significant improvement over these other solutions; and
- A reasonable and effective strategy for transitioning the proposed technology from the laboratory to commercial deployment.

(2) *Overall Scientific and Technical Merit (30%)* - This criterion involves consideration of the following:

- Whether the proposed work is unique and innovative;
- Clearly defined project outcomes and final deliverables;
- Substantiation that the proposed project is likely to meet or exceed the technical performance targets identified in this FOA;
- Feasibility of the proposed work based upon preliminary data or other background information and sound scientific and engineering practices and principles;
- A sound technical approach, including appropriately defined technical tasks, to accomplish the proposed R&D objectives; and
- Management of risk, to include identifying major technical R&D risks and feasible, effective mitigation strategies.

(3) *Qualifications, Experience, and Capabilities of the Proposed Project Team (30%)* - This criterion involves consideration of the following:

- The PI and Project Team have the skill and expertise needed to successfully execute

the project plan, evidenced by prior experience that demonstrates an ability to perform R&D of similar risk and complexity; and

- Access to the equipment and facilities necessary to accomplish the proposed R&D effort and/or a clear plan to obtain access to necessary equipment and facilities.

(4) *Soundness of Management Plan* (10%) - This criterion involves consideration of the following:

- Plausibility of plan to manage people and resources;
- Allocation of appropriate levels of effort and resources to proposed tasks;
- Reasonableness of the proposed project schedule, including major milestones; and
- Reasonableness of the proposed budget to accomplish the proposed project.

Submissions will not be evaluated against each other since they are not submitted in accordance with a common work statement.

The above criteria will be weighted as follows:

Impact of the Proposed Technology	30%
Overall Scientific and Technical Merit	30%
Qualifications, Experience, and Capabilities of the Proposed Project Team	30%
Soundness of Management Plan	10%

3. CRITERIA FOR REPLIES TO REVIEWER COMMENTS

ARPA-E has not established separate criteria to evaluate Replies to Reviewer Comments. Instead, Replies to Reviewer Comments are evaluated as an extension of the Full Application.

B. REVIEW AND SELECTION PROCESS

1. PROGRAM POLICY FACTORS

In addition to the above criteria, ARPA-E may consider the following program policy factors in determining which Concept Papers to encourage to submit a Full Application and which Full Applications to select for award negotiations:

- I. **ARPA-E Portfolio Balance.** Project balances ARPA-E portfolio in one or more of the following areas:
 - a. Diversity of technical personnel in the proposed Project Team;
 - b. Technological diversity;
 - c. Organizational diversity;
 - d. Geographic diversity;
 - e. Technical or commercialization risk; or

Questions about this FOA? Check the Frequently Asked Questions available at <http://arpa-e.energy.gov/faq>. For questions that have not already been answered, email ARPA-E-CO@hq.doe.gov (with FOA name and number in subject line); see FOA Sec. VII.A. Problems with ARPA-E eXCHANGE? Email ExchangeHelp@hq.doe.gov (with FOA name and number in subject line).

- f. Stage of technology development.
- II. **Relevance to ARPA-E Mission Advancement.** Project contributes to one or more of ARPA-E's key statutory goals:
- a. Reduction of U.S. dependence on foreign energy sources;
 - b. Stimulation of domestic manufacturing/U.S. Manufacturing Plan;
 - c. Reduction of energy-related emissions;
 - d. Increase in U.S. energy efficiency;
 - e. Enhancement of U.S. economic and energy security; or
 - f. Promotion of U.S. advanced energy technologies competitiveness.
- III. **Synergy of Public and Private Efforts.**
- a. Avoids duplication and overlap with other publicly or privately funded projects;
 - b. Promotes increased coordination with nongovernmental entities for demonstration of technologies and research applications to facilitate technology transfer; or
 - c. Increases unique research collaborations.
- IV. **Low likelihood of other sources of funding.** High technical and/or financial uncertainty that results in the non-availability of other public, private or internal funding or resources to support the project.
- V. **High-Leveraging of Federal Funds.** Project leverages Federal funds to optimize advancement of programmatic goals by proposing cost share above the required minimum or otherwise accessing scarce or unique resources.
- VI. **High Project Impact Relative to Project Cost.**
- VII. **Qualified Opportunity Zone (QOZ).** Whether the entity is located in an urban and economically distressed area including a Qualified Opportunity Zone (QOZ) or the proposed project will occur in a QOZ or otherwise advance the goals of QOZ. The goals include spurring economic development and job creation in distressed communities throughout the United States. For a list or map of QOZs go to: <https://www.cdfifund.gov/Pages/Opportunity-Zones.aspx>.

2. ARPA-E REVIEWERS

By submitting an application to ARPA-E, Applicants consent to ARPA-E's use of Federal employees, contractors, and experts from educational institutions, nonprofits, industry, and governmental and intergovernmental entities as reviewers. ARPA-E selects reviewers based on their knowledge and understanding of the relevant field and application, their experience and skills, and their ability to provide constructive feedback on applications.

ARPA-E requires all reviewers to complete a Conflict-of-Interest Certification and Nondisclosure Agreement through which they disclose their knowledge of any actual or apparent conflicts and agree to safeguard confidential information contained in Concept Papers, Full Applications, and Replies to Reviewer Comments. In addition, ARPA-E trains its reviewers in proper evaluation techniques and procedures.

Applicants are not permitted to nominate reviewers for their applications. Applicants may contact the Contracting Officer by email (ARPA-E-CO@hq.doe.gov) if they have knowledge of a potential conflict of interest or a reasonable belief that a potential conflict exists.

3. ARPA-E SUPPORT CONTRACTOR

ARPA-E utilizes contractors to assist with the evaluation of applications and project management. To avoid actual and apparent conflicts of interest, ARPA-E prohibits its support contractors from submitting or participating in the preparation of applications to ARPA-E.

By submitting an application to ARPA-E, Applicants represent that they are not performing support contractor services for ARPA-E in any capacity and did not obtain the assistance of ARPA-E's support contractor to prepare the application. ARPA-E will not consider any applications that are submitted by or prepared with the assistance of its support contractors.

C. ANTICIPATED ANNOUNCEMENT AND AWARD DATES

ARPA-E expects to announce selections for negotiations in approximately August 2020 and to execute funding agreements in approximately November 2020.

VI. AWARD ADMINISTRATION INFORMATION

A. AWARD NOTICES

1. REJECTED SUBMISSIONS

Noncompliant and nonresponsive Concept Papers and Full Applications are rejected by the Contracting Officer and are not merit reviewed or considered for award. The Contracting Officer sends a notification letter by email to the technical and administrative points of contact designated by the Applicant in ARPA-E eXCHANGE. The notification letter states the basis upon which the Concept Paper or Full Application was rejected.

2. CONCEPT PAPER NOTIFICATIONS

ARPA-E promptly notifies Applicants of its determination to encourage or discourage the submission of a Full Application. ARPA-E sends a notification letter by email to the technical and administrative points of contact designated by the Applicant in ARPA-E eXCHANGE. ARPA-E provides feedback in the notification letter in order to guide further development of the proposed technology.

Applicants may submit a Full Application even if they receive a notification discouraging them from doing so. By discouraging the submission of a Full Application, ARPA-E intends to convey its lack of programmatic interest in the proposed project. Such assessments do not necessarily reflect judgments on the merits of the proposed project. The purpose of the Concept Paper phase is to save Applicants the considerable time and expense of preparing a Full Application that is unlikely to be selected for award negotiations.

A notification letter encouraging the submission of a Full Application does not authorize the Applicant to commence performance of the project. Please refer to Section IV.G of the FOA for guidance on pre-award costs.

3. FULL APPLICATION NOTIFICATIONS

ARPA-E promptly notifies Applicants of its determination. ARPA-E sends a notification letter by email to the technical and administrative points of contact designated by the Applicant in ARPA-E eXCHANGE. The notification letter may inform the Applicant that its Full Application was selected for award negotiations, or not selected. Alternatively, ARPA-E may notify one or more Applicants that a final selection determination on particular Full Applications will be made at a later date, subject to the availability of funds and other factors.

Written feedback on Full Applications is made available to Applicants before the submission deadline for Replies to Reviewer Comments. By providing feedback, ARPA-E intends to guide

the further development of the proposed technology and to provide a brief opportunity to respond to reviewer comments.

a. SUCCESSFUL APPLICANTS

ARPA-E has discretion to select all or part of a proposed project for negotiation of an award. A notification letter selecting a Full Application for award negotiations does not authorize the Applicant to commence performance of the project. **ARPA-E selects Full Applications for award negotiations, not for award.** Applicants do not receive an award until award negotiations are complete and the Contracting Officer executes the funding agreement. ARPA-E may terminate award negotiations at any time for any reason.

Please refer to Section IV.G.2 of the FOA for guidance on pre-award costs.

b. POSTPONED SELECTION DETERMINATIONS

A notification letter postponing a final selection determination until a later date does not authorize the Applicant to commence performance of the project. ARPA-E may ultimately determine to select or not select the Full Application for award negotiations.

Please refer to Section IV.G.2 of the FOA for guidance on pre-award costs.

c. UNSUCCESSFUL APPLICANTS

By not selecting a Full Application, ARPA-E intends to convey its lack of programmatic interest in the proposed project. Such assessments do not necessarily reflect judgments on the merits of the proposed project. ARPA-E hopes that unsuccessful Applicants will submit innovative ideas and concepts for future FOAs.

B. ADMINISTRATIVE AND NATIONAL POLICY REQUIREMENTS

The following administrative and national policy requirements apply to Prime Recipients. The Prime Recipient is the responsible authority regarding the settlement and satisfaction of all contractual and administrative issues, including but not limited to disputes and claims arising out of any agreement between the Prime Recipient and a FFRDC contractor. Prime Recipients are required to flow down these requirements to their Subrecipients through subawards or related agreements.

1. DUNS NUMBER AND SAM, FSRS, AND FEDCONNECT REGISTRATIONS

Prime Recipients and Subrecipients are required to obtain a Dun and Bradstreet Data Universal Numbering System (DUNS) number at <http://fedgov.dnb.com/webform> and to register with the System for Award Management (SAM) at <https://www.sam.gov/portal/public/SAM/>.

Prime Recipients and Subrecipients should commence this process as soon as possible in order to expedite the execution of a funding agreement. Obtaining a DUNS number and registering with SAM could take several weeks.

Prime Recipients are also required to register with the Federal Funding Accountability and Transparency Act Subaward Reporting System (FSRS) at <https://www.fsrs.gov/>.⁴⁸ Prime Recipients are required to report to FSRS the names and total compensation of each of the Prime Recipient's five most highly compensated executives and the names and total compensation of each Subrecipient's five most highly compensated executives. Please refer to <https://www.fsrs.gov/> for guidance on reporting requirements.

ARPA-E may not execute a funding agreement with the Prime Recipient until it has obtained a DUNS number and completed its SAM and FSRS registrations. In addition, the Prime Recipient may not execute subawards with Subrecipients until they obtain a DUNS number and complete their SAM registration. Prime Recipients and Subrecipients are required to keep their SAM and FSRS data current throughout the duration of the project.

Finally, Prime Recipients are required to register with FedConnect in order to receive notification that their funding agreement has been executed by the Contracting Officer and to obtain a copy of the executed funding agreement. Please refer to <https://www.fedconnect.net/FedConnect/> for registration instructions.

2. NATIONAL POLICY ASSURANCES

Project Teams, including Prime Recipients and Subrecipients, are required to comply with the National Policy Assurances attached to their funding agreement in accordance with 2 C.F.R. 200.300. Please refer to Attachment 6 of ARPA-E's Model Cooperative Agreement (<https://arpa-e.energy.gov/?q=site-page/funding-agreements>) for information on the National Policy Assurances.

3. PROOF OF COST SHARE COMMITMENT AND ALLOWABILITY

Upon selection for award negotiations, the Prime Recipient must confirm in writing that the proposed cost share contribution is allowable in accordance with applicable Federal cost principles.

The Prime Recipient is also required to provide cost share commitment letters from Subrecipients or third parties that are providing cost share, whether cash or in-kind. Each Subrecipient or third party that is contributing cost share must provide a letter on appropriate letterhead that is signed by an authorized corporate representative.

⁴⁸ The Federal Funding Accountability and Transparency Act, P.L. 109-282, 31 U.S.C. 6101 note.

4. COST SHARE PAYMENTS⁴⁹

All proposed cost share contributions must be reviewed in advance by the Contracting Officer and incorporated into the project budget before the expenditures are incurred.

The Prime Recipient is required to pay the “Cost Share” amount as a percentage of the total project costs in each invoice period for the duration of the period of performance. Small Businesses see Section III.B.3 of the FOA.

ARPA-E may deny reimbursement requests, in whole or in part, or modify or terminate funding agreements where Prime Recipients (or Project Teams) fail to comply with ARPA-E’s cost share payment requirements.

5. ENVIRONMENTAL IMPACT QUESTIONNAIRE

By law, ARPA-E is required to evaluate the potential environmental impact of projects that it is considering for funding. In particular, ARPA-E must determine before funding a project whether the project qualifies for a categorical exclusion under 10 C.F.R. § 1021.410 or whether it requires further environmental review (i.e., an environmental assessment or an environmental impact statement).

To facilitate and expedite ARPA-E’s environmental review, Prime Recipients are required to complete an Environmental Impact Questionnaire during award negotiations. This form is available at <https://arpa-e.energy.gov/?q=site-page/required-forms-and-templates>. The Environmental Impact Questionnaire is due within 21 calendar days of the selection announcement.

6. TECHNOLOGY-TO-MARKET PLAN

During award negotiations, Prime Recipients are required to negotiate and submit an initial Technology-to-Market Plan to the ARPA-E Program Director, and obtain the ARPA-E Program Director’s approval prior to the execution of the award. Prime Recipients must show how budgeted Technology Transfer and Outreach (TT&O) costs relate to furthering elements of the Technology-to-Market Plan. During the period of performance, Prime Recipients are required to provide regular updates on the initial Technology-to-Market plan and report on implementation of Technology-to-Market activities. Prime Recipients may be required to perform other actions to further the commercialization of their respective technologies.

ARPA-E may waive or modify this requirement, as appropriate.

7. INTELLECTUAL PROPERTY AND DATA MANAGEMENT PLANS

⁴⁹ Please refer to Section III.B of the FOA for guidance on cost share requirements.

ARPA-E requires every Project Team to negotiate and establish an Intellectual Property Management Plan for the management and disposition of intellectual property arising from the project. The Prime Recipient must submit a completed and signed Intellectual Property Management plan to ARPA-E within six weeks of the effective date of the ARPA-E funding agreement. All Intellectual Property Management Plans are subject to the terms and conditions of the ARPA-E funding agreement and its intellectual property provisions, and applicable Federal laws, regulations, and policies, all of which take precedence over the terms of Intellectual Property Management Plans.

ARPA-E has developed a template for Intellectual Property Management Plans (<https://arpa-e.energy.gov/?q=site-page/project-management-reporting-requirements>) so as to facilitate and expedite negotiations between Project Team members. ARPA-E does not mandate the use of this template. ARPA-E and DOE do not make any warranty (express or implied) or assume any liability or responsibility for the accuracy, completeness, or usefulness of the template. ARPA-E and DOE strongly encourage Project Teams to consult independent legal counsel before using the template.

Awardees are also required, post-award, to submit a Data Management Plan (DMP) that addresses how data generated in the course of the work performed under an ARPA-E award will be preserved and, as appropriate, shared publicly. The Prime Recipient must submit a completed and signed DMP - as part of the Team's Intellectual Property Management Plan - to ARPA-E within six weeks of the effective date of the ARPA-E funding agreement.

8. U.S. MANUFACTURING REQUIREMENT

As part of its Full Application, each applicant is required to submit a U.S. Manufacturing Plan that includes the following U.S. Manufacturing Requirements. For more information on the required U.S Manufacturing Plan, see Section IV.D.7 above.

a. SMALL BUSINESSES

Small businesses (and in rare cases where a nonprofit might manufacture) that are Prime Recipients or Subrecipients under ARPA-E funding agreements must agree that any products embodying any subject invention or produced through the use of any subject invention will be manufactured substantially in the United States for any use or sale anywhere in the world.

Small business must also agree that, for their exclusive and nonexclusive licensees, any products that embody any subject invention or that will be produced through the use of any subject invention will be manufactured substantially in the United States for any use or sale anywhere in the world.

Small businesses must require their assignees and entities acquiring a controlling interest in the small business to apply the same U.S. Manufacturing requirements to their licensees.

b. LARGE BUSINESSES

Large businesses that are Prime Recipients or Subrecipients (and in rare cases, foreign entities that are Subrecipients) under ARPA-E funding agreements are required to substantially manufacture the following products in the United States: (1) products embodying subject inventions, and (2) products produced through the use of subject inventions. This requirement applies to products that are manufactured for use or sale in the United States and outside the United States.

Large businesses (and in rare cases, foreign entities that are Subrecipients) must apply the same U.S. Manufacturing requirements to their assignees, licensees, and entities acquiring a controlling interest in the large business or foreign entity. Large businesses must require their assignees and entities acquiring a controlling interest in the large business to apply the same U.S. Manufacturing requirements to their licensees.

c. EDUCATIONAL INSTITUTIONS AND NONPROFITS

Domestic educational institutions and nonprofits that are Prime Recipients or Subrecipients under ARPA-E funding agreements must require their exclusive and nonexclusive licensees to substantially manufacture the following products in the United States for any use or sale anywhere in the world: (1) articles embodying subject inventions, and (2) articles produced through the use of subject inventions. Educational institutions and nonprofits must require their assignees to apply the same U.S. Manufacturing requirements to their licensees.

d. FFRDCs/DOE LABS AND STATE AND LOCAL GOVERNMENT ENTITIES

FFRDCs/DOE Labs that are GOCOs and state and local government entities that are Prime Recipients or Subrecipients under ARPA-E funding agreements must require their exclusive licensees to substantially manufacture the following products in the United States for any use or sale in the United States: (1) products embodying subject inventions, and (2) products produced through the use of subject inventions. This requirement does not apply to products that are manufactured for use or sale overseas. They must also require their assignees to apply the same U.S. Manufacturing requirements to their exclusive licensees. GOGOs are subject to the requirements in 37 CFR § 404.5(a)(2).

e. CRITERIA FOR WAIVING U.S. MANUFACTURING REQUIREMENTS

ARPA-E seeks to “enhance the economic and energy security of the United States ...” and “ensure that the United States maintains a technological lead in developing and deploying advanced energy technologies.” The preferred benefit to the U.S. economy is the creation and maintenance of manufacturing capabilities and jobs within the United States. However, an applicant or awardee may request a modification or waiver of the standard U.S. Manufacturing Requirement, or its submitted U.S. Manufacturing Plan, if the applicant/awardee can

demonstrate to the satisfaction of DOE/ARPA-E that it is not commercially feasible to comply with U.S. manufacturing requirements. In addition, such requests must include a description of specific economic or other benefits to the U.S. economy which are related to the commercial use by requestor of the technology being funded by ARPA-E and which are commensurate with the Government's contribution to the proposed work. These types of benefits are more easily measured and evaluated after technical advance has been made under an award, such as by the making of a subject invention.

Such benefits may include one or more of the following:

- Direct or indirect investment in U.S.-based plant and equipment.
- Creation of new and/or higher-quality U.S.-based jobs.
- Enhancement of the domestic skills base.
- Further domestic development of the technology.
- Significant reinvestment of profits in the domestic economy.
- Positive impact on the U.S. balance of payments in terms of product and service exports as well as foreign licensing royalties and receipts.
- Appropriate recognition of U.S. taxpayer support for the technology; e.g., a quid-pro-quo commensurate with the economic benefit that would be domestically derived by the U.S. taxpayer from U.S.-based manufacture.
- Cross-licensing, sublicensing, and reassignment provisions in licenses which seek to maximize the benefits to the U.S. taxpayer.
- Any foreign manufacturing/use will occur in a country that protects U.S. patents/intellectual property.

9. CORPORATE FELONY CONVICTIONS AND FEDERAL TAX LIABILITY

In submitting an application in response to this FOA, the Applicant represents that:

- It is not a corporation that has been convicted of a felony criminal violation under any Federal law within the preceding 24 months; and
- It is not a corporation that has any unpaid Federal tax liability that has been assessed, for which all judicial and administrative remedies have been exhausted or have lapsed, and that is not being paid in a timely manner pursuant to an agreement with the authority responsible for collecting the tax liability.

For purposes of these representations the following definitions apply: A Corporation includes any entity that has filed articles of incorporation in any of the 50 states, the District of Columbia, or the various territories of the United States [but not foreign corporations]. It includes both for-profit and non-profit organizations.

10. APPLICANT RISK ANALYSIS

If selected for award negotiations, ARPA-E may evaluate the risks posed by the Applicant using the criteria set forth at 2 CFR §200.205(c), subparagraphs (1) through (4). ARPA-E may require special award terms and conditions depending upon results of the risk analysis.

11. RECIPIENT INTEGRITY AND PERFORMANCE MATTERS

Prior to making a Federal award with a total amount of Federal share greater than the simplified acquisition threshold (presently \$250,000), ARPA-E is required to review and consider any information about Applicants that is contained in the Office of Management and Budget's designated integrity and performance system accessible through SAM (currently the Federal Awardee Performance and Integrity Information System or FAPIIS) (41 U.S.C. § 2313 and 2 C.F.R. 200.205).

Applicants may review information in FAPIIS and comment on any information about itself that a Federal awarding agency previously entered into FAPIIS.

ARPA-E will consider any written comments provided by Applicants during award negotiations, in addition to the other information in FAPIIS, in making a judgment about an Applicant's integrity, business ethics, and record of performance under Federal awards when reviewing potential risk posed by Applicants as described in 2 C.F.R. §200.205.

12. NONDISCLOSURE AND CONFIDENTIALITY AGREEMENTS REPRESENTATIONS

In submitting an application in response to this FOA the Applicant represents that:

- (1) **It does not and will not** require its employees or contractors to sign internal nondisclosure or confidentiality agreements or statements prohibiting or otherwise restricting its employees or contractors from lawfully reporting waste, fraud, or abuse to a designated investigative or law enforcement representative of a Federal department or agency authorized to receive such information.
- (2) **It does not and will not** use any Federal funds to implement or enforce any nondisclosure and/or confidentiality policy, form, or agreement it uses unless it contains the following provisions:
 - a. *“These provisions are consistent with and do not supersede, conflict with, or otherwise alter the employee obligations, rights, or liabilities created by existing statute or Executive order relating to (1) classified information, (2) communications to Congress, (3) the reporting to an Inspector General of a violation of any law, rule, or regulation, or mismanagement, a gross waste of funds, an abuse of authority, or a substantial and specific danger to public health or safety, or (4) any other whistleblower protection. The definitions, requirements, obligations, rights,*

sanctions, and liabilities created by controlling Executive orders and statutory provisions are incorporated into this agreement and are controlling.”

- b. The limitation above shall not contravene requirements applicable to Standard Form 312, Form 4414, or any other form issued by a Federal department or agency governing the nondisclosure of classified information.
- c. Notwithstanding provision listed in paragraph (a), a nondisclosure confidentiality policy form or agreement that is to be executed by a person connected with the conduct of an intelligence or intelligence-related activity, other than an employee or officer of the United States Government, may contain provisions appropriate to the particular activity for which such document is to be used. Such form or agreement shall, at a minimum, require that the person will not disclose any classified information received in the course of such activity unless specifically authorized to do so by the United States Government. Such nondisclosure or confidentiality forms shall also make it clear that they do not bar disclosure to congress, or to an authorized official of an executive agency or the Department of Justice, that are essential to reporting a substantial violation of law.

C. REPORTING

Recipients are required to submit periodic, detailed reports on technical, financial, and other aspects of the project, as described in Attachment 4 to ARPA-E's Model Cooperative Agreement (<https://arpa-e.energy.gov/?q=site-page/funding-agreements>).

VII. AGENCY CONTACTS

A. COMMUNICATIONS WITH ARPA-E

Upon the issuance of a FOA, only the Contracting Officer may communicate with Applicants. ARPA-E personnel and our support contractors are prohibited from communicating (in writing or otherwise) with Applicants regarding the FOA. This “quiet period” remains in effect until ARPA-E’s public announcement of its project selections.

During the “quiet period,” Applicants are required to submit all questions regarding this FOA to ARPA-E-CO@hq.doe.gov. Questions and Answers (Q&As) about ARPA-E and the FOA are available at <http://arpa-e.energy.gov/faq>. For questions that have not already been answered, please send an email with the FOA name and number in the subject line to ARPA-E-CO@hq.doe.gov. Due to the volume of questions received, ARPA-E will only answer pertinent questions that have not yet been answered and posted at the above link.

- ARPA-E will post responses on a weekly basis to any questions that are received that have not already been addressed at the link above. ARPA-E may re-phrase questions or consolidate similar questions for administrative purposes.
- ARPA-E will cease to accept questions approximately 10 business days in advance of each submission deadline. Responses to questions received before the cutoff will be posted approximately one business day in advance of the submission deadline. ARPA-E may re-phrase questions or consolidate similar questions for administrative purposes.
- Responses are published in a document specific to this FOA under “CURRENT FUNDING OPPORTUNITIES – FAQs” on ARPA-E’s website (<http://arpa-e.energy.gov/faq>).

Applicants may submit questions regarding ARPA-E eXCHANGE, ARPA-E’s online application portal, to ExchangeHelp@hq.doe.gov. ARPA-E will promptly respond to emails that raise legitimate, technical issues with ARPA-E eXCHANGE. ARPA-E will refer any questions regarding the FOA to ARPA-E-CO@hq.doe.gov.

ARPA-E will not accept or respond to communications received by other means (e.g., fax, telephone, mail, hand delivery). Emails sent to other email addresses will be disregarded.

During the “quiet period,” only the Contracting Officer may authorize communications between ARPA-E personnel and Applicants. The Contracting Officer may communicate with Applicants as necessary and appropriate. As described in Section IV.A of the FOA, the Contracting Officer may arrange pre-selection meetings and/or site visits during the “quiet period.”

Questions about this FOA? Check the Frequently Asked Questions available at <http://arpa-e.energy.gov/faq>. For questions that have not already been answered, email ARPA-E-CO@hq.doe.gov (with FOA name and number in subject line); see FOA Sec. VII.A. Problems with ARPA-E eXCHANGE? Email ExchangeHelp@hq.doe.gov (with FOA name and number in subject line).

B. DEBRIEFINGS

ARPA-E does not offer or provide debriefings. ARPA-E provides Applicants with a notification encouraging or discouraging the submission of a Full Application based on ARPA-E's assessment of the Concept Paper. In addition, ARPA-E provides Applicants with reviewer comments on Full Applications before the submission deadline for Replies to Reviewer Comments.

Questions about this FOA? Check the Frequently Asked Questions available at <http://arpa-e.energy.gov/faq>. For questions that have not already been answered, email ARPA-E-CO@hq.doe.gov (with FOA name and number in subject line); see FOA Sec. VII.A. Problems with ARPA-E eXCHANGE? Email ExchangeHelp@hq.doe.gov (with FOA name and number in subject line).

VIII. OTHER INFORMATION

A. TITLE TO SUBJECT INVENTIONS

Ownership of subject inventions is governed pursuant to the authorities listed below. Typically, either by operation of law or under the authority of a patent waiver, Prime Recipients and Subrecipients may elect to retain title to their subject inventions under ARPA-E funding agreements.

- Domestic Small Businesses, Educational Institutions, and Nonprofits: Under the Bayh-Dole Act (35 U.S.C. § 200 et seq.), domestic small businesses, educational institutions, and nonprofits may elect to retain title to their subject inventions. If Prime Recipients/Subrecipients elect to retain title, they must file a patent application in a timely fashion, generally one year from election of title, though: a) extensions can be granted, and b) earlier filing is required for certain situations (“statutory bars,” governed by 35 U.S.C. § 102) involving publication, sale, or public use of the subject invention.
- All other parties: The Federal Non-Nuclear Energy Research and Development Act of 1974, 42 U.S.C. 5908, provides that the Government obtains title to new inventions unless a waiver is granted (*see below*).
- Class Waiver: Under 42 U.S.C. § 5908, title to subject inventions vests in the U.S. Government and large businesses and foreign entities do not have the automatic right to elect to retain title to subject inventions. However, ARPA-E typically issues “class patent waivers” under which large businesses and foreign entities that meet certain stated requirements, such as cost sharing of at least 20%, may elect to retain title to their subject inventions. If a large business or foreign entity elects to retain title to its subject invention, it must file a patent application in a timely fashion. If the class waiver does not apply, a party may request a waiver in accordance with 10 C.F.R. §784.
- GOGOs are subject to the requirements of 37 C.F.R. Part 501.
- Determination of Exceptional Circumstances (DEC): DOE has determined that exceptional circumstances exist that warrant the modification of the standard patent rights clause for small businesses and non-profit awardees under Bayh-Dole to maximize the manufacture of technologies supported by ARPA-E awards in the United States. The DEC, including a right of appeal, is dated September 9, 2013 and is available at the following link: <http://energy.gov/gc/downloads/determination-exceptional-circumstances-under-bayh-dole-act-energy-efficiency-renewable>. Please see Section IV.D and VI.B for more information on U.S. Manufacturing Requirements.

B. GOVERNMENT RIGHTS IN SUBJECT INVENTIONS

Where Prime Recipients and Subrecipients retain title to subject inventions, the U.S. Government retains certain rights.

Questions about this FOA? Check the Frequently Asked Questions available at <http://arpa-e.energy.gov/faq>. For questions that have not already been answered, email ARPA-E-CO@hq.doe.gov (with FOA name and number in subject line); see FOA Sec. VII.A. Problems with ARPA-E eXCHANGE? Email ExchangeHelp@hq.doe.gov (with FOA name and number in subject line).

1. GOVERNMENT USE LICENSE

The U.S. Government retains a nonexclusive, nontransferable, irrevocable, paid-up license to practice or have practiced for or on behalf of the United States any subject invention throughout the world. This license extends to contractors doing work on behalf of the Government.

2. MARCH-IN RIGHTS

The U.S. Government retains march-in rights with respect to all subject inventions. Through “march-in rights,” the Government may require a Prime Recipient or Subrecipient who has elected to retain title to a subject invention (or their assignees or exclusive licensees), to grant a license for use of the invention. In addition, the Government may grant licenses for use of the subject invention when Prime Recipients, Subrecipients, or their assignees and exclusive licensees refuse to do so.

The U.S. Government may exercise its march-in rights if it determines that such action is necessary under any of the four following conditions:

- The owner or licensee has not taken or is not expected to take effective steps to achieve practical application of the invention within a reasonable time;
- The owner or licensee has not taken action to alleviate health or safety needs in a reasonably satisfactory manner;
- The owner has not met public use requirements specified by Federal statutes in a reasonably satisfactory manner; or
- The U.S. Manufacturing requirement has not been met.

C. RIGHTS IN TECHNICAL DATA

Data rights differ based on whether data is first produced under an award or instead was developed at private expense outside the award.

- Background or “Limited Rights Data”: The U.S. Government will not normally require delivery of technical data developed solely at private expense prior to issuance of an award, except as necessary to monitor technical progress and evaluate the potential of proposed technologies to reach specific technical and cost metrics.
- Generated Data: The U.S. Government normally retains very broad rights in technical data produced under Government financial assistance awards, including the right to distribute to the public. However, pursuant to special statutory authority, certain categories of data generated under ARPA-E awards may be protected from public disclosure for up to five years in accordance with provisions that will be set forth in the award. In addition, invention disclosures may be protected from public disclosure for a reasonable time in order to allow for filing a patent application.

D. PROTECTED PERSONALLY IDENTIFIABLE INFORMATION

Applicants may not include any Protected Personally Identifiable Information (Protected PII) in their submissions to ARPA-E. Protected PII is defined as data that, if compromised, could cause harm to an individual such as identity theft. Listed below are examples of Protected PII that Applicants must not include in their submissions.

- Social Security Numbers in any form;
- Place of Birth associated with an individual;
- Date of Birth associated with an individual;
- Mother's maiden name associated with an individual;
- Biometric record associated with an individual;
- Fingerprint;
- Iris scan;
- DNA;
- Medical history information associated with an individual;
- Medical conditions, including history of disease;
- Metric information, e.g. weight, height, blood pressure;
- Criminal history associated with an individual;
- Ratings;
- Disciplinary actions;
- Performance elements and standards (or work expectations) are PII when they are so intertwined with performance appraisals that their disclosure would reveal an individual's performance appraisal;
- Financial information associated with an individual;
- Credit card numbers;
- Bank account numbers; and
- Security clearance history or related information (not including actual clearances held).

E. FOAs AND FOA MODIFICATIONS

FOAs are posted on ARPA-E eXCHANGE (<https://arpa-e-foa.energy.gov/>), Grants.gov (<http://www.grants.gov/>), and FedConnect (<https://www.fedconnect.net/FedConnect/>). Any modifications to the FOA are also posted to these websites. You can receive an e-mail when a modification is posted by registering with FedConnect as an interested party for this FOA. It is recommended that you register as soon as possible after release of the FOA to ensure that you receive timely notice of any modifications or other announcements. More information is available at <https://www.fedconnect.net>.

F. OBLIGATION OF PUBLIC FUNDS

The Contracting Officer is the only individual who can make awards on behalf of ARPA-E or

Questions about this FOA? Check the Frequently Asked Questions available at <http://arpa-e.energy.gov/faq>. For questions that have not already been answered, email ARPA-E-CO@hq.doe.gov (with FOA name and number in subject line); see FOA Sec. VII.A. Problems with ARPA-E eXCHANGE? Email ExchangeHelp@hq.doe.gov (with FOA name and number in subject line).

obligate ARPA-E to the expenditure of public funds. A commitment or obligation by any individual other than the Contracting Officer, either explicit or implied, is invalid.

ARPA-E awards may not be transferred, assigned, or assumed without the prior written consent of a Contracting Officer.

G. REQUIREMENT FOR FULL AND COMPLETE DISCLOSURE

Applicants are required to make a full and complete disclosure of the information requested in the Business Assurances & Disclosures Form. Disclosure of the requested information is mandatory. Any failure to make a full and complete disclosure of the requested information may result in:

- The rejection of a Concept Paper, Full Application, and/or Reply to Reviewer Comments;
- The termination of award negotiations;
- The modification, suspension, and/or termination of a funding agreement;
- The initiation of debarment proceedings, debarment, and/or a declaration of ineligibility for receipt of Federal contracts, subcontracts, and financial assistance and benefits; and
- Civil and/or criminal penalties.

H. RETENTION OF SUBMISSIONS

ARPA-E expects to retain copies of all Concept Papers, Full Applications, Replies to Reviewer Comments, and other submissions. No submissions will be returned. By applying to ARPA-E for funding, Applicants consent to ARPA-E's retention of their submissions.

I. MARKING OF CONFIDENTIAL INFORMATION

ARPA-E will use data and other information contained in Concept Papers, Full Applications, and Replies to Reviewer Comments strictly for evaluation purposes.

Concept Papers, Full Applications, Replies to Reviewer Comments, and other submissions containing confidential, proprietary, or privileged information must be marked as described below. Failure to comply with these marking requirements may result in the disclosure of the unmarked information under the Freedom of Information Act or otherwise. The U.S. Government is not liable for the disclosure or use of unmarked information, and may use or disclose such information for any purpose.

The cover sheet of the Concept Paper, Full Application, Reply to Reviewer Comments, or other submission must be marked as follows and identify the specific pages containing confidential, proprietary, or privileged information:

Questions about this FOA? Check the Frequently Asked Questions available at <http://arpa-e.energy.gov/faq>. For questions that have not already been answered, email ARPA-E-CO@hq.doe.gov (with FOA name and number in subject line); see FOA Sec. VII.A. Problems with ARPA-E eXCHANGE? Email ExchangeHelp@hq.doe.gov (with FOA name and number in subject line).

Notice of Restriction on Disclosure and Use of Data:

Pages [] of this document may contain confidential, proprietary, or privileged information that is exempt from public disclosure. Such information shall be used or disclosed only for evaluation purposes or in accordance with a financial assistance or loan agreement between the submitter and the Government. The Government may use or disclose any information that is not appropriately marked or otherwise restricted, regardless of source.

The header and footer of every page that contains confidential, proprietary, or privileged information must be marked as follows: "Contains Confidential, Proprietary, or Privileged Information Exempt from Public Disclosure." In addition, every line and paragraph containing proprietary, privileged, or trade secret information must be clearly marked with double brackets or highlighting.

J. COMPLIANCE AUDIT REQUIREMENT

A prime recipient organized as a for-profit entity expending \$750,000 or more of DOE funds in the entity's fiscal year (including funds expended as a Subrecipient) must have an annual compliance audit performed at the completion of its fiscal year. For additional information, refer to Subpart F of: (i) 2 C.F.R. Part 200, and (ii) 2 C.F.R. Part 910.

If an educational institution, non-profit organization, or state/local government is either a Prime Recipient or a Subrecipient, and has expended \$750,000 or more of Federal funds in the entity's fiscal year, the entity must have an annual compliance audit performed at the completion of its fiscal year. For additional information refer to Subpart F of 2 C.F.R. Part 200.

IX. GLOSSARY

Applicant: The entity that submits the application to ARPA-E. In the case of a Project Team, the Applicant is the lead organization listed on the application.

Application: The entire submission received by ARPA-E, including the Concept Paper, Full Application, and Reply to Reviewer Comments.

ARPA-E: is the Advanced Research Projects Agency – Energy, an agency of the U.S. Department of Energy.

Cost Sharing: is the portion of project costs not paid by Federal funds (unless otherwise authorized by Federal statute). Refer to 2 C.F.R. § 200.29.

Deliverable: A deliverable is the quantifiable goods or services that will be provided upon the successful completion of a project task or sub-task.

DOE: U.S. Department of Energy.

DOE/NNSA: U.S. Department of Energy/National Nuclear Security Administration

FFRDCs: Federally Funded Research and Development Centers.

FOA: Funding Opportunity Announcement.

For-Profit Organizations (Other than Small Businesses) (or large businesses): Means entities organized for-profit other than small businesses as defined elsewhere in this Glossary.

GOCOs: U.S. Government Owned, Contractor Operated laboratories.

GOGOs: U.S. Government Owned, Government Operated laboratories.

Institutions of Higher Education (or educational institutions): Has the meaning set forth at 20 U.S.C. 1001.

Milestone: A milestone is the tangible, observable measurement that will be provided upon the successful completion of a project task or sub-task.

Nonprofit Organizations (or nonprofits): Has the meaning set forth at 2 C.F.R. § 200.70.

Prime Recipient: The signatory to the funding agreement with ARPA-E.

PI: Principal Investigator.

Project Team: A Project Team consists of the Prime Recipient, Subrecipients, and others performing any of the research and development work under an ARPA-E funding agreement, whether or not costs of performing the research and development work are being reimbursed under any agreement.

Small Business: Small businesses are domestically incorporated entities that meet the criteria established by the U.S. Small Business Administration's (SBA) "Table of Small Business Size Standards Matched to North American Industry Classification System Codes" (NAICS) (<http://www.sba.gov/content/small-business-size-standards>).

Standalone Applicant: An Applicant that applies for funding on its own, not as part of a Project Team.

Subject Invention: Any invention conceived or first actually reduced to practice under an ARPA-E funding agreement.

Task: A task is an operation or segment of the work plan that requires both effort and resources. Each task (or sub-task) is connected to the overall objective of the project, via the achievement of a milestone or a deliverable.

Total Project Cost: The sum of the Prime Recipient share and the Federal Government share of total allowable costs. The Federal Government share generally includes costs incurred by GOGOs, FFRDCs, and GOCOs.

TT&O: Technology Transfer and Outreach. (See Section IV.G of the FOA for more information).